



**CITY OF SOUTH PASADENA
MOBILITY AND TRANSPORTATION INFRASTRUCTURE COMMISSION
REGULAR MEETING AGENDA**

**Council Chamber
1424 Mission Street, South Pasadena, CA 91030
April 18, 2023 at 6:30 p.m.**

IN-PERSON

NOTICE ON PUBLIC PARTICIPATION & ACCESSIBILITY

Pursuant to Government Code Section 54953, subdivision (e) (3), meetings of the Mobility and Transportation Infrastructure Commission (MTIC) for Tuesday, April 18, 2023, will be conducted remotely and held by video conference.

The in-person/virtual meetings will maintain transparency and public access while protecting the health and safety of the public. Members of the public have the option to participate in-person or via Zoom using the following link:

Mobility and Transportation Infrastructure Commission

Zoom Meeting Information

Meeting ID: 890 2735 8878

Passcode: 447110

1. Go to the Zoom website, <https://zoom.us/join> and enter the Zoom Meeting information accordingly; or
2. Click on the following unique Zoom meeting link:
<https://us02web.zoom.us/j/89027358878?pwd=Nzg2WjltZD2xIT1gxTjluRThkSG5nUT09>
or
3. You may listen to the meeting by calling: +1-669-900-6833 and entering the Zoom Meeting ID and Passcode when prompted to do so.

For additional Zoom assistance with telephone audio, you may find your local number at:

<https://us02web.zoom.us/u/ky9n7bhtz>

PUBLIC COMMENT AND SUGGESTIONS (*Public Comments are limited to 3 minutes*)

The MTIC welcomes public input. If you would like to comment on this agenda item, members of the public may participate by means of one of the following options:

Option 1: Participants will be able to “raise their hand” using the Zoom icon during the meeting, and they will have their microphone un-muted during the comment portion of the agenda to speak for up to 3 minutes; or

Option 2: Email public comment(s) to: mticpubliccomments@southpasadenaca.gov. **Public Comments received in writing will not be read aloud at the meeting, but will be part of the meeting record.** Written Public Comments will be uploaded online for public viewing under Additional Documents. There is no word limit on emailed Public Comment(s).

Please make sure to indicate: 1) your name (optional), and 2) what agenda item you are submitting public comment on, and/or 3) Submit by no later than 12:00pm., on Tuesday, April 18, 2023.

CALL TO ORDER: Chair Dunlap

ROLL CALL: Commissioners: Commissioner Abelson, Chair Dunlap, Commissioner Fisher, Commissioner Hughes, and Commissioner Zavala.

CITY COUNCIL LIAISON: Councilmember Jack Donovan

STAFF PRESENT: Ted Gerber, Public Works Director (“PWD”) and Leonna DeWitt, Public Works Assistant (“PWA”)

PLEDGE OF ALLEGIANCE: Commissioner Abelson

PUBLIC COMMENT

1. Public Comment – General

INFORMATION REPORTS

2. Project Status Update – PWD Gerber

ACTION / DISCUSSION

3. Evaluation of a Second Crossing Guard on Huntington Drive and Marengo Avenue

4. Approval of Minutes of the Regular Mobility and Transportation Infrastructure Commission Meeting on March 21, 2023

COMMUNICATIONS

5. City Council Liaison Communications

6. Commissioner Communications

7. Staff Liaison Communications

ADJOURNMENT

FUTURE MOBILITY AND TRANSPORTATION INFRASTRUCTURE COMMISSION MEETINGS

April 26, 2023	Special Joint Meeting	6:30 p.m.
May 16, 2023	Council Chamber	6:30 p.m.
June 20, 2023	Council Chamber	6:30 p.m.

PUBLIC ACCESS TO AGENDA DOCUMENTS AND BROADCASTING OF MEETINGS

Commission Meeting agenda packets are available online at the City website: <https://www.southpasadenaca.gov/government/boards-commissions/mobility-and-transportation-infrastructure-commission>

ACCOMMODATIONS



The City of South Pasadena wishes to make all of its public meetings accessible to the public. If special assistance is needed to participate in this meeting, please contact the City Clerk's Division at (626) 403-7230. Upon request, this agenda will be made available in appropriate alternative formats to persons with disabilities. Notification at least 48 hours prior to the meeting will assist staff in assuring that reasonable arrangements can be made to provide accessibility to the meeting (28 CFR 35.102-35.104 ADA Title II).

I declare under penalty of perjury that I posted this notice of agenda on the bulletin board in the courtyard of City Hall at 1414 Mission Street, South Pasadena, CA 91030, and on the City website as required by law.

4/13/2023
Date

Deanna DeWitt
Deanna DeWitt
Public Works Assistant

ITEM 2
Project Status Update



Mobility and Transportation Infrastructure Commission Agenda Report

ITEM NO. 2

DATE: April 18, 2023
FROM: H. Ted Gerber, Director of Public Works
SUBJECT: **Project Status Update**

Recommendation

It is recommended that the Commission receive and file an update on the status of projects related to the City’s mobility and transportation infrastructure.

Information

Public Works projects are generally divided into two areas: (1) Capital Improvement Program (CIP) projects and (2) routine or special Operations & Maintenance (O&M) projects. Ongoing or planned projects related to mobility and transportation infrastructure in both of these areas, along with their recent status, are listed in the tables below.

Capital Improvement Program (CIP) Projects	Project Status
Fair Oaks Traffic Signal Improvements Project	<p><u>No Significant Update</u> <i>Project complete and operational, closeout is underway.</i></p> <p>This project installs fiber optic cable and devices along Fair Oaks, Huntington Drive, and Fremont Avenue, as well as a Traffic Management Center (TMC) at City Hall and Public Works offices at the Garfield Water Distribution Facility (WDF).</p> <p>Project is complete and operational. Staff are awaiting as-built drawings from the contractor. A Notice of Completion will be brought to Council, and staff will request reimbursement from Caltrans. Project to be removed from the list.</p>
Mission and Fremont Rectangular Rapid Flashing Beacons	<p><u>No Significant Update</u> <i>Staff completed invoicing agreement and working to release bid.</i></p> <p>This project installs Rectangular Rapid Flashing Beacons (RRFBs) at Fremont Avenue and Lyndon Street, Mission Street and Diamond Avenue, and Mission Street and Fairview Avenue.</p> <p>Staff completed the process of setting up a Program Supplemental Agreement with Caltrans to initiate invoicing for Preliminary Engineering and Construction. Staff are preparing to release the bid package.</p>

Project Status Update

April 18, 2023

Page 2 of 8

Capital Improvement Program (CIP) Projects	Project Status
Street Improvements	<p><u>Updated Status</u> <i>First Design/Bid Package to be released by June.</i></p> <p>On March 1st, Council approved an On-Call Professional Service Task Order to facilitate the project delivery of multiple street improvement projects and develop a 5-year comprehensive and focused Street Improvement Program. Staff and the consultant are working with the design consultant to finalize designs that will be included in the 2022-2023 solicitation package – which will consist of 2-3 projects. The work will be discussed at the ‘State of Streets’ joint Council & MTIC Meeting on April 26, 2023.</p>
Measure M Project Funding Requests	<p><u>No Significant Update</u> <i>Two Projects Approved.</i></p> <p>Two of the submitted projects were approved (MM5506.06 - Grevelia Street and Fair Oaks Avenue & MM5506.08-Orange Grove Avenue Widening from Oliver Street to Arroyo Seco Park), and staff are working with Metro to file the documents necessary in order to execute funding agreements. Staff will evaluate the actions needed on the other submitted projects.</p>
Columbia Street Striping & Signal Improvements	<p><u>Updated Status</u> <i>\$9.9M in Measure R Mobility Improvement Project (MIP) Funds were approved by Metro, however the project will need to be revisited.</i></p> <p>On April 12, 2023 the City of Pasadena’s Planning Commission determined Pasadena’s funded project to not be consistent with the City General Plan. City staff will work with Pasadena DOT to determine the next steps to move this project forward..</p>
Fremont/Huntington Mobility Active Transportation Project	<p><u>No Significant Update</u> <i>Feasibility and charrette contract being developed.</i></p> <p>Staff worked with a consultant to develop a scope that includes feasibility work and public feedback sessions through a charrette process. Development of a proposed contract is underway.</p>
City of Pasadena ‘Stub’ Relinquishment & Transitional Project Development	<p><u>No Significant Update</u> <i>Awaiting Metro Board review.</i></p> <p>Pasadena submitted this long-term project to Metro for Measure R Mobility Improvement Project (MIP), and funding approval is pending review as it was separated from the larger MIP funding request that was approved in February 2023.</p>

Project Status Update

April 18, 2023

Page 3 of 8

Capital Improvement Program (CIP) Projects	Project Status
Sidewalks Replacement & ADA Ramps Upgrades	<p><u>No Significant Update</u> <i>Bid Package in development.</i></p> <p>Staff are developing the bid package for multiple curb ramp replacements along Meridian Avenue. Staff met with the Los Angeles County Development Authority Community Development Division to discuss the project progress and funding deadlines. The bid package requires review by a labor compliance specialist and several non-standard ramp locations require input from a design consultant. Once these reviews are complete, the package will be released for bidding.</p>
North-South Corridor Intelligent Transportation Systems (ITS) Deployment Project	<p><u>Updated Status</u> <i>Public Outreach Meeting Scheduled.</i></p> <p>A public outreach meeting for this project will be held on May 18, 2023 at the Library Community Room. Staff and the consultant will hold the next project status meeting with the Federal Highway Administration and Caltrans in late April, to discuss progress on the Environmental Study.</p>
Farmer's Market Bollard System	<p><u>No Significant Update</u> <i>Pending grant research.</i></p> <p>This future proposed project is listed in the 5-Year Capital Improvement Program (CIP) approved by City Council on June 1 2022. The project is scheduled for implementation in Fiscal Year 2023-2024. Staff will explore funding this project through a pedestrian improvement grant.</p>
Fair Oaks SR-110 Interchange Loop/Hook On-Ramp	<p><u>No Significant Update</u> <i>Alternative study scope being developed for City Council approval.</i></p> <p>A task order to prepare initial study documents is being developed with a professional services on-call consultant for City Council approval. After Council approval, the consultant and City staff will coordinate a meeting with Metro and Caltrans to discuss near-term study work and future Measure R Mobility Improvement Project (MIP) funding. Staff will be presented an overview of these next steps during the March 21, 2023 MTIC meeting.</p>
Fair Oaks SR-110 Interchange Loop/Hook Grevelia Off-Ramp	<p><u>No Significant Update</u> <i>Alternative study scope being developed.</i></p> <p>See above "Fair Oaks SR-110 Interchange Loop/Hook On-Ramp" status.</p>

Project Status Update

April 18, 2023

Page 4 of 8

Capital Improvement Program (CIP) Projects	Project Status
<p>Highway Safety Improvement Program (HSIP) Cycle 11 Projects</p>	<p><u>New Project</u> <i>Recently awarded grant funding.</i></p> <p>On March 9, 2023, South Pasadena was awarded over \$500,000 in HSIP funding for four (4) projects submitted in Fall 2022 related to street lighting, bike lanes, and pedestrian crossing improvements at multiple locations.</p>

Operations & Maintenance (O&M) Projects	Project Status
<p>2022-2023 Slow Streets & Open Streets Program</p>	<p><u>Updated Status</u> <i>Residential designs to be presented.</i></p> <p>Work on the Mission Street design is commencing with a review of the 2021 traffic study. A review of the residential street section is planned for the May 16, 2023 MTIC Meeting.</p>
<p>Neighborhood Traffic Management Program (NTMP) Implementation</p>	<p><u>No Significant Update</u> <i>Pending staff requirements development.</i></p> <p>Staff are developing the requirements to implement a NTMP processing system, including an online/app form, community user guide, and a report output for staff. The system will be integrated into the City's app request system and/or service request system. In the meantime, staff continue to receive and process requests from the community related to neighborhood traffic management.</p>
<p>Ramona Avenue, Oak Street, Rollin Street, & Fremont Avenue Traffic Management</p>	<p><u>No Significant Update</u> <i>Student/Parent outreach planned.</i></p> <p>City staff met with local residents and received many comments about the planned implementation. Thereafter, City staff discussed the improvements at the South Pasadena Unified School District/City Ad Hoc Committee Meeting in late February 2023. City staff will be providing the School District outreach material for distribution to parents/students.</p>

Project Status Update

April 18, 2023

Page 5 of 8

Operations & Maintenance (O&M) Projects	Project Status
<p>Meridian Avenue Traffic Management & Safety Measures</p>	<p><u>No Significant Update</u> <i>Pending task order issuance.</i></p> <p>Staff have evaluated the site conditions and traffic data to discuss potential improvements to Meridian Avenue. This information was presented at the July 2022 MTIC meeting, and the Commission provided feedback. A study will be conducted, including a speed survey, which will be coordinated with local stakeholders. A task order is being issued to a professional services on-call consultant for this work. Recently, the pedestrian crossing at Meridian and Bank has been refreshed with new paint and a new sign. The nearby City trees have been trimmed and residents have been notified by mail to trim nearby privately owned overgrown trees.</p>
<p>Timing Improvements at the Metro Gold Line Mission & Meridian</p>	<p><u>No Significant Update</u> <i>Task order being executed.</i></p> <p>Staff previously met with MTIC’s Chair to review recommendations regarding the timing of signal lights and railway crossing gates at Mission and Meridian. Metro has provided a contact for timing issues to work with the City. A task order to update the timing sheets for this location is being issued to a professional services on-call consultant. The task order work will also reconcile the City’s previously requested preemption changes with the known timing issues.</p>
<p>Timing Improvements at Orange Grove & Monterey Signal</p>	<p><u>Updated Status</u> <i>Work underway.</i></p> <p>Traffic counts were collected in January. Staff are working to provide documents needed to make making adjustments to the signal timing and prepare updated signal timing sheets.</p>
<p>Timing Improvements at Mission & Garfield</p>	<p><u>Updated Status</u> <i>Work underway.</i></p> <p>Please see the above update for “Timing Improvements at Orange Grove & Monterey Signal” – both projects are at the same stage.</p>

Project Status Update

April 18, 2023

Page 6 of 8

Operations & Maintenance (O&M) Projects	Project Status
<p>Fremont Avenue Southbound Left Turn Pocket South of Huntington Drive Intersection</p>	<p><u>No Significant Update</u> <i>Work scope being developed.</i></p> <p>A task order to develop a striping plan for this project is being issued to a professional services on-call consultant. The striping plan will remove the 'no left turn' marking and create a left-turn pocket to access business at the Southeast corner of Fremont Avenue and Huntington Drive.</p>
<p>Traffic & Parking Impacts along Glendon Way between El Centro Street and Meridian Avenue</p>	<p><u>No Significant Update</u> <i>Pending staff discussion with the Chamber.</i></p> <p>City Council recently approved a new five-year agreement with the Chamber of Commerce that contains updated language to facilitate review of the Farmer's Market event Parking Management Plan. Public Works will work with the Chamber of Commerce to make adjustments with the goal of improving traffic and parking impacts along Glendon Way.</p>
<p>Replacement of Missing Orange Grove Street Lamps</p>	<p><u>No Significant Update</u> <i>Pending staff cost estimate.</i></p> <p>Staff are developing a cost estimate to replace the Orange Grove Street Lamps, and relocating the lamps away from the street where possible.</p>
<p>Measure R Projects / Early Action Projects (EAP) List</p>	<p><u>No Significant Update</u></p> <p>Measure R Mobility Improvement Projects (MIP) were discussed at the November 2022 MTIC Meeting, where some elements of the "SR 710 Early Action Projects (EAP)" are planned to be addressed in the North-South Corridor Intelligent Transportation Systems Project, and the current Measure R programmed projects include the Fair Oaks SR-110 Interchange Loop/Hook On-Ramp and Off-Ramp projects and the Fremont/Huntington Mobility Active Transportation Project (see above items). This item will be changed to "Early Action Projects (EAP) List". EAPs do not have committed funding and will be kept on this list for future tracking.</p>
<p>Installation of City Limit Signs at Various Locations</p>	<p><u>No Significant Update</u> <i>Pending task order issuance.</i></p> <p>A task order to develop a conceptual plan for this project is being issued to a professional services on-call consultant.</p>

Operations & Maintenance (O&M) Projects	Project Status
<p>Preferential Parking Policy</p>	<p><u>No Significant Update</u> <i>Pending General Plan Update.</i></p> <p>As a City Council Strategic Plan goal, Staff will work with Community Development in this area, considering recommendations provided by MTIC. Work will commence after the General Plan and Downtown Specific Plan are completed.</p>
<p>2023 626 Golden Streets Arroyo Fest</p>	<p><u>No Significant Update</u> <i>Under Caltrans Review.</i></p> <p>San Gabriel Valley Council of Governments (SGVCOG) is in the planning stages for this event. In February, the Los Angeles City Council adopted a Resolution lending support to the Caltrans Encroachment Permit Application. Functional reviews of the permit are complete, and the Certificate of Liability Insurance is under legal review. The event is tentatively scheduled to the last Sunday in October 2023 (10/29/23) – 21 days after cicLAvia's annual Heart of LA open streets event.</p>
<p>Traffic Impact Analyses</p>	<p><u>Updated Status</u> <i>Proposed development project initiation.</i></p> <p>Staff met with the developer team and a traffic study consultant to discuss a traffic evaluation for a proposed project southwest of Fair Oaks and Grevelia.</p>
<p>Huntington Drive at Marengo Avenue Crossing Guard Evaluation</p>	<p><u>Updated Status</u> <i>April 18, 2023 MTIC Review.</i></p> <p>A consultant conducted vehicle and pedestrian counts and field observations, and provided draft recommendations to staff. The evaluation will be discussed at this April 18, 2023 MTIC Meeting.</p>
<p>Marengo Avenue Traffic Safety Assessment</p>	<p><u>No Significant Update</u> <i>Task order being brought to City Council.</i></p> <p>Staff revised the scope for the comprehensive traffic safety review along the Marengo Avenue corridor based on feedback from MTIC and residents who submitted comments. The consultant provided a revised scope and fee that includes traffic counts, speed data, and stop compliance surveys at additional locations, as well as an evaluation of traffic island diverters, and an evaluation of the intersection at Alhambra Road. The Task Order is being brought to City Council for approval.</p>

Operations & Maintenance (O&M) Projects	Project Status
Huntington Drive 2000 Block Review	<p><u>New Project</u> <i>To be agenized at a future MTIC Meeting.</i></p> <p>On March 13, 2023, the Public Safety Commission requested that a review of the street configuration at the 200 Block of Huntington Drive be agenized by MTIC after a recent traffic collision. A meeting was held with community members, the City Manager’s office, Public Works, and the Police Department on April 2023 to discuss the resident concerns.</p>
Diamond Avenue Improvements	<p><u>New Project</u> <i>Review of community suggestions and enforcement.</i></p> <p>Staff are reviewing improvements suggested by community members along Diamond Avenue between Mission Street and El Centro. The Police Department has been enforcing parking restrictions and Public Works refreshed the existing red curb paint along the roadway.</p>

Public Notification of Agenda Item

The public was made aware that this item was to be considered this evening by virtue of its inclusion on the legally publicly noticed agenda, and posting of the same agenda and reports on the City’s website.

ITEM 3

Evaluation of a Second Crossing Guard on Huntington Drive and Marengo Avenue



Mobility and Transportation Infrastructure Commission Agenda Report

ITEM NO. 3

DATE: April 18, 2023
FROM: H. Ted Gerber, Director of Public Works
David Peña, Transportation Program Manager
SUBJECT: **Evaluation of a Second Crossing Guard for Huntington Drive
and Marengo Avenue**

Recommendation

Staff proposes that the Mobility and Transportation Infrastructure Commission (MTIC) consider the draft report provided by the City's consultant Minagar & Associates, Inc. (M&A) and provide input and recommendations to staff related to the draft findings, and further recommendation to Council on next actions.

Background

On July 27, 2022, the City Council held a Special Meeting to review residents' request for a second crossing guard at the intersection of Huntington Drive and Marengo Avenue for the 2022-2023 Marengo Elementary School year. The City Council received numerous comments and feedback from the public in support of the second crossing guard, so Council decided to temporarily add a second crossing guard for the 2022-23 school year. At the same time, the City Council requested staff evaluate the need to continue utilizing a second crossing guard beyond the current school year. Minagar & Associates, Inc. (Minagar) was utilized to for this work, and several recommendations and alternatives are being presented to address the concerns at the intersection of Huntington Drive and Marengo Avenue.

Analysis & Discussion

In the draft evaluation of the intersection of Huntington Drive and Marengo Avenue, M&A staff identified several reoccurring concerns from residents based on the public comments, such as speed violations between 60 to 80 mph along Huntington Drive which has a 40-mph zone, limited pedestrian visibility due to vehicles parked along Huntington Drive, violation on red lights while turning left from each direction (Marengo Avenue and Huntington Drive) and making right turns without yielding to pedestrians and other concerns.

M&A reviewed the existing conditions and tabulated all collisions in City of South Pasadena from January 1, 2017 to December 31, 2021 using California Highway Patrol's (CHP) Statewide Integrated Traffic Records System (SWITRS) and UC Berkeley's Transportation Injury Mapping System (TIMS) data. The five-year data revealed that out of the 649 collisions citywide, only six (6) collisions occurred near Huntington Drive and Marengo Avenue during school time, but only a total of two (2)

involved a pedestrian or cyclist. The other four (4) collisions involved motorist versus motorist.

Furthermore, M&A performed a vehicle traffic and pedestrian counts on Thursday, September 1, 2022 during the peak hours from 7:00 am to 9:00 am and 2:00 pm to 4:00 pm to account for the school's ingress and egress. The counts revealed that the highest singular corner pedestrian counts occurred in the AM with 54 pedestrians while 23 pedestrians traversed in the PM, a 58 percent decrease. On-site observations also showed how motorists attempted to make a left turn as quickly as possible coming southbound on Marengo Avenue to eastbound Huntington Drive.

To address the core issues such as speeding and pedestrian visibility, M&A recommended 10 different solutions to mitigate speeding and increase pedestrian visibility, which could be integrated individually or collectively at Huntington Drive and Marengo Avenue.

Speed reduction treatments included:

- 1) Prohibiting right turns for vehicles during red lights
- 2) Implementing a protected left-turn signal on Marengo Avenue
- 3) Installing a pedestrian countdown signal head
- 4) Modifying signal timing for Huntington Drive-reduce the duration of the eastbound and westbound green
- 5) Increasing law enforcement presence

Visibility measures included:

- 6) Elimination of the Huntington Drive crosswalk on the west side approach
- 7) Installation of raised crosswalks on Marengo Avenue
- 8) Trimming of landscape in the center medians
- 9) Relocation of the signal controller box on the northeast corner
- 10) Modification of the signal phasing and include a leading pedestrian interval

Overall M&A determined that due to the low pedestrian volumes in the AM and PM peak hours, a second crossing guard is not warranted. Instead, M&A recommended the implementation of the aforementioned treatments individually or in combination to address the core concerns at the subject intersection.

Public Notification of Agenda Item

The public was made aware that this item was to be considered this evening by virtue of its inclusion on the legally publicly noticed agenda, and posting of the same agenda and reports on the City's website.

Attachment

1. Draft Evaluation of a Second Crossing Guard at Huntington Drive and Marengo Avenue by Minagar & Associates, Inc.

Attachment 1

Evaluation of Second Crossing Guard for Huntington Drive
Marengo Avenue



TO#305

Evaluation of Second Crossing Guard for Huntington Drive at Marengo Avenue



PREPARED FOR:



CITY OF SOUTH PASADENA

Public Works Department
1414 Mission Street
South Pasadena, CA 91030

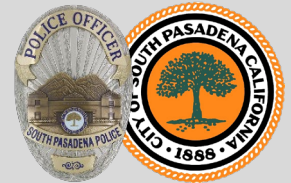

PREPARED BY:



MINAGAR & ASSOCIATES, INC.

ITS - Traffic/Civil/Electrical Engineering - Transportation Planning - Homeland Security - CEM
23282 Mill Creek Drive, Suite 120
Laguna Hills, CA 92653
Tel: (949) 707-1199



29 Years of Excellence

September 6, 2022

DRAFT



EVALUATION OF SECOND CROSSING GUARD FOR HUNTINGTON DRIVE AT MARENGO AVENUE

Prepared for:
CITY OF SOUTH PASADENA

Date:
SEPTEMBER 6, 2022

I, Fred Minagar do hereby certify that this evaluation was performed under my supervision. The enclosed report summarizes the results of a complete and comprehensive evaluation for the need of a second crossing guard at the Huntington Drive and Marengo Avenue intersection in the City of South Pasadena.

The data contained in this report represents a true and accurate evaluation of the existing intersection and its safety risks to pedestrians and bikers within the study area.

Fred Minagar, MS, RCE, PE, Registration No. 53466
Project Manager





TABLE OF CONTENTS

Introduction 3

Existing Conditions..... 5

Data Collection & Analysis..... 6

Field Observations 7

Recommendations 8

Conclusion..... 10

APPENDIX A: SWITRS Collision Data 11

APPENDIX B: Traffic Counts 14





**EVALUATION OF SECOND CROSSING GUARD for
HUNTINGTON DR AT MARENGO AVE
CITY OF SOUTH PASADENA, CA**



Out of eighteen (18) public comments made by parents and students and presented at the City Council Special Meeting on July 27, 2022, six (6) mentioned right turns within the intersection as a primary safety concern, while five (5) comments noted speeding and distracted driving as an issue. Additionally, pedestrian visibility and left turns were also brought up as primary concerns. Violation of red lights, speeding, and drivers' failure to account for pedestrians is the primary concern.

Specifically mentioned concerns include, but are not limited to:

- Speed violations on Huntington Dr up to 60-80 mph despite the speed limit of 40 mph
- Limited visibility of pedestrians waiting on corners due to street parking
- Violation of red lights while turning left from (northbound and/or southbound Marengo Ave to Huntington Dr
- Unprotected left turn phases on Marengo Ave
- Right turns on red from without accounting for pedestrians





Existing Conditions

Existing conditions of the Huntington Dr and Marengo Ave Intersection are shown in the following figure.



Figure 2: Driver Visibility of Huntington Dr & Marengo Ave Crosswalks





Data Collection & Analysis

To better understand the history and conditions of the Huntington Dr and Marengo Ave intersection, collision data from January 1st, 2017, to December 31st, 2021 was collected via the CHP's Statewide Integrated Traffic Records System (SWITRS) and UC Berkeley's Transportation Injury Mapping System (TIMS).

Out of six hundred forty-nine (**649**) collisions occurring in the City of South Pasadena over this period of five years, only six (6) occurred at the subject intersection during school hours, and only two (**2**) of these involved a pedestrian or bicyclist, as shown in the figures below. Detailed collision data regarding the subject intersection can be found in **Appendix A**.

Motor Vehicle Collisions¹ at Huntington Dr & Marengo Ave (2017-2021)

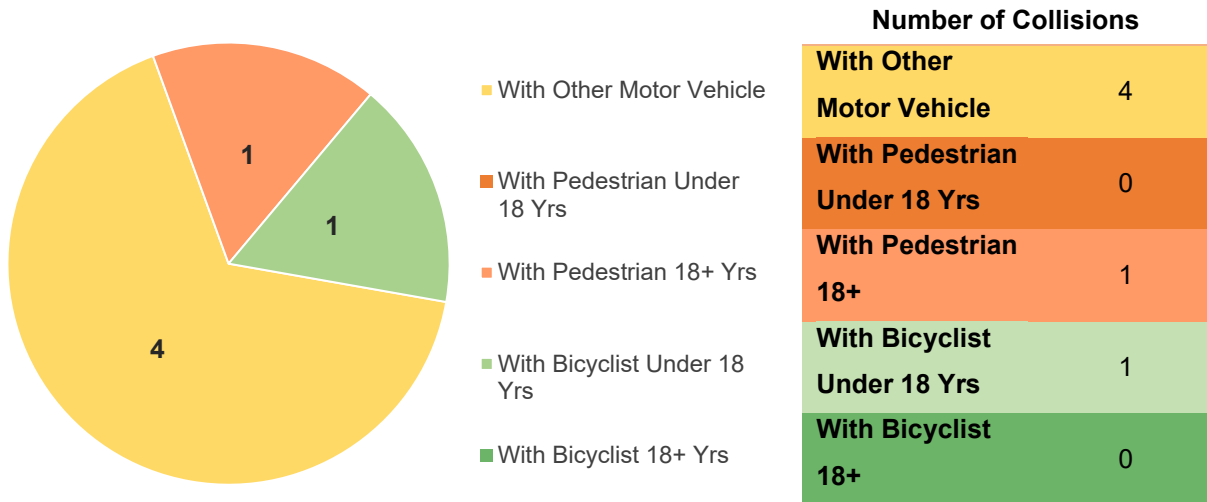

Collisions at Huntington Dr & Marengo Ave by Type² (2017-2021)

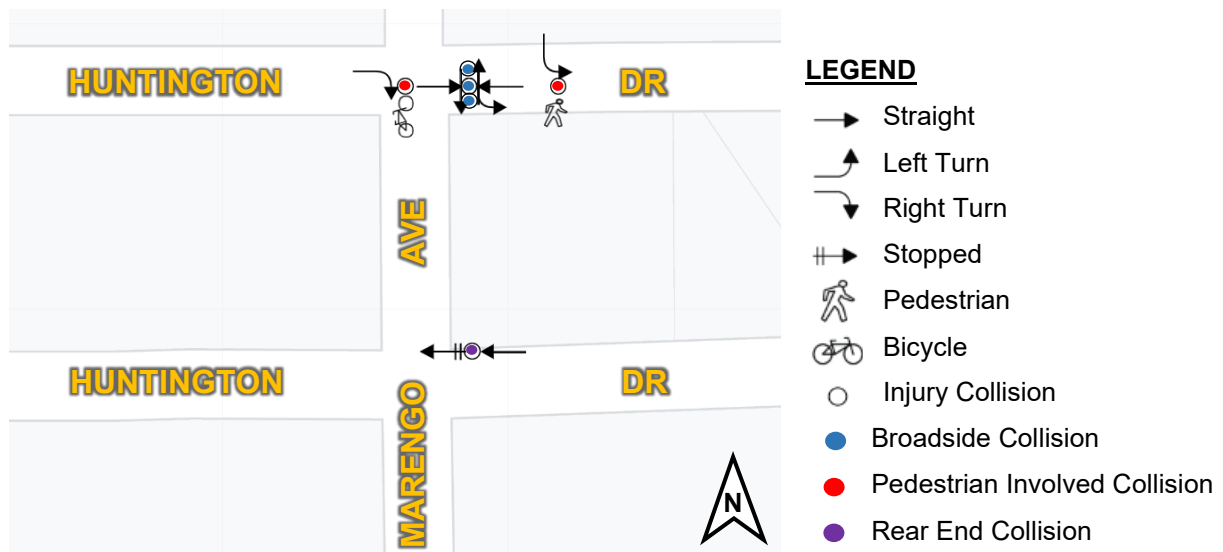

¹ Source: CHP's Statewide Integrated Traffic Records System (SWITRS), January 1, 2017 – December 31, 2021. Collisions shown in the figure account for weekday collisions (Monday through Friday) between the hours of 7:00am to 4:00pm.
² Source: UC Berkeley's Transportation Injury Mapping System (TIMS), January 1, 2017 – December 31, 2021.





Furthermore, to observe traffic flow and pedestrian movement at the subject intersection, Minagar & Associates, Inc. collected traffic and pedestrian counts on the typical weekday of Thursday, September 1st, 2022. Counts were collected from 7:00 to 9:00am and 2:00 to 4:00pm to best represent peak drop-off and pick-up times, based on the daily schedule of Marengo Elementary School shown below. Full traffic counts, including peak hour traffic counts, can be found in **Appendix B**.

Marengo Daily Schedule (Monday-Thursday)

	Start Time	End Time
AM Kindergarten	8:10am	11:35am
PM Kindergarten	11:35am	3:00pm
1 st -2 nd Grade	8:10am	2:25pm
3 rd -5 th Grade	8:10am	2:45pm

Marengo Daily Schedule (Friday)

	Start Time	End Time
AM Kindergarten	8:10am	11:35am
PM Kindergarten	11:35am	3:00pm
1 st -2 nd Grade	8:10am	1:05pm
3 rd -5 th Grade	8:10am	1:15pm

Based on the vehicle and pedestrian counts collected, a singular corner of the intersection is expected to have a maximum of 54 pedestrians during the busiest AM hour. In the afternoon, this decreases to a maximum of 23 pedestrians. With this pedestrian concentration, Minagar & Associates concludes a second crossing guard is not necessary.

Field Observations

As observed on the typical weekday of Thursday, September 1st, 2022, the crossing guard arrived at the intersection at approximately 7:45am to serve students on their way to school. However, students had already begun crossing the intersection since approximately 7:30am. The crossing guard was present at the southeast corner of the intersection and served the crosswalks at the east and south approaches until 8:25am. In the afternoon, the crossing guard was present from approximately 2:05 until 3:15 and sufficiently, effectively and safely served students leaving school.

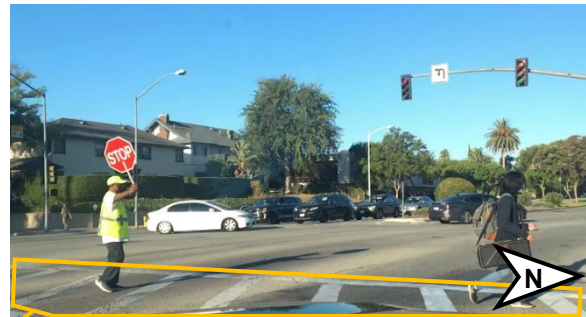

Figure 1: Crossing guard as observed on Thursday, Sept. 1, 2022 serving the crosswalk of the east approach of the subject intersection.





At the east approach, the crossing guard crosses about halfway through the intersection and waits for pedestrians to cross fully before returning back to the southeast corner of the intersection. Occasionally, when pedestrians cross the crosswalk at the west approach, the crossing guard follows parallelly on the east crosswalk to clearly indicate pedestrian presence and display the stop sign for vehicles.

While the crossing guard currently serves the crosswalk at the east and south approaches of the subject intersection, the pedestrian signal head at the southeast corner serving the crosswalk at the east approach, shown in the photo on the right, does not have a pedestrian countdown to display the number of seconds left for pedestrians to cross. Subsequently, southbound vehicles turning left from Marengo Ave to Huntington Dr can get impatient and increase risk to pedestrians who are still crossing even after the “walk” phase ends.

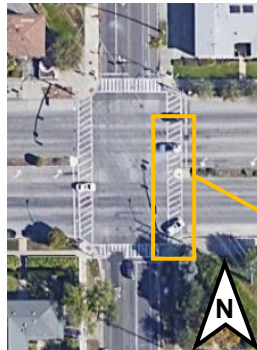

Recommendations

As mentioned previously, concerns specifically mentioned by parents, students, and residents of South Pasadena regarding the subject intersection include, but are not limited to:

- Speed violations on Huntington Dr up to 60-80 mph despite the speed limit of 40 mph
- Limited visibility of pedestrians waiting on corners due to street parking
- Violation of red lights while turning left from (northbound and/or southbound Marengo Ave to Huntington Dr
- Unprotected left turn phases on Marengo Ave
- Right turns on red from without accounting for pedestrians



Subsequent to reviewing the core issues regarding the intersection and considering recommendations from students, residents, and council members, the following are proposed supplemental or alternative solutions to the addition of a second crossing guard.

To reduce risks from speeding and/or turning:



1. **Prohibition of westbound right turns on red** at the northeast corner of the intersection will allow pedestrians to cross Marengo Ave comfortably. This reduces pedestrian risk especially when drivers are entering to drop off or pick up students and are the most rushed and/or distracted.





2. **Implementation of protected left-turn signal phases³ (S07)** at the northbound and southbound left turns of Marengo Ave can reduce pedestrian risk when crossing Huntington Dr. subject to being warranted. This countermeasure reduces potential of all motor vehicle, pedestrian, and bicycle collisions and could be eligible for local funding. 
3. **Installation of pedestrian countdown signal heads⁴ (S17PB)** will allow pedestrians and crossing guards to be aware of how much time they have to cross the intersection before it is the vehicle's right-of-way to turn. This countermeasure reduces pedestrian and bicycle collisions by 25% and is also eligible for local funding. 
4. **Modification of signal phase timing** to shorten the duration of eastbound and westbound thru on Huntington Dr can reduce speeding. With these phases currently lasting a minute or longer, vehicles speeding from a further distance may run red lights rather than slowing down, putting pedestrians on the crosswalks at the east and west approaches at risk. 
5. **Increased police presence** at the intersection during peak commute times according to the bell schedule of Marengo Elementary School can enforce the speed limit and reduce turning violations, thus promoting the safety and comfort of pedestrians.

To increase pedestrian visibility:

6. **Elimination of the Huntington Dr crosswalk** on the west approach to Marengo Ave will increase pedestrian concentration on the east corners of the intersection and increase pedestrian visibility to vehicles while also eliminating the need for a second crossing guard.
7. **Installation of raised crosswalks** on Marengo Ave can increase pedestrian visibility while also encouraging drivers to slow down as they approach the crosswalk. 
8. **Trimming of the plantation** on the median of the west approach to Marengo Ave will increase visibility of pedestrians on the north corners of the intersection. 
9. **Relocation of the signal controller cabinet at the northeast corner** of the intersection can increase pedestrian visibility and prevent accidents as drivers turn right onto Marengo Ave. 
10. **Modification of signal phasing to implement a Leading Pedestrian Interval (LPI)⁵ (S21PB)** provides pedestrians the opportunity to enter an intersection 3-7 seconds before vehicles are

³ Countermeasure No. S07 from the Caltrans Local Roadway Safety Manual, Version 1.6, April 2022.

⁴ Countermeasure No. S17PB from the Caltrans Local Roadway Safety Manual, Version 1.6, April 2022.

⁵ Countermeasure No. S21PB from the Local Roadway Safety Manual, Version 1.6, April 2022.





**EVALUATION OF SECOND CROSSING GUARD for
HUNTINGTON DR AT MARENGO AVE
CITY OF SOUTH PASADENA, CA**



given a green indication. This better establishes pedestrian presence and visibility before vehicles have priority to turn. Since only minor signal timing alteration is required, costs for implementing LPIs are very low.

Conclusion

Based on the existing intersection conditions, current performance of the crossing guard, data collection and analysis, and field observations, Minagar & Associates, Inc. concludes a second crossing guard at the Huntington Dr and Marengo Ave intersection is unnecessary. Pedestrian volumes are currently manageable during the peak AM and PM hours of operations at the subject intersection with one crossing guard. While pedestrian visibility and driver behavior is a valid concern for students and/or parents walking to and from school, these issues can be better resolved by one or a combination of the options described above in the "Recommendations" section rather than a second crossing guard.





APPENDIX A: SWITRS Collision Data





**EVALUATION OF CROSSING GUARD for
HUNTINGTON DRIVE AT MARENGO AVE
CITY OF SOUTH PASADENA, CA**



Weekday Collisions at Huntington Dr & Marengo Ave Intersection (between 7am-5pm)

2017

Primary Rd MARENGO AV	Distance (ft) 48.0	Direction S	Secondary Rd HUNTINGTON DR	NCIC 1970	State Hwy? N	Route	Postmile Prefix	Postmile	Side of Hwy																	
City South Pasadena	County Los Angeles	Population 4	Rpt Dist 1970	Beat 004	Type 0	CalTrans	Badge 205	Collision Date 20170922	Time 1038	Day FRI																
Primary Collision Factor UNSAFE SPEED	Violation 22350	Collision Type REAR END	Severity INJURY	#Killed 0	#Injured 1	Tow Away?	Process Date 20180122																			
Weather1 CLEAR	Weather2	Rdwy Surface DRY	Rdwy Cond1 NO UNUSL CND	Rdwy Cond2	Spec Cond 0																					
Hit and Run	Motor Vehicle Involved With OTHER MV	Lighting DAYLIGHT	Ped Action	Cntrl Dev	FNCTNG	Loc Type	Ramp/Int																			
Party Info																										
Party	Type	Age	Sex	Race	Sobriety1	Sobriety2	Move Pre	Dir	SW Veh	CHP Veh	Make	Year	SP Info	OAF1	Viol	OAF2	Safety Equip	ROLE	Ext Of Inj	AGE	Sex	Seat Pos	Safety	EQUIP	Ejected	
1F	DRVR	24	M	A	HNBD		PROC ST	W	-	0000	KIA	2016	-	3	N	-	M	G								
2	DRVR	34	F	H	HNBD		STOPPED	W	-	0000	CHRY	2007	-	3	N	-	M	G	DRVR	COMP PN 34	F	1	0	M	G	

2018

Primary Rd HUNTINGTON DR	Distance (ft) 15.0	Direction E	Secondary Rd MARENGO AV	NCIC 1970	State Hwy? N	Route	Postmile Prefix	Postmile	Side of Hwy																	
City South Pasadena	County Los Angeles	Population 4	Rpt Dist 4	Beat 004	Type 0	CalTrans	Badge 169	Collision Date 20181219	Time 0800	Day WED																
Primary Collision Factor R-O-W PED	Violation 21950A	Collision Type AUTO/PED	Severity INJURY	#Killed 0	#Injured 1	Tow Away? N	Process Date 20190424																			
Weather1 CLEAR	Weather2	Rdwy Surface DRY	Rdwy Cond1 NO UNUSL CND	Rdwy Cond2	Spec Cond 0																					
Hit and Run	Motor Vehicle Involved With PED	Lighting DAYLIGHT	Ped Action X-WLK AT	Cntrl Dev	FNCTNG	Loc Type	Ramp/Int																			
Party Info																										
Party	Type	Age	Sex	Race	Sobriety1	Sobriety2	Move Pre	Dir	SW Veh	CHP Veh	Make	Year	SP Info	OAF1	Viol	OAF2	Safety Equip	ROLE	Ext Of Inj	AGE	Sex	Seat Pos	Safety	EQUIP	Ejected	
1F	DRVR	45	M	W	HNBD		LFT TURN	S	A	0100	TOYOT	2009	-	3	N	-	M	G								
2	PED	23	M	H	HNBD		PROC ST	N	N	6000	-	-	-	1	F	-	-	PED	COMP PN 23	M	9	1	P	-		

2019

Primary Rd HUNTINGTON DR	Distance (ft) 12.0	Direction W	Secondary Rd MARENGO AV	NCIC 1970	State Hwy? N	Route	Postmile Prefix	Postmile	Side of Hwy																	
City South Pasadena	County Los Angeles	Population 4	Rpt Dist 1970	Beat 004	Type 0	CalTrans	Badge 209	Collision Date 20190527	Time 1048	Day MON																
Primary Collision Factor NOT STATED	Violation 21950A	Collision Type AUTO/PED	Severity INJURY	#Killed 0	#Injured 1	Tow Away? N	Process Date 20191023																			
Weather1 CLEAR	Weather2	Rdwy Surface DRY	Rdwy Cond1 NO UNUSL CND	Rdwy Cond2	Spec Cond 0																					
Hit and Run	Motor Vehicle Involved With BICYCLE	Lighting DAYLIGHT	Ped Action	Cntrl Dev	FNCTNG	Loc Type	Ramp/Int																			
Party Info																										
Party	Type	Age	Sex	Race	Sobriety1	Sobriety2	Move Pre	Dir	SW Veh	CHP Veh	Make	Year	SP Info	OAF1	Viol	OAF2	Safety Equip	ROLE	Ext Of Inj	AGE	Sex	Seat Pos	Safety	EQUIP	Ejected	
1	DRVR	64	M	H	HNBD		RGT TURN	E	-	0000	TOYOT	2004	-	3	-	-	-									
2	BICY	11	F	A	HNBD		PROC ST	N	L	0400	-	-	-	3	A	22107	-	BICY	OTH VIS	11	F	9	3	-	-	

Primary Rd MARENGO AV	Distance (ft) 34.0	Direction N	Secondary Rd HUNTINGTON DR	NCIC 1970	State Hwy? N	Route	Postmile Prefix	Postmile	Side of Hwy																
City South Pasadena	County Los Angeles	Population 4	Rpt Dist 4	Beat 004	Type 0	CalTrans	Badge 216	Collision Date 20190910	Time 1416	Day TUE															
Primary Collision Factor UNSAFE SPEED	Violation 22350	Collision Type REAR END	Severity PDO	#Killed 0	#Injured 0	Tow Away? N	Process Date 20191121																		
Weather1 CLEAR	Weather2	Rdwy Surface DRY	Rdwy Cond1 NO UNUSL CND	Rdwy Cond2	Spec Cond 0																				
Hit and Run	Motor Vehicle Involved With OTHER MV	Lighting DAYLIGHT	Ped Action	Cntrl Dev	FNCTNG	Loc Type	Ramp/Int																		
Party Info																									
Party	Type	Age	Sex	Race	Sobriety1	Sobriety2	Move Pre	Dir	SW Veh	CHP Veh	Make	Year	SP Info	OAF1	Viol	OAF2	Safety Equip	ROLE	Ext Of Inj	AGE	Sex	Seat Pos	Safety	EQUIP	Ejected
1F	DRVR	998	F	H	IMP UNK	IMP UNK	PROC ST	S	-	0000	MERCU	1996	-	3	A	22107	-	B	G						
2	DRVR	38	F	H	HNBD		STOPPED	S	A	0700	TOYOT	2016	-	3	N	-	M	G							



= Pedestrian Involved Collision





**EVALUATION OF CROSSING GUARD for
HUNTINGTON DRIVE AT MARENGO AVE
CITY OF SOUTH PASADENA, CA**



2020

Primary Rd HUNTINGTON DR	Distance (ft) 0.00	Direction	Secondary Rd MARENGO AV	NCIC 1970	State Hwy? N	Route	Postmile Prefix	Postmile	Side of Hwy																
City South Pasadena	County Los Angeles	Population 4	Rpt Dist 4	Beat 004	Type 0	CalTrans	Badge 219	Collision Date 20200514	Time 0714 Day THU																
Primary Collision Factor STOP SGN\SIG	Violation 21453A	Collision Type BROADSIDE	Severity INJURY	#Killed 0	#Injured 3	Tow Away? Y	Process Date 20200811																		
Weather1 CLEAR	Weather2	Rdwy Surface DRY	Rdwy Cond1 LOOSE MATRL	Rdwy Cond2 NO UNUSL CND	Spec Cond 0																				
Hit and Run	Motor Vehicle Involved With OTHER MV	Lighting DAYLIGHT	Ped Action	Cntrl Dev FNCTNG	Loc Type	Ramp/Int																			
Party Info							Victim Info																		
Party	Type	Age	Sex	Race	Sobriety1	Sobriety2	Move Pre	Dir	SW Veh	CHP Veh	Make	Year	SP Info	OAF1	Viol	OAF2	Safety Equip	ROLE	Ext Of Inj	AGE	Sex	Seat Pos	Safety	EQUIP	Ejected
1F	DRVR	57	F	H	HNBD		PROC ST	E	A	0100	-	2015	-	3	N	-	L	G	DRVR	COMP PN 57	F	1	0	L	G
2	DRVR	44	M	H	HNBD		PROC ST	N	A	0100	-	2020	-	3	N	-	L	G	DRVR	COMP PN 44	M	1	0	L	G
																			PASS	COMP PN 23	F	6	0	L	G

2021

Primary Rd HUNTINGTON DR	Distance (ft) 0.00	Direction	Secondary Rd MARENGO AV	NCIC 1970	State Hwy? N	Route	Postmile Prefix	Postmile	Side of Hwy																
City South Pasadena	County Los Angeles	Population 4	Rpt Dist	Beat 004	Type 0	CalTrans	Badge 195	Collision Date 20210126	Time 1003 Day TUE																
Primary Collision Factor UNKNOWN	Violation	Collision Type BROADSIDE	Severity PDO	#Killed 0	#Injured 0	Tow Away? Y	Process Date 20210310																		
Weather1 CLEAR	Weather2	Rdwy Surface DRY	Rdwy Cond1 NO UNUSL CND	Rdwy Cond2	Spec Cond 0																				
Hit and Run	Motor Vehicle Involved With OTHER MV	Lighting DAYLIGHT	Ped Action	Cntrl Dev FNCTNG	Loc Type	Ramp/Int																			
Party Info							Victim Info																		
Party	Type	Age	Sex	Race	Sobriety1	Sobriety2	Move Pre	Dir	SW Veh	CHP Veh	Make	Year	SP Info	OAF1	Viol	OAF2	Safety Equip	ROLE	Ext Of Inj	AGE	Sex	Seat Pos	Safety	EQUIP	Ejected
1	DRVR	62	M	H	HNBD		PROC ST	S	A	0100	-	2004	-	3	N	-	L	G							
2	DRVR	20	F	H	HNBD		PROC ST	E	A	0100	-	2018	-	3	N	-	M	G							





APPENDIX B: Traffic Count Data

(Collected by Minagar & Associates, Inc. on Thursday, Sept. 1, 2022)





Agency Name:
City of South Pasadena

MINAGAR & ASSOCIATES, INC.
23282 Mill Creek Drive, Suite 120
Laguna Hills, CA 92653
Tel: (949) 707-1199

File Name: Huntington Dr
& Marengo Ave
Site Code: 0000001
Start Date: 9/1/2022
Page No: 1

Groups Printed- Unshifted

Start Time	Marengo Ave Southbound					Huntington Dr Westbound					Marengo Ave Northbound					Huntington Dr Eastbound					Int. Total
	Right	Thru	Left	Peds	App. Total	Right	Thru	Left	Peds	App. Total	Right	Thru	Left	Peds	App. Total	Right	Thru	Left	Peds	App. Total	
07:00 AM	6	8	32	3	49	10	86	5	0	101	3	11	3	0	17	0	196	8	0	204	371
07:15 AM	7	10	36	2	55	12	97	2	2	113	3	4	2	1	10	7	222	10	0	239	417
07:30 AM	9	13	49	4	75	9	158	8	2	177	0	10	3	11	24	8	220	11	8	247	523
07:45 AM	2	31	37	4	74	15	199	10	5	229	6	5	12	5	28	23	247	14	20	304	635
Total	24	62	154	13	253	46	540	25	9	620	12	30	20	17	79	38	885	43	28	994	1946
08:00 AM	5	39	35	8	87	16	188	15	8	227	14	22	15	9	60	17	212	20	24	273	647
08:15 AM	4	12	47	14	77	21	259	2	5	287	7	18	10	1	36	4	232	16	2	254	654
08:30 AM	10	17	31	3	61	20	134	2	4	160	4	6	8	4	22	7	241	20	2	270	513
08:45 AM	10	14	22	1	47	17	143	5	1	166	4	9	5	3	21	6	224	18	4	252	486
Total	29	82	135	26	272	74	724	24	18	840	29	55	38	17	139	34	909	74	32	1049	2300
Grand Total	53	144	289	39	525	120	1264	49	27	1460	41	85	58	34	218	72	1794	117	60	2043	4246
Apprch %	10.1	27.4	55	7.4		8.2	86.6	3.4	1.8		18.8	39	26.6	15.6		3.5	87.8	5.7	2.9		
Total %	1.2	3.4	6.8	0.9	12.4	2.8	29.8	1.2	0.6	34.4	1	2	1.4	0.8	5.1	1.7	42.3	2.8	1.4	48.1	

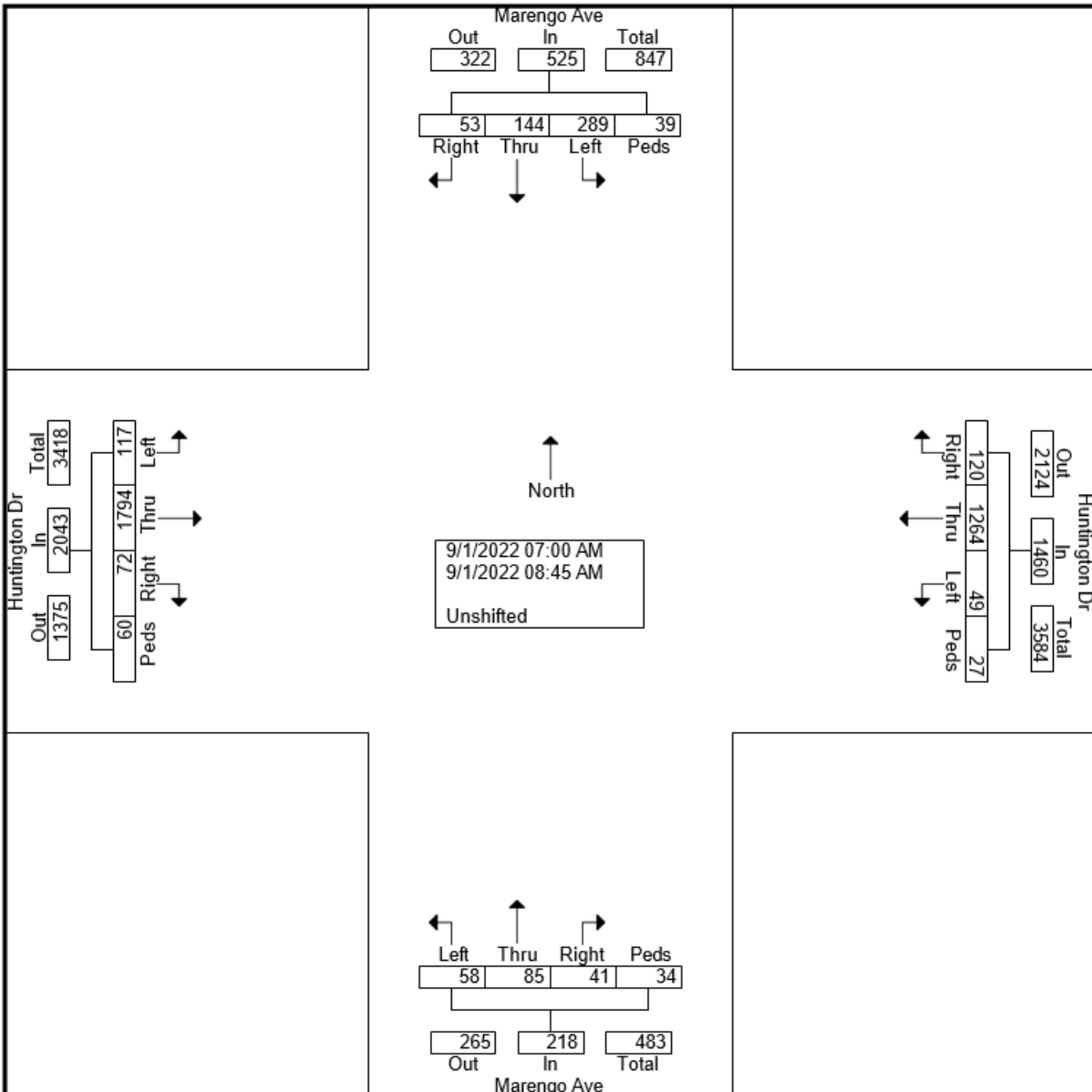

DRAFT



Agency Name:
City of South Pasadena

MINAGAR & ASSOCIATES, INC.

23282 Mill Creek Drive, Suite 120
Laguna Hills, CA 92653
Tel: (949) 707-1199

File Name: Huntington Dr
& Marengo Ave
Site Code: 0000001
Start Date: 9/1/2022
Page No: 2

Start Time	Marengo Ave Southbound					Huntington Dr Westbound					Marengo Ave Northbound					Huntington Dr Eastbound					Int. Total
	Right	Thru	Left	Peds	App. Total	Right	Thru	Left	Peds	App. Total	Right	Thru	Left	Peds	App. Total	Right	Thru	Left	Peds	App. Total	
Peak Hour Analysis From 07:00 AM to 11:45 AM - Peak 1 of 1																					
Peak Hour for Entire Intersection Begins at 07:30 AM																					
07:30 AM	9	13	49	4	75	9	158	8	2	177	0	10	3	11	24	8	220	11	8	247	523
07:45 AM	2	31	37	4	74	15	199	10	5	229	6	5	12	5	28	23	247	14	20	304	635
08:00 AM	5	39	35	8	87	16	188	15	8	227	14	22	15	9	60	17	212	20	24	273	647
08:15 AM	4	12	47	14	77	21	259	2	5	287	7	18	10	1	36	4	232	16	2	254	654
Total Volume	20	95	168	30	313	61	804	35	20	920	27	55	40	26	148	52	911	61	54	1078	2459
% App. Total	6.4	30.4	53.7	9.6		6.6	87.4	3.8	2.2		18.2	37.2	27	17.6		4.8	84.5	5.7	5		
PHF	.556	.609	.857	.536	.899	.726	.776	.583	.625	.801	.482	.625	.667	.591	.617	.565	.922	.763	.563	.887	.940

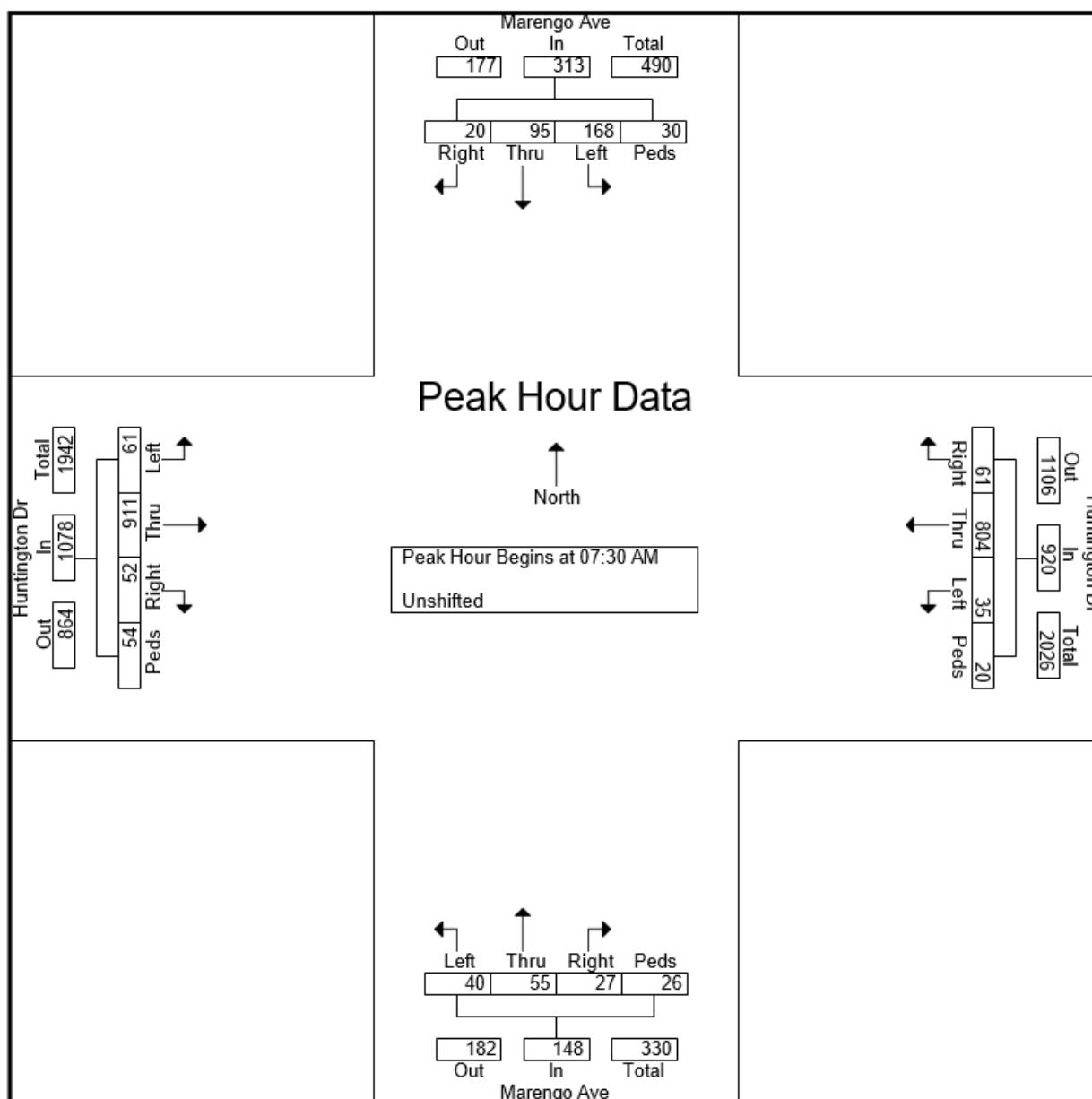

DRAFT



Agency Name:
City of South Pasadena

MINAGAR & ASSOCIATES, INC.

23282 Mill Creek Drive, Suite 120
Laguna Hills, CA 92653
Tel: (949) 707-1199

File Name: Huntington Dr
& Marengo Ave
Site Code: 0000001
Start Date: 9/1/2022
Page No: 3

Groups Printed- Unshifted

Start Time	Marengo Ave Southbound					Huntington Dr Westbound					Marengo Ave Northbound					Huntington Dr Eastbound					Int. Total
	Right	Thru	Left	Peds	App. Total	Right	Thru	Left	Peds	App. Total	Right	Thru	Left	Peds	App. Total	Right	Thru	Left	Peds	App. Total	
02:00 PM	1	7	10	0	18	4	149	22	1	176	8	12	15	0	35	27	178	8	0	213	442
02:15 PM	5	7	4	0	16	11	131	11	0	153	9	17	23	0	49	21	164	12	0	197	415
02:30 PM	7	20	7	2	36	7	150	22	4	183	5	24	30	1	60	25	198	10	2	235	514
02:45 PM	11	23	16	0	50	6	156	20	3	185	5	25	21	15	66	37	246	7	15	305	606
Total	24	57	37	2	120	28	586	75	8	697	27	78	89	16	210	110	786	37	17	950	1977
03:00 PM	6	25	28	0	59	7	159	14	1	181	9	16	18	2	45	34	263	6	8	311	596
03:15 PM	4	17	11	1	33	5	143	23	1	172	6	15	28	3	52	21	273	9	0	303	560
03:30 PM	5	11	5	0	21	2	181	24	0	207	4	11	32	2	49	23	243	4	0	270	547
03:45 PM	1	24	20	1	46	4	141	28	1	174	3	21	32	3	59	43	255	8	0	306	585
Total	16	77	64	2	159	18	624	89	3	734	22	63	110	10	205	121	1034	27	8	1190	2288
Grand Total	40	134	101	4	279	46	1210	164	11	1431	49	141	199	26	415	231	1820	64	25	2140	4265
Apprch %	14.3	48	36.2	1.4		3.2	84.6	11.5	0.8		11.8	34	48	6.3		10.8	85	3	1.2		
Total %	0.9	3.1	2.4	0.1	6.5	1.1	28.4	3.8	0.3	33.6	1.1	3.3	4.7	0.6	9.7	5.4	42.7	1.5	0.6	50.2	

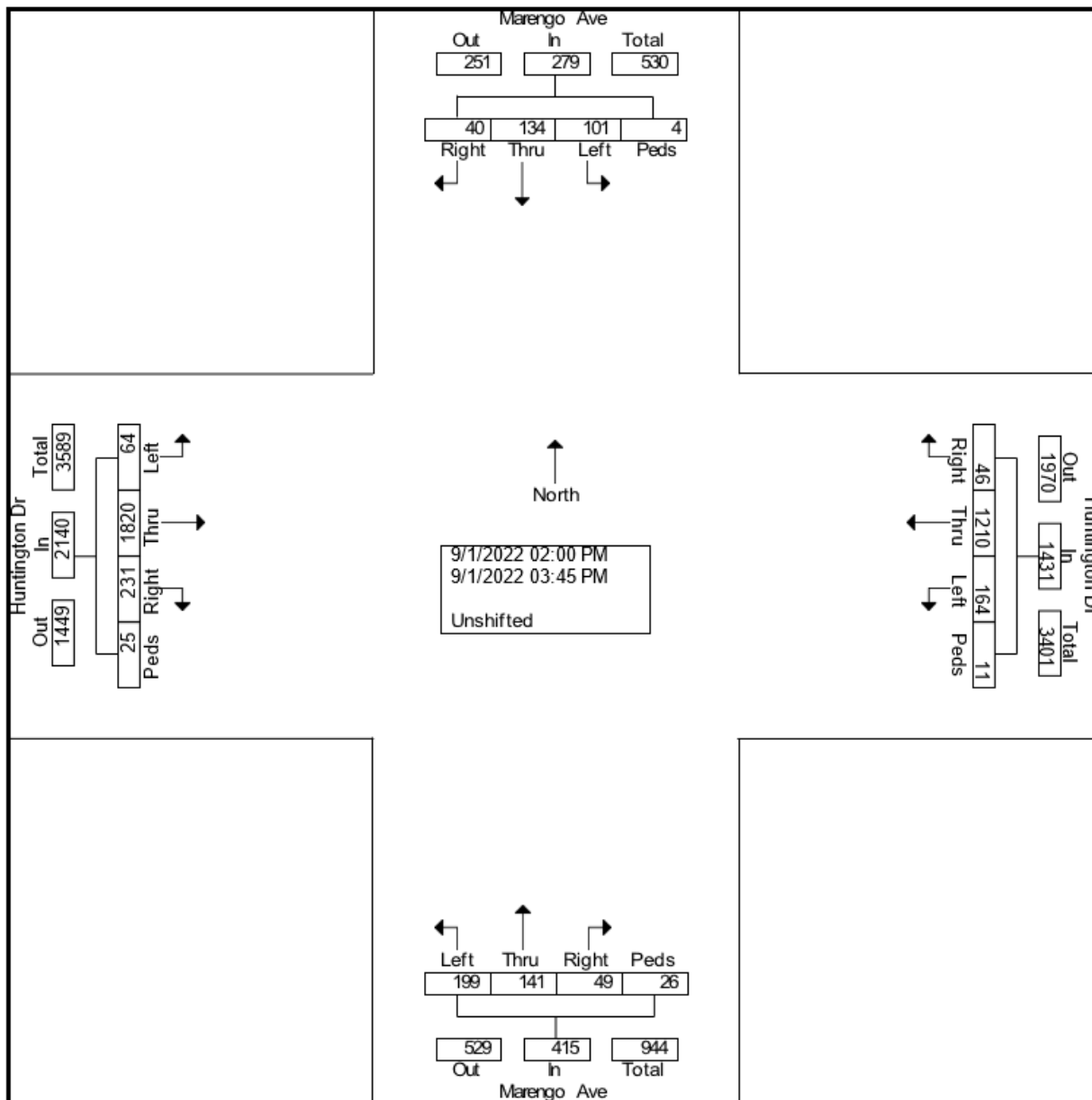

DRAFT



Agency Name:
City of South Pasadena

MINAGAR & ASSOCIATES, INC.

23282 Mill Creek Drive, Suite 120
Laguna Hills, CA 92653
Tel: (949) 707-1199

File Name: Huntington Dr
& Marengo Ave
Site Code: 0000001
Start Date: 9/1/2022
Page No: 4

Start Time	Marengo Ave Southbound					Huntington Dr Westbound					Marengo Ave Northbound					Huntington Dr Eastbound					Int. Total
	Right	Thru	Left	Peds	App. Total	Right	Thru	Left	Peds	App. Total	Right	Thru	Left	Peds	App. Total	Right	Thru	Left	Peds	App. Total	
Peak Hour Analysis From 02:00 PM to 03:45 PM - Peak 1 of 1 Peak																					
Hour for Entire Intersection Begins at 02:45 PM																					
02:45 PM	11	23	16	0	50	6	156	20	3	185	5	25	21	15	66	37	246	7	15	305	606
03:00 PM	6	25	28	0	59	7	159	14	1	181	9	16	18	2	45	34	263	6	8	311	596
03:15 PM	4	17	11	1	33	5	143	23	1	172	6	15	28	3	52	21	273	9	0	303	560
03:30 PM	5	11	5	0	21	2	181	24	0	207	4	11	32	2	49	23	243	4	0	270	547
Total Volume	26	76	60	1	163	20	639	81	5	745	24	67	99	22	212	115	1025	26	23	1189	2309
% App. Total	16	46.6	36.8	0.6		2.7	85.8	10.9	0.7		11.3	31.6	46.7	10.4		9.7	86.2	2.2	1.9		
PHF	.591	.760	.536	.250	.691	.714	.883	.844	.417	.900	.667	.670	.773	.367	.803	.777	.939	.722	.383	.956	.953

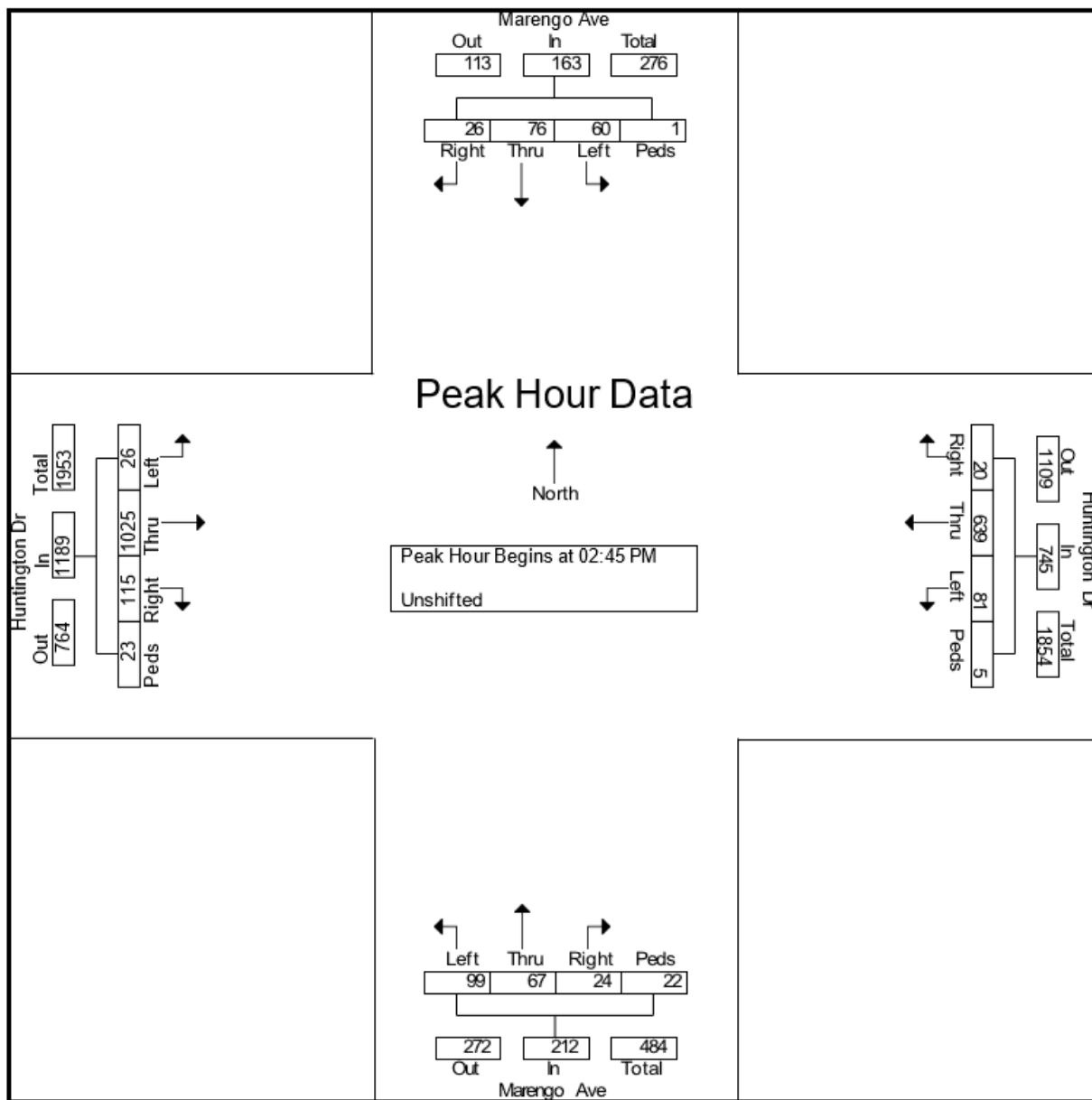



Agency Name:
City of South Pasadena

MINAGAR & ASSOCIATES, INC.

23282 Mill Creek Drive, Suite 120
Laguna Hills, CA 92653
Tel: (949) 707-1199

File Name: Huntington Dr
& Marengo Ave
Site Code: 0000001
Start Date: 9/1/2022
Page No: 5

Huntington Dr & Marengo Ave Intersection



DRAFT



APPENDIX C: Public Comments from City Council Special Meeting





Additional Documents List City Council Special Meeting July 27, 2022

Item No.	Agenda Item Description	Distributor	Document
	Public Comments for Item 1, Item 2 and Item 3	Christina Muñoz, Deputy City Clerk	Attached are public comments.
	Public Comments for Item 2 from the July 20, 2022 Regular City Council Meeting	Christina Muñoz, Deputy City Clerk	Attached are public comments.

**Public Comment
Item #2**

From: [susan sulsky](#)
To: [City Council Public Comment](#)
Subject: Item #2: REVIEW OF RESIDENT REQUEST FOR ADDITION OF A SECOND CROSSING GUARD AT THE INTERSECTION OF HUNTINGTON DRIVE AND MARENGO AVENUE DURING THE 2022-2023 SCHOOL YEAR
Date: Monday, July 25, 2022 5:58:54 PM

CAUTION: This email originated from outside of the City of South Pasadena. Do not click links or open attachments unless you recognize the sender and know the content is safe.

I am in favor of a second crossing Guard at the Intersection of Huntington Drive and Marengo Avenue during 2022-2023 School Year. I was the cross guard at this location for a number of years. Cars disregard the fact that there are children attempting to cross Huntington Drive, and proceed to turn right into the children on both sides of the street. Often they are parents trying to drop their children off, and turn onto Marengo with callous disregard for those walking. One guard is not enough to hold back the cars. The Middle School in San Marino has two guards at the Huntington Drive cross street, which is also a four lane street. If the Council had acted on a previous suggestion to post "No right turn on red during peak crossing hours", it would have been a cost-effective way to handle the situation. They chose once again not to act. Therefore, I see no other solution than to add an additional crossing guard.

Susan Sulsky
2013 Meridian Avenue

Sent from [Mail](#) for Windows

DRAFT

From: [Ella Hushagen](#)
To: [City Council Public Comment](#)
Cc: [Diana Mahmud](#); [ezneimer](#); [Michael Cacciotti - Personal](#); [Jack Donovan](#); [Jon Primuth](#)
Subject: Public comment agenda item 2
Date: Wednesday, July 27, 2022 11:20:20 AM

CAUTION: This email originated from outside of the City of South Pasadena. Do not click links or open attachments unless you recognize the sender and know the content is safe.

Dear City Councilmembers,

In order to meet the community's request for a second crossing guard at Huntington and Marengo, the City will have to increase the contract for crossing guard services by \$19,570.

Please consider that this is less than:

- the City's purchasing authority without City Council approval;
- one day of SPPD's operations in FY 2022-2023 ($\$10,684,973 / 365 = \$29,273$ per day)
- four days of legal services in FY 2022-2023 ($\$2,364,071 / 365 = \$6,476.90$ per day)
- the one-year lease of 12 copiers that was on last week's consent calendar.

Installation of a second crossing guard at the busy intersection will make kids and parents safer when they walk to and from school -- undoubtedly, a worthwhile expenditure that comports with the City's goals of promoting community, safe streets, alternative forms of transportation, and carbon neutrality.

Commissioning a traffic study and creating a citywide crossing guard policy are great ideas. But, please add a crossing guard in the meantime. **Do not make students and parents risk their lives for another school year** while undertaking these measures.

Thank you.

Ella Hushagen

DRAFT

From: [tony fong](#)
To: [City Council Public Comment](#)
Subject: Public Comment
Date: Wednesday, July 20, 2022 12:04:54 PM

CAUTION: This email originated from outside of the City of South Pasadena. Do not click links or open attachments unless you recognize the sender and know the content is safe.

Hello,

My name is Tony Fong and the homeowner of 1934 Marengo. Adding a second crossing guard on Marengo and Huntington makes sense for the safety of the children and pedestrians. It is a busy intersection and there are a lot of walking transactions.

Thank you for your time.

Tony Fong

DRAFT

From: [Sandy Shannon](#)
To: [City Council Public Comment](#)
Subject: Additional Crossing Guard on Huntington & Marengo
Date: Tuesday, July 19, 2022 11:29:33 AM

CAUTION: This email originated from outside of the City of South Pasadena. Do not click links or open attachments unless you recognize the sender and know the content is safe.

Hello,

My name is Sandy Shannon and I am a resident on La France Avenue. Every weekday I walk my 8 year-old and 5 year-old to school, and we cross Huntington Avenue. I have seen countless times cars turning left from Marengo while someone is in the crosswalk. This year someone was turning right from Huntington onto Marengo and almost hit my children. Thankfully I was there to pull them back, but they had the right of way with the cross signal, and this incident could have ended very badly. I also volunteered as the crossing guard a few mornings at the end of the school year, and witnessed many drivers not following the traffic laws.

I am in a fortunate position that I work from home and therefore am able to walk my children to school each day. However, many children walk themselves to school in the morning, and don't have that extra set of parental eyes keeping a watch on all the cars in the area. Huntington Avenue is a major corridor to the LA area, particularly Downtown Los Angeles. People are rushing to work in the morning, and this puts our youngest South Pasadena residents at risk.

We moved to South Pasadena because of the strong community and excellent public education system, and safety when walking to school is a basic tenet of those values. Please add the second crossing guard at Marengo & Huntington, before an accident happens that could have been so easily prevented.

Thank you for your time and consideration on this important matter.

Sincerely,
Sandy Shannon

DRAFT

From: [Cassie Terhune](#)
To: [City Council Public Comment](#)
Subject: Crossing Guard at Marengo & Huntington - Agenda Item 29 for Wednesday 7/20/2022
Date: Tuesday, July 19, 2022 4:52:35 PM

CAUTION: This email originated from outside of the City of South Pasadena. Do not click links or open attachments unless you recognize the sender and know the content is safe.

Hello Council Members & fellow South Pasadenans,

We are hoping you will take our need for a second crossing guard at Marengo & Huntington by the first day of the 2022-2023 school year as seriously as we do. We live south of Huntington and our two high schoolers have to cross this intersection to get to school. Our children have experienced too many close calls, and we no longer let them cross there during school rush hour, which is a sad statement about our community and how we care for our students. Cars crossing onto Huntington during the walk light either do not see the pedestrians or do not care. We have witnessed two different neighbors at two different times almost be mowed down, small children and strollers in tow. It is terrifying and ridiculous.

We do not have time to wait for a traffic study. One certainly needs to be done, but we absolutely cannot allow our children and caregivers to be left in the present precarious situation while we wait. There are three public schools whose zone of attendance includes our neighborhood, and that intersection is the safest way we have to cross. We must make the safety of our school children a priority.

Please do not let my friends and our children get hurt or killed while we wait on action to be taken. A second crossing guard is an easy solution, and we need one in place on August 11. Please act for our safety.

Sincerely,
Cassandra & Andrew Terhune

DRAFT

From: [Kristen Kuhlman](#)
To: [City Council Public Comment](#)
Subject: Crossing guard at Marengo/Huntington
Date: Wednesday, July 20, 2022 10:15:46 AM

CAUTION: This email originated from outside of the City of South Pasadena. Do not click links or open attachments unless you recognize the sender and know the content is safe.

My kids and I had yet another close call last month walking to summer school at the intersection of Marengo and Huntington Drive. Many of the drivers making a right turn from Huntington to go south on Marengo don't slow down to look for pedestrians stepping into the crosswalk before they make their turns. Visibility is also very poor at the southwest corner of the intersection as cars are typically parked all along the south side of Huntington. Cars cannot see us standing on the corner waiting to cross.

What would help? A crossing guard standing on that corner wearing a bright yellow vest holding a large stop sign to get drivers' attention before we step into the street. Please consider providing an additional crossing guard to help our kids and parents cross safely on both sides of the street!

Thank you,
Kristen Kuhlman

DRAFT

From: [Ella Hushagen](#)
To: [City Council Public Comment](#)
Subject: Fwd: PSC Public Comment Re: Second Crossing Guard at Marengo & Huntington
Date: Wednesday, July 20, 2022 12:01:46 PM
Attachments: [2022-06-13 comment re crossing guard Marengo and Huntington.pdf](#)

CAUTION: This email originated from outside of the City of South Pasadena. Do not click links or open attachments unless you recognize the sender and know the content is safe.

Hello,

I am submitting this public comment signed by 113 community members, as well as some public comments by children who live south of Huntington, which was previously submitted to the Public Safety Commission. Please include it in the agenda packet for **agenda item 25**.

Thanks!

Ella Hushagen

DRAFT

June 13, 2022

Public Comment Re: Second Crossing Guard at Huntington Dr. and Marengo Ave.

Dear Public Safety Commissioners,

We submit this comment to request a second crossing guard at the intersection of Huntington Drive and Marengo Avenue.

In the past school year, there have been a number of near misses, wherein drivers turning onto Huntington from Marengo have almost hit children and adults. A mom had to aggressively flag down a driver to prevent him from colliding with her 9-year-old kids, on their way to school. A dad had to essentially push his child out of the way of a turning vehicle. On Friday, May 13, 2022, a father heading home from dropping off his kids was nearly struck by a speeding car turning left onto Huntington. The car swerved wildly to avoid striking him.

The intersection serves many Marengo Elementary and South Pasadena Middle and High School students who live south of Huntington. The crossing guard stationed at the southeast corner of the intersection is attentive and reliable. But this is a large, busy intersection, with six lanes of traffic to cross. Commuters treat Huntington like a highway, driving at very high speeds. There are serious risks to student pedestrians and their parents that one crossing guard cannot mitigate alone.

The City's current contract for crossing guard services is \$177,716 per year—less than two percent of the \$10 million South Pasadena Police Department annual budget. The addition of one crossing guard at Marengo and Huntington to promote the safety of our students and pedestrians is reasonable and doable.

At a similar intersection with Huntington near Valentine Elementary in San Marino, the city has stationed two crossing guards.

South Pasadena is a wonderful city for walking, with its tree-lined streets and friendly neighbors. We want to encourage our students to walk by creating a safe environment for it. **We request that you recommend that City Council direct SPPD to station a second crossing guard at Marengo and Huntington.**

Signed,

- | | |
|----------------------------|--------------------|
| 1. William D. Allen, MD | 8. Amy Betts |
| 2. Alexis Altounian | 9. James Boyle |
| 3. Bree Arnall-Hazard | 10. Kristin Boyle |
| 4. Elizabeth Arnall-Hazard | 11. Candice Carter |
| 5. Soo Baek | 12. Laurie Chatham |
| 6. Eva Bana Romero | 13. Francis Cholko |
| 7. Frederic Bana Romero | 14. Frank Chu |

DRAFT

15. Danelle Courtice
16. David Courtice
17. Owen Ellickson
18. David Evans
19. Sally Evans
20. Jessica Fang
21. Bruce Finstead
22. Melissa Finstead
23. David Foster
24. Katie Gallagher
25. Noel Garcia
26. Armi Gatdula
27. Julie Giulioni
28. Sieu Ha
29. Leslie Hanway
30. Elizabeth Hernandez
31. Elizabeth Hong
32. Wallace Huang
33. Ella Hushagen
34. Kyle Imoto
35. Paula Imoto
36. Chris Kan
37. Jeff Kuhlman
38. Kristen Kuhlman
39. Shirley Lac
40. Julius Law
41. Judy Lee
42. Mindy Lee
43. Shannon Lee
44. Tony Lockhart
45. Deborah Louie
46. Irene Miller
47. Leonard Mlodinow
48. Lisa Montano
49. Jill Nemiro
50. James Park
51. Sarah Perez-Silverman
52. Ken Rudman
53. Shari Sakamoto
54. Shannon Scavo
55. Peter Schubin
56. June Scott
57. Edward Seo
58. Mike Shannon
59. Sandy Shannon
60. Peggy Shirreffs
61. Michael Siegel
62. David Sifuentes
63. Joyce Subject
64. Priscilla Swantner
65. Quinton Swantner
66. Andrew Terhune
67. Cassandra Terhune
68. Vanessa Valencia
69. Lulu Wang
70. Patrick Wright
71. Changhuei Yang
72. Alice Yung
73. Jason Zahn

Name	Email (optional for updates)
ALVARO Maldonado <i>and</i>	[REDACTED]
Hung Jennifer	[REDACTED]
Angie Beth Lombardi Castillo	[REDACTED]
ANDREW MACLOAN	[REDACTED]
STEPHANIE MACLEAN	[REDACTED]
Ayumi Nagata	
JIM TRUONG	
MEVIN DEA	
Andrus POVIAS V.	[REDACTED]
Cindy OKITA	[REDACTED]
Heather Blund	[REDACTED]
Michael Keller	[REDACTED]
Hazen Schnell	[REDACTED]
Alex Lu	[REDACTED]
Ai Rong Wei	
Karen Tamis	[REDACTED]
Lida Aletzi	[REDACTED]
RYAN ROBERTS	[REDACTED]
Ines KNO PERSCHKE	[REDACTED]
SCOTT TOSHIMA	[REDACTED]

GMAIL

Name	Email (optional for updates)
Luis Villa	
Tom Li	[REDACTED]
KEVIN CRUST	
ADAM HAVVITS	
Emily T. Porter	[REDACTED]
Tom Tan	[REDACTED]
[REDACTED]	
[REDACTED]	
[REDACTED]	[REDACTED]
Craig Ressinger	[REDACTED]
Edmund Yip	[REDACTED]
JACK WAN	[REDACTED]
Alex L	
James Boyle	
Ann Shah	
Christina Ghaly	
ALEX MONTES	[REDACTED]
KYLE CHRYSAL	
Jennifer Flint	[REDACTED]
Youn Sook Kim	[REDACTED]

My name is Jack, and I am in 5th grade. I would like a second crossing guard at the Huntington / Marengo intersection. People look at their phones all the time, speed, and blow through red lights. This is why another crossing guard would be helpful.

Hi, my name is Claire Kuhlman. I am going to be a fifth grader. I live on La France Ave, so I walk across Huntington every day to get to school. One time I was about to step into the street when a car came zooming around the corner. My mom had to pull me away, so I wouldn't get hit. I would feel much safer if there was a second crossing guard to help me cross the busy streets. Thank you!



I think its inportant to have
a crossing gaurd because if we
dont kids could get run over.

Love,
Finley



Hi I am Tallulah courtice
I am a 4th grader. I
walk to school every day
and I dont feel safe when
I cross the road.
So if you're ok with this
we can get another crossing
guard so we dont get
hit on Marango or Huntington
street. Maybe if it were
safer my parents would let
me walk to school on my
own.

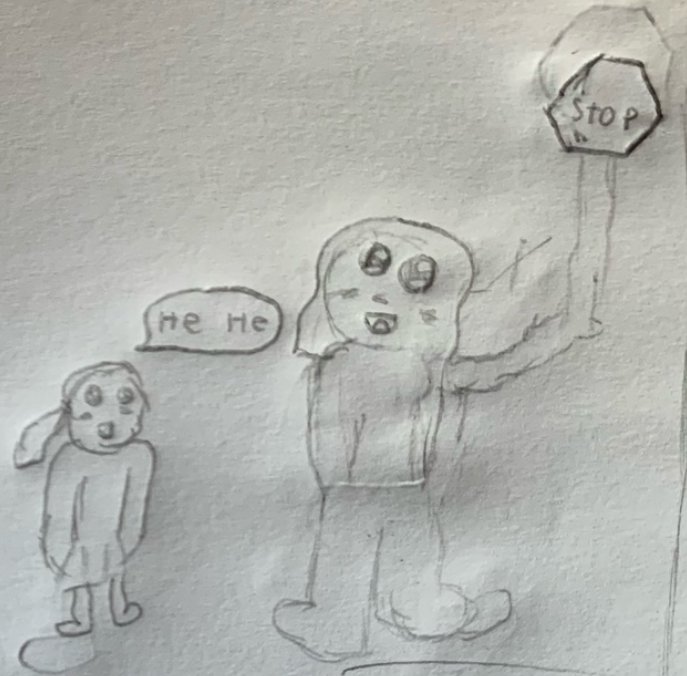

Hi. My name is Lucinda Grace Ellickson. I am a rising 4th grader at Marengo Elementary.

I live on the west side of Marengo, so it's the quickest route for me to get to school. I think it'll be a lot safer once we are promised a second crossing guard for the Marengo and Huntington intersection so that we can stop fretting about getting run over by a truck.

From: [Ji-Lan Zang](#)
To: [City Council Public Comment](#)
Subject: Crossing guard at Huntington and Marengo
Date: Tuesday, July 19, 2022 4:45:12 PM

CAUTION: This email originated from outside of the City of South Pasadena. Do not click links or open attachments unless you recognize the sender and know the content is safe.

Hello,

We are parents of a Marengo Elementary student who cross the Huntington and Marengo crosswalk every day during the school year. We are strongly in support of having a second cross guard at this intersection, as we see many children (some walking, some by bike) who are at danger while crossing the street with vehicles that are turning left and disregard the pedestrian/biker right of way. One crossing guard is simply not enough, as children tend to cross on both the east and west sides of Huntington. The single crossing guard is often stationed at the west side of Huntington, but she is unable to assist the children crossing on the east side of the same street.

Thank you!

Ji-Lan Zang and Wallace Huang, parents of Lucas Huang (Marengo Elementary first grader).

DRAFT

From: [Julie Winkle Giulioni](#)
To: [City Council Public Comment](#)
Cc: [Ella Hushagen](#)
Subject: Let's keep our kids safe!
Date: Tuesday, July 19, 2022 11:06:43 AM

CAUTION: This email originated from outside of the City of South Pasadena. Do not click links or open attachments unless you recognize the sender and know the content is safe.

Please share this as a public comment related to the crossing guard agenda item.

Huntington Drive is a major thoroughfare that carries an ever-increasing volume of traffic that presents a very real danger to local children and parents alike. The configuration of the intersection teamed with the number and speed of vehicles as well as frequently distracted drivers demands more than one crossing guard during peak student transit times. The small incremental increase in expense to the City is insignificant when compared to potential injury or loss of young lives. Let's not force parents to exacerbate traffic and parking problems around Marengo during drop off and pick up. Let's allow kids and families to walk to and from school... and to do it safely. Thank you for your consideration.



Julie Winkle Giulioni
Author, Virtual /Live Keynote Presenter, Inc.'s Top 100 Leadership Speakers

818.219.7988 | www.juliewinklegiulioni.com



From: [BA Finstead](#)
To: [City Council Public Comment](#)
Subject: Marengo and Huntington Drive Intersection
Date: Tuesday, July 19, 2022 12:03:21 PM

CAUTION: This email originated from outside of the City of South Pasadena. Do not click links or open attachments unless you recognize the sender and know the content is safe.

My wife Missy and I have witnessed several “near misses” of cars narrowly missing pedestrians lawfully crossing this intersection. Given the number of unaccompanied grade school children who use this intersection, we believe it is imperative to add an additional crossing guard there. we understand that it would be wise to have a comprehensive approach to the use of crossing guards city wide, but such a need for a general approach should in no way keep the city from adding an additional crossing guard to this intersection immediately.

Bruce “BA” Finstead
Missy Finstead

DRAFT

From: [Paula Imoto](#)
To: [City Council Public Comment](#)
Subject: marengo/huntington crossing guard
Date: Tuesday, July 19, 2022 11:46:58 AM

CAUTION: This email originated from outside of the City of South Pasadena. Do not click links or open attachments unless you recognize the sender and know the content is safe.

Hi... I live south of Huntington and occasionally walk my kids (8 and 6 years olds) to Marengo Elementary School. Over the past two years, I have witnessed many "close calls." Mostly, the drivers are distracted on their phones and/or fail to see pedestrians walking. Some are driving way over the speed limit and cannot stop in time for pedestrians. I have also seen a middle schooler boy walking alone almost being run over by a car that ran a red light. For the safety of our students, families, and pedestrians, it is crucial and essential to add a second crossing guard for this busy intersection before a tragic accident occurs. Thank you for your time and consideration.

Paula Imoto

DRAFT

From: [Edward Seo](#)
To: [City Council Public Comment](#)
Subject: Public Comment - Agenda Item #25 - Request for Crossing Guard
Date: Wednesday, July 20, 2022 11:46:53 AM
Attachments: [SPas Public Hearing Comment 07.20.22 - Crossing Guard - Edward Seo.pdf](#)

CAUTION: This email originated from outside of the City of South Pasadena. Do not click links or open attachments unless you recognize the sender and know the content is safe.

Dear Councilmembers:

My name is Edward Seo, and I am an attorney at the largest law firm in California. I am the managing partner for the Korean Business Litigation Group in the Los Angeles office. I have represented municipalities and various school districts in California, including LAUSD. I have also litigated cases involving traffic control at busy intersections. I am currently an adjunct professor at USC Gould School of Law as well. I make this statement in support of an additional crossing guard at the intersection of Huntington Dr. and Marengo Ave. in South Pasadena (hereinafter referred to as “subject intersection”).

Perhaps more germane than any other family, I own the only single-family home directly at the corner of the subject intersection. I am acutely aware of the traffic accidents that occur mere yards from my property. In fact, a speeding vehicle traveling on Huntington plowed through my property at the corner of Marengo where my kids cross the street to go to school. If not for one of my trees (which is now permanently bowed from the impact), the vehicle would have caused catastrophic damage. This is because of the sheer speed at which these vehicles travel at the subject intersection. Luckily no people were standing at the intersection at the time.

I regularly walk my two children, ages 7 and 8, to Marengo Elementary. In order to do so, we must cross Huntington, a six-lane major road with two additional turning lanes at the stoplight, totaling eight lanes at the intersection. I’m not aware of any other intersections here with that many lanes, with probably the fastest speeds of travel in all of South Pasadena.

Less than two months ago or so, I spoke with a motorcycle police officer at the subject intersection while walking my children to school. I asked him how fast the cars were traveling. The officer told me he tagged someone going in **excess of 80 mph** at the subject intersection during school crossing time. Any pedestrian accident at that speed would result in serious injury or death. Police are aware this speed is the norm rather than an aberration.

The intersection is particularly dangerous not only because of its width and fast speeds, but also because there is no left turn signal from Marengo onto Huntington. Commuters in the morning are in a rush, and oftentimes try to ‘floor it’ on the yield light. Unfortunately, that is the exact time our children need to cross Huntington on Marengo. Many drivers think they

DRAFT

can squeeze by while pedestrians are still crossing on the same side they are turning. This is incredibly dangerous and the precise reason why a second crossing guard is necessary for the health, safety and welfare of our children walking to school. Any traffic control engineer would tell you having a crossing guard would significantly reduce such unsafe turns, as well as right turns on the red light. Construction sites regularly use flaggers for this same reason, and it is proven to reduce accidents and death.

For the foregoing reasons, the city is on notice of the subject intersection, and we respectfully request a crossing guard during the limited school times as it is the most efficient way with the least amount of burden to protect our children. Thank you.

--

Edward W. Seo

From: [Michael Siegel](#)
To: [City Council Public Comment](#)
Subject: public comment - agenda item 29 for 7/20
Date: Tuesday, July 19, 2022 11:16:49 AM

CAUTION: This email originated from outside of the City of South Pasadena. Do not click links or open attachments unless you recognize the sender and know the content is safe.

For Agenda Item 29:

Councilmembers, please vote to use police funds to install a crossing guard at Marengo and Huntington beginning at the start of the school year this August!

Huntington is basically a freeway. Regardless of the speed limit, cars are regularly passing 60mph. As an adult I often feel unsafe crossing Huntington, let alone with small children. For the safety of the community, before someone gets seriously hurt, please vote to install a crossing guard to start the school year.

Thank you for your consideration!

Michael Siegel

DRAFT

From: [Alexis Altounian](#)

To: [City Council Public Comment](#)

Public Comment RE: Agenda Item # 29 on Wednesday

Date: 7/20 Wednesday, July 20, 2022 11:27:13 AM

CAUTION: This email originated from outside of the City of South Pasadena. Do not click links or open attachments unless you recognize the sender and know the content is safe.

Public comment submission:

Hello and good evening City Council Members. I am Alexis Altounian, resident on Marengo Avenue just south of Huntington Drive. I am a lifelong local; now raising my daughter here. While she attends Marengo Elementary, just a few blocks away we often do not walk to school because of so many close calls and accidents that I've witnessed on Huntington Drive over the years. These close calls and accidents have happened more frequently when crossing guards are not present. My father and I would walk and run up Marengo Avenue and witness everything from people running red lights to abrupt turns in front of us in the cross walk as pedestrians.

However, one specific incident I witnessed that I wanted to share occurred in the early 2000s. It was about 3pm on a school day when the crossing guard was struck by a vehicle turning right off of Marengo Avenue onto Huntington Drive who failed to stop and see her. Very fortunately the guard recovered and no children were injured. She happened to be a family friend and I immediately called her son to inform him of the accident and to let him know his mother was being transported to Huntington Hospital.

I understand we can not fix driver behavior but perhaps we can make the cross walk more visible to drivers and safer for pedestrians. I feel that having two crossing guards working in tandem to keep the intersection as safe as possible to and from school would be a significant improvement and beneficial to our community.

Thank you for your time and attention to this matter.

Sincerely,
Alexis Altounian

DRAFT



MINAGAR & ASSOCIATES, INC.

ITS - Traffic/Civil/Electrical Engineering - Transportation Planning - Homeland Security - CEM

	2019 Winner of the Orange County Engineering Council's Outstanding Service Award	
	2016 Winner of the ASCE's Outstanding Civil Engineer in the Private Sector Award in the State of California	
	2016 Winner of the ASCE Los Angeles Section's Outstanding Civil Engineer in the Private Sector Award	
	2016 Winner of the ASCE Orange County Chapter's Outstanding Civil Engineer in the Private Sector Award	
	2016 Certificate of Recognition for Dedication to Support the ELTP Program by Los Angeles County MTA/Metro	
	2016 Winner of the Orange County Engineering Council's Outstanding Engineering Service Award	
	2015 Orange County Business Journal's 2015 Excellence in Entrepreneurship Award Nominee	
	2014 Orange County Business Journal's 2014 Excellence in Entrepreneurship Award Nominee	
	2012 Winner of Cal-EPA/California Air Resources Board's Cool California Climate Leader	
	2011 Award of Excellence in Service by Los Angeles County MTA/Metro in the County of Los Angeles	
	2011 Award of Excellence in Service by Los Angeles County MTA/Metro in the County of Los Angeles	
	2010 Award of Excellence in Service by Los Angeles County MTA/Metro in the County of Los Angeles	
	2009 Winner of the ASCE's Outstanding Private Sector Civil Engineering Project in Metropolitan Los Angeles	
	2009 Winner of the Caltrans' 2009 Excellence in Transportation Award in the State of California	
	2007 Winner of the ASCE's Outstanding Public/Private Sector Civil Engineering Project in Metropolitan Los Angeles	 
	2005 Winner of the APWA's Best Traffic Congestion Mitigation Project of the Year in Southern California	 
	2004 Top Nominee of Transportation Foundation's Highway Management Program in the State of California	
	2003 Winner of the PTI's Best Transportation Technology Solutions Award in the United States	  
	2002 Winner of the ITS-CA's Best Return on Investment Project Award in the State of California	  
	2000 Award of Excellence in Service by Los Angeles County MTA/Metro in the County of Los Angeles	



Celebrating 29 Years of Planning & Engineering Excellence

- **Traffic Engineering**
- **Transportation Planning**
- **ITS (Intelligent Transportation Systems)**
- **Civil/Electrical Engineering**
- **Homeland Security**
- **Construction Engineering Management**

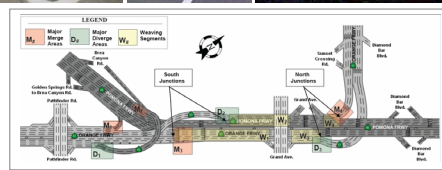

MINAGAR & ASSOCIATES, INC.

23282 Mill Creek Drive, Suite 120
Laguna Hills, CA 92653

Tel: (949)707-1199
Web: www.minagarinc.com



DRAFT

ITEM 4

Approval of Minutes of the Regular Mobility and
Transportation Infrastructure Commission Meeting
on March 21, 2023

TUESDAY, MARCH 21, 2023
MINUTES OF THE CITY OF SOUTH PASADENA
MOBILITY AND TRANSPORTATION INFRASTRUCTURE COMMISSION
REGULAR MEETING

CALL TO ORDER

Chair Fisher called the Regular Meeting of the Mobility and Transportation Infrastructure Commission (MTIC) to order on March 21, 2023, at 6:34 p.m. The meeting was held in-person and virtually via Zoom.

ROLL CALL: Chair John Fisher

Present: Chair Fisher, Commissioner Abelson, Commissioner Hughes, and Commissioner Zavala

Council Liaison: Mayor Jack Donovan

Absent: Vice-Chair Dunlap

Staff Present: Ted Gerber, Public Works Director (“PWD”), (“CEA”), and Leonna DeWitt, Public Works Assistant (“PWA”)

PLEDGE OF ALLEGIANCE

Commissioner Diego led the Pledge of Allegiance.

PUBLIC COMMENT AND SUGGESTIONS

1. Public Comment – General

1. Mary Hoban – She is a resident of Golden Oaks Apartment. She expressed concern regarding entering and exiting the garage is unsafe and is requesting that something be done.
2. Sally Kilby – She is a resident of Golden Oaks Apartment. She expressed concern regarding the entering and exiting the garage is unsafe. Ms. Kilby suggested several ideas for consideration including but not limited to installing a camera at the corner of Mission Street and Diamond Avenue, and active enforcement during Farmers Market to include towing of vehicles.

Via Zoom

3. Anthony Lai – He expressed concern and request prioritizing the installation of curb ramps at several locations in the Monterey Hills in order to comply with applicable state and federal laws. He believes this small improvement can have a significant impact on the safety and accessibility of the community particularly for the disabled and elderly.
4. Erin Fleming – She resides on Huntington Drive. She expressed concern regarding the recent accidents in the area that have breached the curb and sidewalk. Ms. Fleming is requesting safety improvements to protect the residents and pedestrians from this dangerous activity. She requested that this item be agendaized for further discussion.
5. Mr. Kylie – He resides on Huntington Drive. He expressed concern about visibility and high speeds

INFORMATION REPORTS

2. Project Status Update

PWD Gerber highlighted upcoming projects.

3. Planning “State of Streets” Joint Council & MTIC Meeting – April 19th, 2023

PWD Gerber presented the upcoming State of Streets study session with City Council and MTIC which will be held on Wednesday, April 26, 2023 at 6:30p.m. This is an opportunity to share ideas, concerns and prioritization of street projects. The discussion topics will be as follows:

- Pavement Management Program
- Pavement Condition Index Process & Next Iteration
- Street Improvement Projects – Phases and Status
- Transportation Capital Improvement Projects
- Master Planning Effort
- Fund Sources

Discussion ensued regarding striping improvements, cool streets, climate and greenhouse gas reduction, pavement markings, and curb ramps.

Chair Fisher suggested it would be helpful to have a map that includes the improvements over the last six years and then another map showing the streets programmed for the next number of years.

4. Review of Measure R Mobility Improvement Project: Fair Oaks SR-110 Interchange Loop Ramp

PWD Gerber presented a brief overview of this project.

Discussion ensued regarding the project details.

ACTION/DISCUSSION ITEMS

5. Approval of Minutes of the Regular Mobility and Transportation Infrastructure Commission Meeting on January 17, 2023

Minutes approved as amended. Motion made by Commissioner Hughes and seconded by Commissioner Abelson (4-0, motion passes).

6. Selection of Officers

A motion was made by Commissioner Abelson and seconded by Chair Fisher to nominate Commissioner Dunlap as Chair. (4-0 motion passes)

A motion was made by Chair Fisher and seconded by Commissioner Abelson to nominate Commissioner Hughes as Vice-Chair. Commissioner Hughes volunteered to continue to review the minutes. (4-0 motion passes)

COMMUNICATIONS

7. City Council Liaison Communications

Council Liaison Donovan informed the Commission of the first joint session meeting with the Finance Commission to approve the mid-year budget process. He updated the Commission on the Caltrans properties and that the ad hoc committee received the bids back for the remodeling of the unoccupied homes and reviewed the estimates. Council Liaison Donovan stated that they are waiting on Caltrans to notify the city of who will be returning or renting to the homes currently owned by Caltrans. He announced that Little League opened on Friday night with over a thousand people in attendance and his concern is getting rid of the gopher holes at Arroyo Park.

8. Commissioner Communications

Commissioner Hughes thanked staff for the presentation and consolidated report. She requested that staff keep the commission informed regarding the “drop off” with Holy Family. She informed staff that the potholes on the northbound SR-110 Freeway leading to the Orange Grove Avenue off ramp are back due to the rains and if Caltrans can be notified. Commissioner Hughes expressed concern with water conservation and appreciates the continued work by staff.

Commissioner Zavala announced that he received his driver’s license and how that has given him a wider perspective not just as a biker or a pedestrian and gives him an understanding of the habits of drivers, however he would continue to ride his bike.

Chair Fisher suggested for the joint meeting to have snapshots of the large potholes to emphasis if the city doesn’t fund repaving at critical points and the roadway deteriorates very rapidly, but if you catch it before that point the city saves a lot of money. He’s pleased with the South Pasadena sign and how the recent rains and the growth around the letters has framed it nicely.

Commissioner Abelson thanked staff for the presentation and report. He welcomed Councilmember Donovan and congratulated Commissioner Zavala on receiving his driver's license. Commissioner Abelson thanked outgoing Chair Fisher for his leading the meetings, guiding the conversation and working with staff on the agendas. Caltrans repaired a nice impressive segment, which was riddled with holes, but there's another segment further south that needs repair of the Orange Grove Avenue on-ramp southbound. The intersection of State Street and Raymondale has a constantly blinking red traffic signal and if the signals could be repurposed to another location where it could be used.

PWD Gerber stated its difficult to repurpose because the signals are custom design especially as it comes to wind loading.

9. Staff Communications

PWD Gerber stated the City is planning an outreach meeting for the North-South Corridor project and will be held in the Library Community room, the date to be determined. The City has another outreach meeting plan for the stormwater wetland project, to bring cleaner water into the city to use for irrigation. This will be held on Thursday, April 27 at 6:00p.m. at the Library Community room. It's a joint meeting with Pasadena, and our project consultants to answer question and to conduct a walk through. We are targeting to begin construction before the end of this year. The Commission Congress will be held on Wednesday, June 28th. PWD Gerber mentioned the commission will start the discussion of the annual report and work plan for the next fiscal year, which will be agendized on a future meeting.

PWA DeWiitt announced the Annual Dumpster Day Event scheduled for Saturday, April 15, from 8a.m. to 2p.m, on Arroyo Drive, south of Mission Street. For seniors, please contact the Senior Center at 626-403-7360 to register.

ADJOURNMENT: Meeting adjourned at 9:38 p.m.

I HEREBY CERTIFY that the foregoing minutes were adopted by the Mobility and Transportation Infrastructure Commission of the City of South Pasadena at a meeting held on April 18, 2023.

Eric Dunlap, Chair