



---

## **ATTACHMENTS FOR SECTION 2.5:**

### **MONITORING**

---

# **San Gabriel Valley Council of Governments Load Reduction Strategy Projects Preliminary Monitoring Plan for Alhambra Wash**

**Prepared for:**



San Gabriel Valley Council of Governments  
1000 Fremont Ave #42, Alhambra, CA 91803  
TEL (626) 457-1800

**Prepared by:**



1561 E. Orangethorpe Avenue, Suite 240  
Fullerton, California, 92831

TEL (714) 526-7500 | FAX (714) 526-7004 | [www.cwecorp.com](http://www.cwecorp.com)

**October 2020**

# 1. Background

The San Gabriel Valley Council of Governments (SGVCOG), on behalf of the County of Los Angeles (County) and the Cities of Alhambra, Monterey Park, Pasadena, Rosemead, San Gabriel, San Marino, South Pasadena, and Temple City is implementing the Load Reduction Strategy Projects for the Rio Hondo River and Tributaries (Project). The Project was identified in the *Rio Hondo Load Reduction Strategy: Addendum to Revise Implementation Actions for Alhambra Wash, Eaton Wash, and Rubio Wash* (referred to herein as the Rio Hondo LRS) (ULAR EWMP Group, 2017), an addendum to the *Rio Hondo Load Reduction Strategy for the Los Angeles River Watershed Bacteria TMDL* [Total Maximum Daily Load] (ULAR EWMP Group, et al., 2016).

The Project is proposed in response to the National Pollutant Discharge Elimination System (NPDES) Municipal Separate Storm Sewer System (MS4) Permit Order No. R4-2012-0175, which was adopted by the Los Angeles Regional Water Quality Control Board (LARWQCB) and enacted on December 28, 2012. The MS4 Permit identifies the permittees that are responsible for compliance with the MS4 Permit requirements pertaining to the Los Angeles River (LAR) Watershed Bacterial Total Maximum Daily Load (Bacteria TMDL) Resolution No. R10-007. The LAR Bacteria TMDL requires the responsible permittees to meet targets and waste load allocations for the indicator bacterium *E. coli* during wet-weather and dry-weather seasons. The LAR Bacteria TMDL further presents the Load Reduction Strategy (LRS) as a method for achieving compliance and was used to satisfy TMDL requirements.

The Cities of Alhambra, Monterey Park, Pasadena, Rosemead, San Gabriel, San Marino, South Pasadena, and Temple City, along with Unincorporated County have thus entered into an agreement with the SGVCOG to implement the Project to address the LAR Bacteria TMDL, which includes implementation on Alhambra Wash, Eaton Wash, and Rubio Wash.

This Preliminary Monitoring Plan is focused on the low flow diversion proposed on Alhambra Wash, which will address dry-weather bacteria discharges from more than 11,000 acres of tributary area. Seven agencies (Alhambra, Monterey Park, Pasadena, Rosemead, San Gabriel, San Marino, and South Pasadena – referred to as Cities), along with portions of Unincorporated County, contribute to flows that will be captured by the Project. The Cities and Unincorporated County are partnering to implement the Alhambra Wash diversion. **Figure 1-1** below illustrates the Alhambra Wash Project site and associated drainage area.

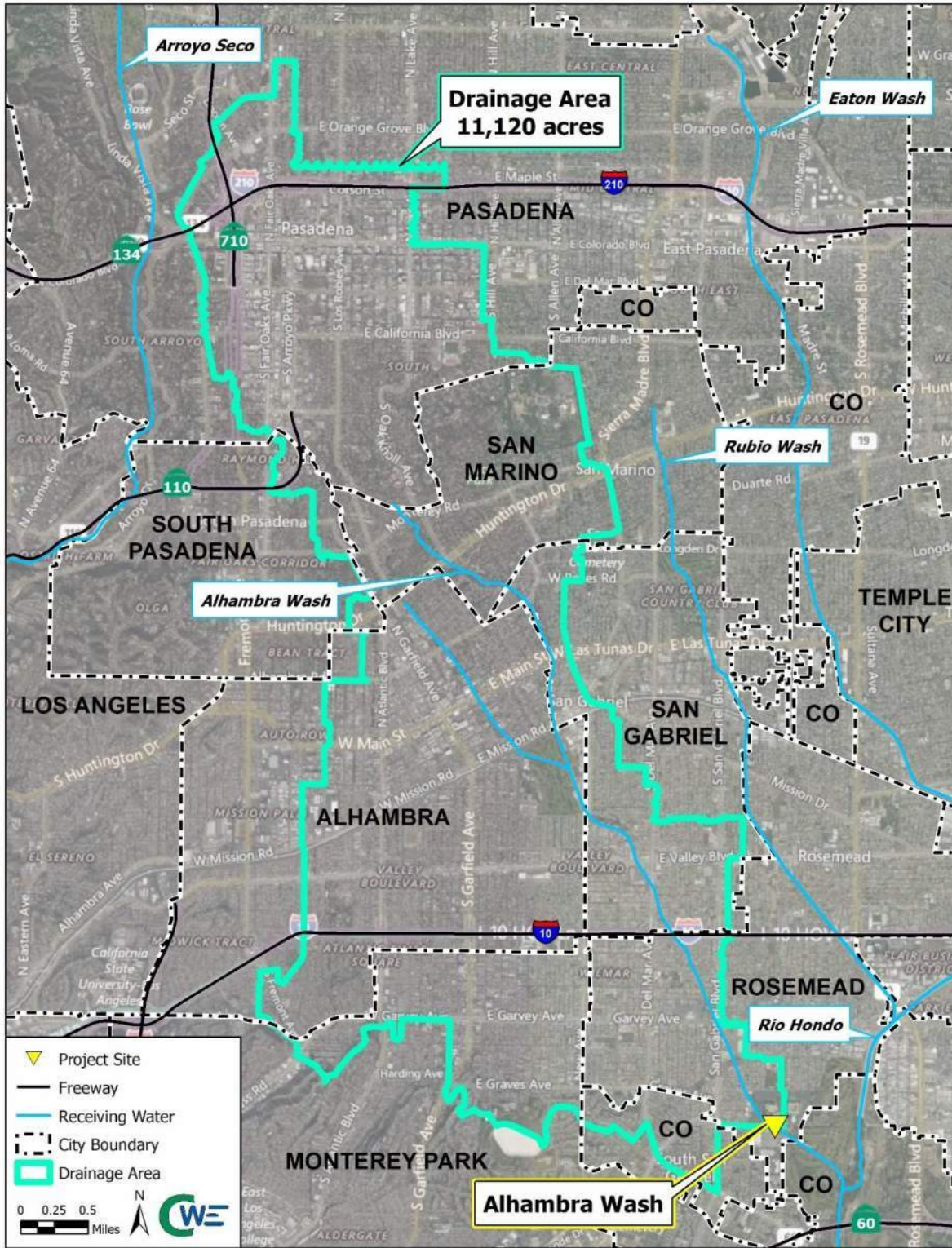
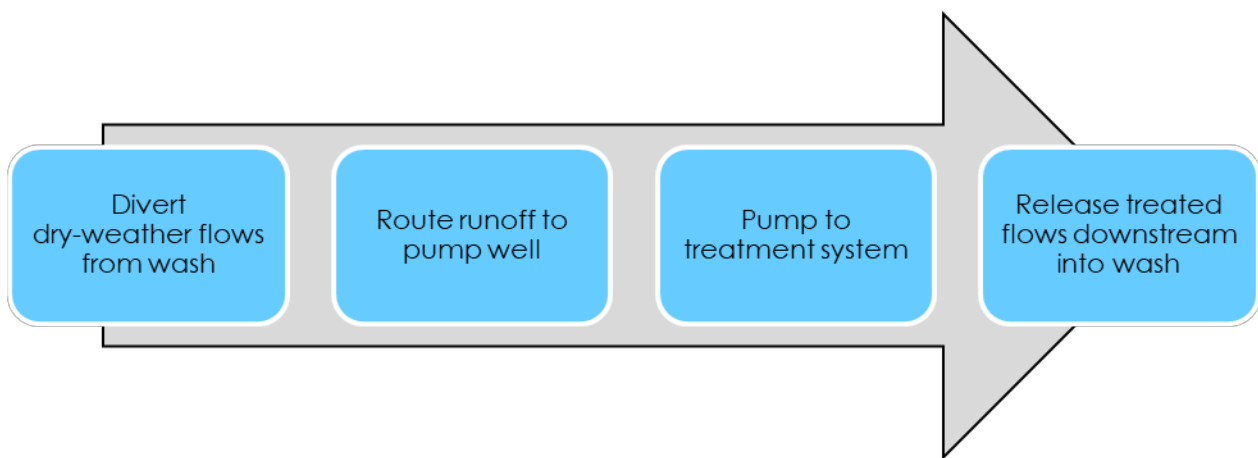

Figure 1-1 Alhambra Wash Drainage Area

## 2. Project Purpose and Goals

The Project is being implemented to meet water quality goals as identified in the Rio Hondo LRS and as required by the MS4 Permit. The Project provides multiple benefits, including water quality enhancements and community benefits. The Project will address dry-weather discharges into Alhambra Wash from the drainage area illustrated in **Figure 1-1**. The original LRS identified a diversion to the sanitary sewer on Alhambra Wash. The LRS alternative, along with several other alternatives, were evaluated as part of a Feasibility Study and it was determined that a treatment system would be most beneficial. **Figure 2-1** illustrates the general concept for the diversion on Alhambra Wash. Flows will be diverted from the channel, pretreated, and pumped to an advanced treatment system before being discharged back into the channel. An Ultraviolet (UV) treatment system is anticipated, which will kill bacteria and address other pollutants.



**Figure 2-1 General Project Concept**

The pump well will be perforated to allow for infiltration to occur, mimicking natural watershed processes. A large-scale infiltration system was not determined to be feasible due to limited available space. Opportunities to implement street trees and a swale are currently under evaluation and may be included. Coordination is ongoing with the local jurisdiction (City of Rosemead). Educational signage will be incorporated to create educational opportunities for the community.

The goals and objectives of the LRS are to reduce bacteria loading to the Rio Hondo, which the selected treatment approach will do. In summary, the Project goals are as follows:

- Enhance water quality locally and in downstream water bodies
- Reduce bacteria loading and contribute towards meeting LAR Bacteria TMDL targets (LRS objective)
- Provide community enhancements, such as street trees and/or swale
- Incorporate educational signage to educate the community

### 3. Proposed Improvements

As mentioned above, several alternatives were evaluated as part of the preparation of the Project Feasibility Study. Proposed improvements are based on the preferred alternative, which includes a channel diversion and advanced UV treatment system. The LRS defined peak discharge capacities at the site that must be addressed to reduce bacteria loading. Peak discharge rates are summarized in gallons per minute (gpm) and cubic feet per second (cfs) in **Table 3-1** below. The anticipated layout of the Alhambra Wash diversion and treatment system are illustrated in **Figure 3-1**.

**Table 3-1 LRS-Defined Peak Discharge Rate**

Site	LRS-Defined Peak Discharge Rate	
	(gpm)	(cfs)
Alhambra Wash	1,000	2.23

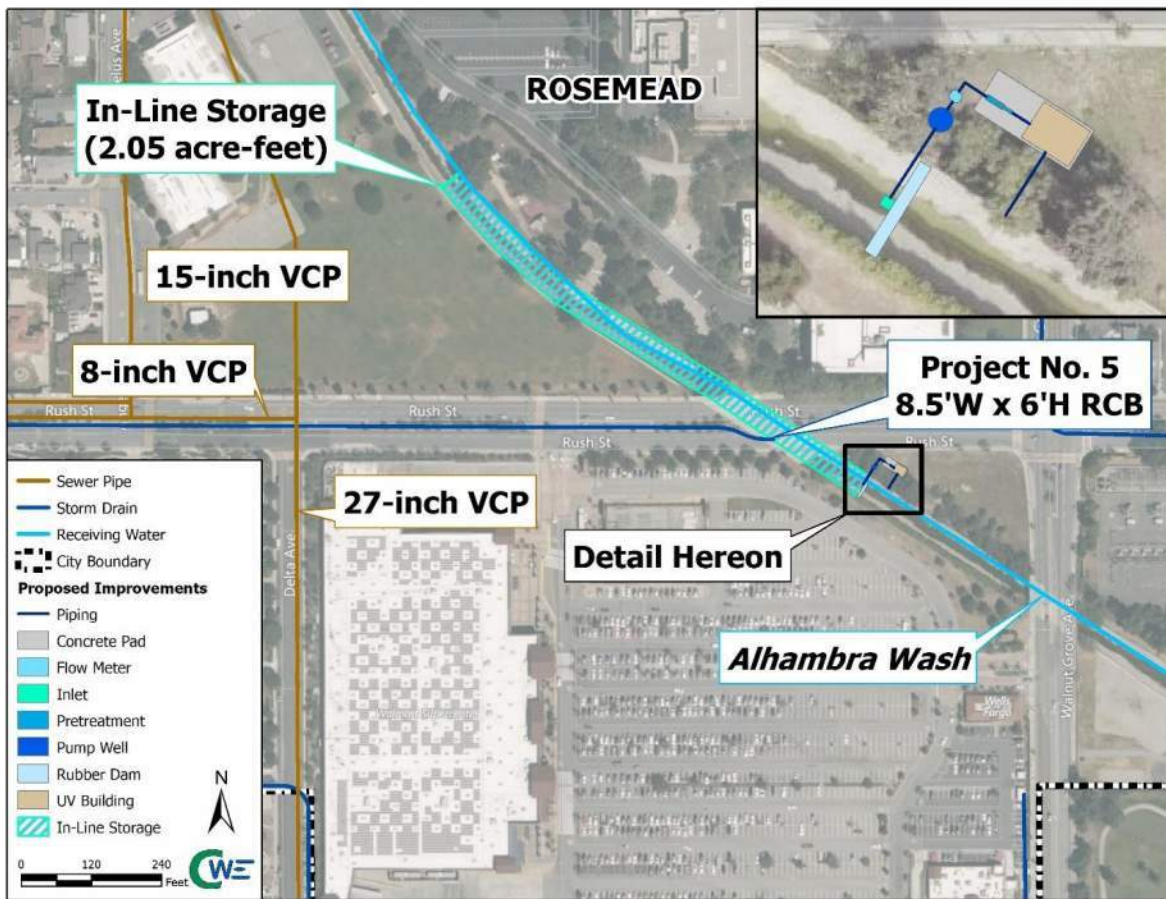
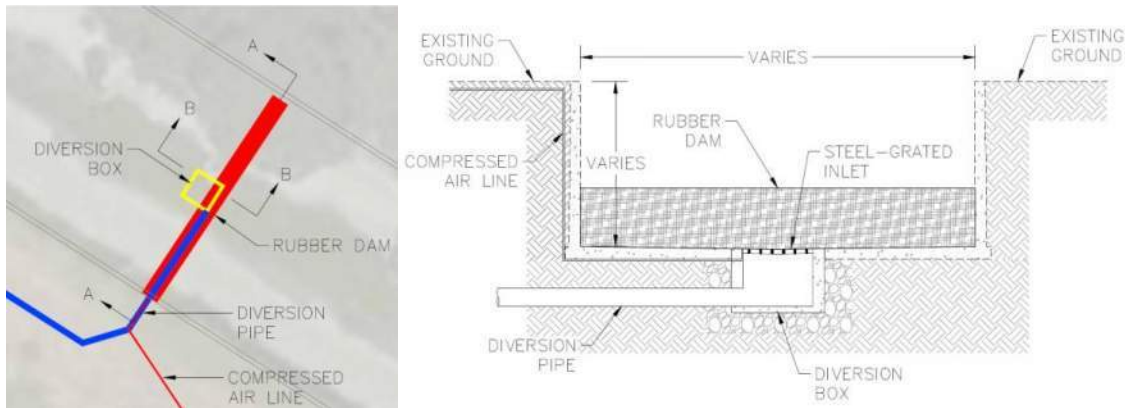

**Figure 3-1 Alhambra Wash Diversion Concept**

Runoff will be diverted from Alhambra Wash using a rubber dam and diversion system (inlet and pipe). The rubber dam allows runoff to accumulate in the channel before being diverted. This increases the capture efficiency and allows for in-line storage. Storage is helpful in providing flow equalization for the treatment system, allowing for a more consistent flow rate to be delivered for treatment. The rubber

dam will provide up to 2.05 acre-feet of storage and the height of the dam will be finalized during the design process. Runoff will be pumped into a pretreatment system and then through the UV treatment system before being discharged back to Alhambra Wash. The UV system and other equipment will be housed in an enclosure/building.

**Figure 3-2** illustrates a preliminary schematic of the rubber dam and inlet diversion system. This approach has been used throughout the region and has been approved by Los Angeles County Flood Control District (LACFCD) within the open channel systems they operate and maintain. The rubber dam will require the installation of a control structure to which the compressed air line will connect. The control structure will be located within the onsite enclosure/building.



**Figure 3-2 Rubber Dam and Diversion Box**

During wet-weather events, the rubber dam will deflate and flatten to mimic the existing channel bottom, allowing runoff to bypass the diversion system. The rubber dam will not have a significant effect on the Water Surface Elevation (WSE) during the design event (high storm flows), while there will be some changes at the invert. Modeling during the final design will quantify the impact on the WSE. Alhambra Wash was originally constructed by the United States Army Corps of Engineers (USACE). Improvements within the channel right-of-way will be reviewed by both LACFCD and USACE during the design process. A detailed hydraulic analysis will be performed and submitted for review.

The pump system will lift diverted flows to the treatment system. As mentioned above, the pump system (and diversion) will be controlled by a rain gage, which is expected to be onsite. Weather data pertaining to the tributary drainage area may be incorporated into the control system, which will be determined during the final design phase. A summary of the key pump components is included in **Table 3-2**.

**Table 3-2 Summary of Key Pump Components**

Component	Description
Pump well	<ul style="list-style-type: none"> <li>➤ Concrete that can withstand H-20 loading (likely precast)</li> <li>➤ Varying diameters, anticipated to be 10-12 feet</li> <li>➤ Varying depths, anticipated to extend approximately 7 feet beneath channel bottom</li> <li>➤ Perforations will allow for infiltration to occur</li> </ul>

Component	Description
Pump/motor	<ul style="list-style-type: none"> <li>➤ Submersible pump</li> <li>➤ Requires a Variable Frequency Drive (VFD) to allow for varying flow rate to be pumped, up to the peak rates in <b>Table 3-1</b></li> <li>➤ Redundant pump proposed (two pump system with one operating at a time)</li> </ul>
Valves/meters	<ul style="list-style-type: none"> <li>➤ Various valves proposed to control pipe flow and prevent backflow</li> <li>➤ Check valve will be placed on discharge line, potentially on vertical segment within wet well to eliminate need for valve vault</li> <li>➤ Flow meter with separate vault required on force main to quantify flows captured and treated</li> </ul>
Supervisory Control and Data Acquisition (SCADA)	<ul style="list-style-type: none"> <li>➤ May be used to control system</li> <li>➤ Will likely utilize/tie into LACFCD SCADA system</li> </ul>
Electrical service	<ul style="list-style-type: none"> <li>➤ Will requires separate service (likely from Southern California Edison [SCE])</li> <li>➤ May require local upgrades if capacity is not available (anticipated to require three phase, 480 volts)</li> <li>➤ Panel will be required onsite</li> </ul>

UV, coupled with the pretreatment device, will be used to actively remove microbial organism from diverted runoff. The pretreatment device will remove sediments and suspended solids. The diversion system will be designed to minimize the diversion of trash and debris. Site-specific monitoring will be performed during the design process to identify the influent water quality, which may influence the type of pretreatment used. It is currently anticipated that a fine mesh screen will be sufficient.

UV lamps will be used to expose flows to UV radiation, which will kill bacteria. The UV treatment equipment will be housed within an enclosure/building, as illustrated in the concept above. UV kills microorganisms when UV rays strike the cell. UV energy penetrates the outer cell membrane, passes through the cell body, and disrupts its DNA, which prevents reproduction. UV treatment does not alter water chemically; nothing is being added except energy. Microorganisms are not removed from the water, but deactivated. The degree of deactivation is directly related to the UV dose applied to the water. The dosage is a product of UV light intensity and exposure time, measured in watt per square centimeter. The required UV dosage is based on existing water quality and desired discharge quality. Additional water quality data and testing will be required to determine the appropriate dosage and pretreatment system.

UV treatment is most effective when levels of turbidity and suspended solids are low, as cloudy water prevents UV rays from penetrating the full water column. Pretreatment will be used to remove the suspended solids, which could otherwise shield the bacteria, allowing it to move through the system without being exposed to the UV radiation. UV treatment does not provide any residual effects downstream. It is possible that bacteria could regrow within the washes downstream of treatment. The treatment system will require a connection to the sanitary sewer for backflushing.





## 4. Project Benefits

The Alhambra Wash diversion provides dry-weather water quality benefits by reducing the pollutant loads reaching downstream receiving waters (Rio Hondo) by diverting and treating runoff. Runoff will be captured, treated, and discharged back into the channel. This benefit can be categorized as a pollutant load removed from the system. The benefits and metrics are summarized in **Table 4-1** below.

**Table 4-1 Summary of Project Benefits and Metrics**

Benefit	Metric	Description
Water Quality	Acre-feet (AF) Acre-feet per year (AFY)	Volume of polluted runoff diverted and treated.
	Most Probable Number (MPN) MPN per year (MPN/year)	Pollutant concentration (bacteria) multiplied by volume capture = load removed.

The Alhambra Wash diversion may also provide community and environmental benefits, which will be finalized during the design process, as summarized below:

- Plant street trees on Rush Street near diversion site
- Incorporate a swale to improve surface water quality and educate the community
- Educate local communities through outreach events
- Educate local communities with educational signage onsite
- Promote infiltration in the pump wet well to mimic natural process

## 5. Monitoring Approach

SGVCOG anticipates being awarded funding for the Project, which typically requires implementation of a monitoring program to determine if the benefits anticipated are provided by the Project, specifically in the initial time following implementation. The Project will include a flow meter downstream of the diversion pump station. The flow meter will collect volumetric data that will become an integral part of quantifying Project benefits. The readings captured on the flow meter will be downloaded periodically to identify how much volume was captured and treated through the Alhambra Wash diversion. These readings will provide the water quality benefit in acre-feet (AF) or acre-feet per year (AFY).

Grab samples will be taken upstream of the treatment system (in the channel upstream of the diversion, in the drop inlet, or in the pump wet well) to quantify the pollutant concentration of the system inflow. A more detailed monitoring plan will be developed to identify the grab sample procedures, exact location, and frequency. It is anticipated that bacteria loads will be quantified at a minimum in association with the Bacteria TMDL. Other pollutants may also be analyzed for in association with other downstream impairments. Results from water quality monitoring (concentrations) will be used with the volume capture readings from the flow meter to approximate the total pollutant load removed by the Project. The data collected with the flow meter and grab samples would be used to quantify the water quality benefit as MPN and/or MPN per year.



---

## **ATTACHMENTS FOR SECTION 2.6:**

**O & M**

---

# **San Gabriel Valley Council of Governments Load Reduction Strategy Projects Operation and Maintenance Manual**

**Prepared for:**



San Gabriel Valley Council of Governments  
1000 Fremont Ave #42, Alhambra, CA 91803  
TEL (626) 457-1800

**Prepared by:**



1561 E. Orangethorpe Avenue, Suite 240  
Fullerton, California, 92831

TEL (714) 526-7500 | FAX (714) 526-7004 | [www.cwecorp.com](http://www.cwecorp.com)

**September 2020**

# Table of Contents

**LIST OF FIGURES ..... i**

**LIST OF TABLES..... i**

**ACRONYMS .....ii**

**1. INTRODUCTION..... 1**

    1.1 PURPOSE.....1

    1.2 PROPOSED IMPROVEMENTS .....1

    1.3 LOCATION OF THE PROJECT .....3

    1.4 REFERENCES .....4

**2. PROJECT DESCRIPTION ..... 5**

    2.1 OPERATION .....5

    2.2 MAINTENANCE AND INSPECTIONS .....5

    2.3 EMERGENCY OPERATIONS.....7

    2.4 REPAIR, REPLACEMENT, REHABILITATION, AND REMOVAL .....7

    2.5 REGULATORY REQUIREMENTS .....7

    2.6 THIRD PARTY AGREEMENTS .....7

**3. COST ..... 8**

## Appendices

Appendix A Marked-Up Pages from Current O&M Manual

Appendix B As-Built Drawings

Appendix C Technical Specifications

Appendix D Catalog Cut Sheets and Pertinent Data

Appendix E Inspection and Maintenance Logs

Appendix F Electronic Version

## List of Figures

Figure 1-1 Alhambra Wash Proposed Conditions .....2

Figure 1-2 Eaton Wash Proposed Conditions .....2

Figure 1-3 Rubio Wash Proposed Conditions .....3

## List of Tables

Table 1-1 Parcel Numbers by Project Site .....3

Table 2-1 Inspection and Maintenance Summary .....6

Table 3-1 Anticipated Maintenance Cost .....8



## Acronyms

APN	Assessor Parcel Number
EWMP	Enhanced Watershed Management Program
LACFCD	Los Angeles County Flood Control District
LACPW	Los Angeles County Public Works
O&M	Operation and Maintenance
SGVCOG	San Gabriel Valley Council of Governments
TMDL	Total Maximum Daily Load
ULAR	Upper Los Angeles River
USACE	United States Army Corps of Engineers
UV	Ultra Violet
WQBEL	Water Quality Based Effluent Limitation

# 1. Introduction

The San Gabriel Valley Council of Governments (SGVCOG), on behalf of the County of Los Angeles (County) and the Cities of Alhambra, Monterey Park, Pasadena, Rosemead, San Gabriel, San Marino, South Pasadena, and Temple City is implementing the Load Reduction Strategy Projects for the Rio Hondo River and Tributaries. This Operation and Maintenance (O&M) Manual has been prepared to provide guidance for maintenance crews on the inspection and maintenance of the components included in the Dry-Weather Diversion Projects at Alhambra Wash, Eaton Wash, and Rubio Wash (Project). The manual outlines operation, inspection, and maintenance requirements and will include specifications, as-built plans, and maintenance/inspection logs following Project implementation. The manual follows the United States Army Corps of Engineers (USACE) format with some additional sections to meet the requirements of the Safe Clean Water Program. Specific inspection and maintenance tasks are presented in Section Maintenance and Inspections **2.2** along with the procedures for documentation of the work performed.

## 1.1 Purpose

The purpose of the Project is to help the agencies comply with the final dry-weather Water Quality Based Effluent Limitations (WQBELs), as specified by the Los Angeles River Bacteria Total Maximum Daily Load (TMDL). The Cities of Alhambra, Monterey Park, Pasadena, Rosemead, San Gabriel, San Marino, South Pasadena, and Temple City, along with Unincorporated County have thus entered into an agreement with the SGVCOG to implement the Project to address the bacteria TMDL. The Project consists of low flow diversions along Alhambra Wash, Eaton Wash, and Rubio Wash, which will address dry-weather bacteria discharges from more than 35,000 acres of tributary area within the Upper Los Angeles River (ULAR) Enhanced Watershed Management Program (EWMP) Group area. The flows will be diverted from each wash, treated, and then released back. Additional details pertaining to the proposed improvements are included in **Section 1.2**. Water quality is expected to improve by diverting dry-weather runoff before it reaches the Rio Hondo. The Project will assist with compliance with water quality regulations and will improve local water quality.

## 1.2 Proposed Improvements

The Project will involve the construction of a grated drop inlet within each wash that will collect low flows. A rubber dam will be installed to provide in-line storage and assist in facilitating capture through the drop inlet. A gravity-driven pipe will be installed and will direct low flows underneath the channel bottom to a proposed pump station within the access road. The diversion pipe will be located deep enough to avoid the channel wall's footing and/or minimize impacts to the channel walls. The pump station will be located within the access road or within the adjacent property, which may require acquisition or easements at Alhambra Wash and Rubio Wash. A treatment system, including pretreatment and Ultra Violet (UV) treatment, will be used before runoff is discharged back into the washes. **Figure 1-1**, **Figure 1-2**, and **Figure 1-3** illustrate the improvements at Alhambra Wash, Eaton Wash, and Rubio Wash, respectively, that will be constructed as part of the Project. As-builts will be included in **Appendix B** following construction of the Project.

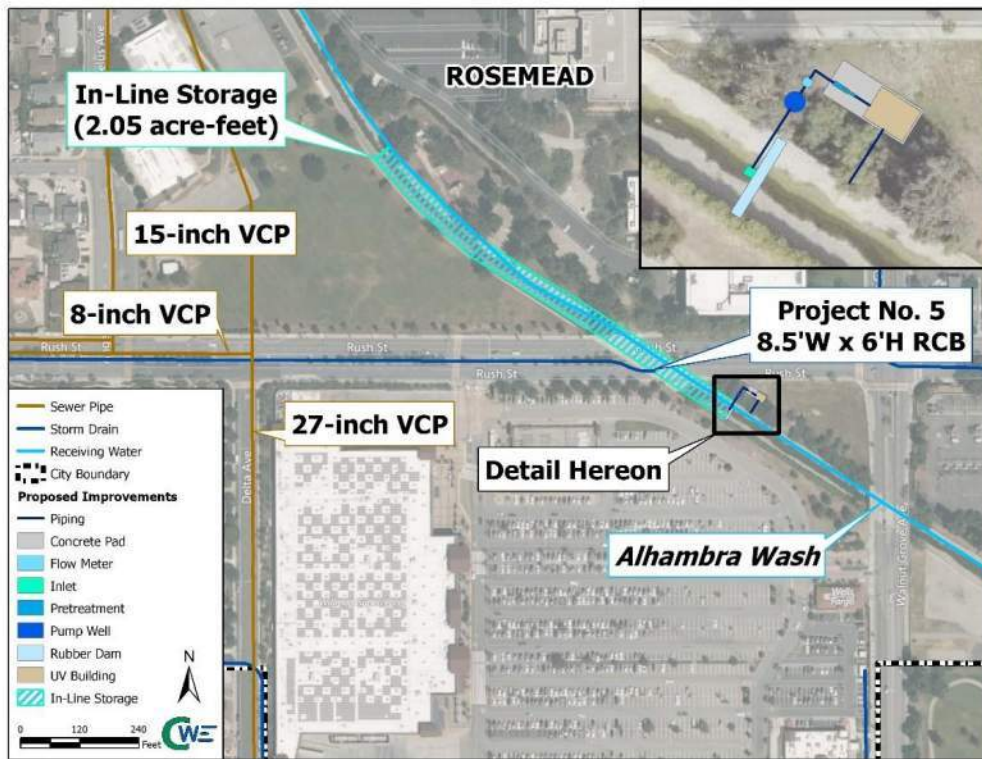

Figure 1-1 Alhambra Wash Proposed Conditions

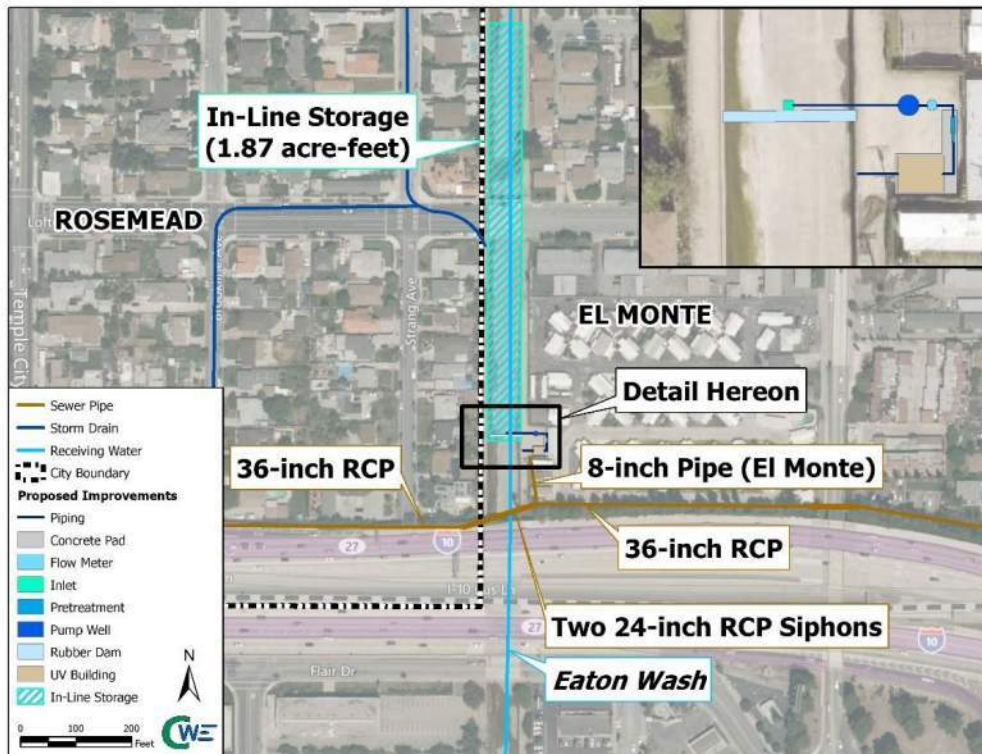

Figure 1-2 Eaton Wash Proposed Conditions





Figure 1-3 Rubio Wash Proposed Conditions

### 1.3 Location of the Project

The Project is located within and adjacent to existing open channels as illustrated in the figures above. The sites are located within Los Angeles County Flood Control District (LACFCD) right-of-way. Alhambra Wash (City of Rosemead), Eaton Wash (City of Rosemead), and Rubio Wash (City of El Monte) are flood control facilities constructed by the USACE and operated and maintained by LACFCD. Following Project completion, the proposed Project improvements in the channel access road will be accessible to maintenance crews via existing maintenance ramps and entrances. The Project will encroach within LACFCD right-of-way as illustrated above (within the channel and access road). Improvements are anticipated within the parcels listed in **Table 1-1** by their Assessor Parcel Numbers (APNs).

Table 1-1 Parcel Numbers by Project Site

Site	Parcels (APNs)	Ownership
Alhambra Wash	5279-033-801	Southern California Edison with LACFCD easement
Eaton Wash	8578-005-904	LACFCD
Rubio Wash	8595-016-024	Private owner with LACFCD easement
	8595-017-018 and 8595-017-019,	Adjacent private owner

## 1.4 References

The channel is currently operated and maintained by LACFCD based on their established procedures. Existing O&M procedures are not included in this O&M Manual, as the Project components will be inspected, operated, and maintained separate from the existing systems, as described in this manual. References and technical specifications for the pumps and flow meter are attached in **Appendix C** and **Appendix D**.

## 2. Project Description

Regular maintenance and inspection schedules are necessary to preserve the Project's effectiveness and longevity. The following sections detail the necessary tasks required to operate, inspect, and maintain the Project's components.

### 2.1 Operation

The main system components include the diversion system (rubber dam, inlet, and pipe), pump station with appurtenances, pretreatment system, treatment system, and flow meter. Once in place, the grated inlet will not require any specific operations, as it will function on its own. Inspections and maintenance related to the diversion system is further discussed below.

The rubber dams and pump stations will operate automatically based on controls put into place during construction. The rubber dams will be inflated during low flow periods and will deflate automatically during high flow periods based on an onsite rain gage or other automated systems. The pump systems will have two pumps for redundancy in case one of the pumps breaks down or needs to be serviced. The pumps will operate one at a time and will alternate operations to reduce overuse and prolong their lifespan. The pumps will only operate during low flows and will automatically shut-off during high flow periods. The wet well will be filled with water to the level set point before the pumps turn on. When the pump is in the operation, the valves and piping associated with the pump will be utilized. The pump system does not require manual operation. Inspection and maintenance related to the pump system is further discussed below. The flow meters on the pump discharge lines (force mains) will not require manual operation. Flow data will be logged based on the programming established during construction.

Los Angeles County Public Works (LACPW) will be responsible for maintenance on behalf of the group and contact information is as follows:

Los Angeles County Public Works  
900 S. Fremont Avenue  
Alhambra, CA 91803

### 2.2 Maintenance and Inspections

Descriptions of the operation/maintenance and inspection frequency of the Project's components are listed in **Table 2-1** Error! Reference source not found.. LACPW staff and/or contracted specialist will perform maintenance and inspection on the Project components and record them in the logs included in **Appendix E**.

**Table 2-1 Inspection and Maintenance Summary**

Component	Operation/Maintenance	Inspection Frequency
Rubber Dam	<ul style="list-style-type: none"> <li>➤ Inspect for air leaks</li> <li>➤ Annual preventative maintenance includes inspection/replacement of the compressor mechanical seals, greasing or replacing compressor motor bearings, cleaning/replacing compressor air filters, and inspection and exercising of the inflation and deflation control valves and actuators</li> </ul>	Before and after the storm season (twice per year)
Diversion System (inlet and pipe)	<ul style="list-style-type: none"> <li>➤ Inspect for accumulated sediment and debris over grate and within concrete basin</li> <li>➤ Remove accumulated sediment and debris (litter and leaves) from the grate and inside the inlet</li> <li>➤ Inspect conveyance pipe for clogging</li> <li>➤ Remove accumulated materials from the pipe system</li> </ul>	Before and after the storm season (twice per year)
Pump System	<ul style="list-style-type: none"> <li>➤ Inspect pump well for sediment and debris and remove as necessary</li> <li>➤ Check valves for operation and clogging</li> <li>➤ Clear material and replace valves as necessary</li> <li>➤ Inspect bearings and impeller for wear</li> <li>➤ Lubricate bearings as needed</li> <li>➤ Check pump for operation</li> <li>➤ Verify pump levels have been maintained</li> <li>➤ Consult manufacturer if pump has not been operated in more than 12 months or if more extensive maintenance is required</li> <li>➤ During operation, check pump for excessive noise, vibration, or other abnormal conditions</li> </ul>	Twice per year (minimum)
Flow Meter	<ul style="list-style-type: none"> <li>➤ Inspect flow data to identify anomalies</li> <li>➤ Troubleshoot with manufacturer if data anomalies observed</li> <li>➤ Mostly maintenance free, but should be calibrated annually</li> </ul>	Once per year
Pretreatment System	<ul style="list-style-type: none"> <li>➤ Inspect for blockages or obstructions in the inlet and treatment section</li> <li>➤ Clear blockages or obstructions if observed</li> <li>➤ Inspect sump to assess volume of sediment and debris accumulated and remove as necessary</li> <li>➤ Inspect screen for clogging/damage and clean/replace as necessary</li> </ul>	Twice per year
Treatment System	<ul style="list-style-type: none"> <li>➤ Clean quartz sleeves and quartz window on a regular basis</li> <li>➤ Replace automatic wiper system after 7,000 wiper movements or at least once per year</li> <li>➤ Replace UV lamps approximately every 8,000 to 10,000 hours of run time or once per year</li> </ul>	Periodically or as determined by the manufacturer or maintenance staff
Mosquito/Vector Screens/Barriers	<ul style="list-style-type: none"> <li>➤ Inspect screen/barrier for rips or holes</li> <li>➤ Replace screen/barrier if damage is observed</li> </ul>	Quarterly

## 2.3 Emergency Operations

During storm events or periods of high flow, the pump station will automatically shut off and storm flows will back up into the existing washes and continue as they would under existing conditions. The pump will automatically turn back on once flows have decreased and rain has not been measured within the past 48-72 hours. The pump may also turn off if it becomes clogged with debris. All maintenance procedures shall comply with the latest Occupational Safety and Health Administration (OSHA) standards. In case of a power failure or equipment breakdown, the system will not operate. Under any type of emergency, the system will be shut down (automatically or manually) and there will not be any concerns with flood control operations.

## 2.4 Repair, Replacement, Rehabilitation, and Removal

The proposed improvements, including the rubber dam, diversion system, pump system, flow meter, pretreatment system, and treatment system, shall be inspected and maintained on a regular basis, as detailed in **Table 2-1**. It is recommended that the pump station and treatment system be maintained by qualified personnel at least twice per year or as recommended by the manufacturer. If damage is observed, parts will be removed, replaced, and/or repaired based on the manufacturer's recommendations. Detailed product information will be submitted to SGVCOG by the selected Contractor, including O&M protocols, prior to construction.

## 2.5 Regulatory Requirements

All the described inspection and maintenance activities are exempt from a USACE permit.

## 2.6 Third Party Agreements

A Use and Maintenance Agreement between LACFCD and SGVCOG allows for the installation and maintenance of a diversion system within each of the existing LACFCD channels included in the Project. The Use and Maintenance Agreement outlines the responsibilities of each party. The Use and Maintenance Agreement will be issued during the final design phase.

### 3. Cost

**Table 3-1** summarizes the anticipated maintenance cost for one (1) site. The maintenance cost is based on the number of crews/staff required, staff level expertise, and hours of maintenance per year. The hourly rate is based on general industry averages and may vary depending on whether LACPW will maintain the systems or hire a maintenance team. It is expected that at least two laborers are onsite performing maintenance. The hourly projections may also vary depending on the final equipment constructed. These projections will be updated following construction. In addition to the maintenance costs projected below, it is anticipated that approximately \$34,000 of operational costs will exist per year in association with sewer discharge, inspection, and utility (electrical and other) fees. Costs will likely increase about 3% annually based on inflation, which is not shown in the table below.

**Table 3-1 Anticipated Maintenance Cost**

Component	Frequency	Hours by Position per Year			Equipment Rental	Total Cost
		Superintendent	Foreman	Laborer		
		\$150	\$120	\$75		
Rubber Dam	Twice per year	18	54	108	Equipment used for many of the components	\$17,280
Diversion System (inlet and pipe)	Twice per year	12	36	72		\$11,520
Pump System	Twice per year	16	48	96		\$15,360
Flow Meter	Once per year	4	12	24		\$3,840
Pretreatment System	Twice per year	12	36	72		\$11,520
Treatment System	Periodically	12	36	72		\$11,520
Mosquito/Vector Screens/Barriers	Quarterly	4	12	24		\$3,840
<b>TOTAL:</b>		<b>78</b>	<b>234</b>	<b>468</b>	<b>\$6,120</b>	<b>\$81,000</b>

# **Appendix A**

## **Marked-Up Pages from Current O&M Manual**



This appendix is not applicable (no previous O&M Manual)





# **Appendix B**

## **As-Built Drawings**



As-built drawings will be included upon Project completion



# Appendix C

## Technical Specifications



Technical specifications will be included upon Project completion



# Appendix D

## Catalog Cut Sheets and Pertinent Data



Catalog cut sheets and pertinent data will be included upon Project completion



# Appendix E

## Inspection and Maintenance Logs



**Rubber Dam Inspection and Maintenance Log**

Date	Inspection/Maintenance Personnel	Inspection/Maintenance Performed	Additional Notes





**Diversion System Inspection and Maintenance Log**

Date	Inspection/Maintenance Personnel	Inspection/Maintenance Performed	Additional Notes



**Pump Station Inspection and Maintenance Log**

Date	Inspection/Maintenance Personnel	Inspection/Maintenance Performed	Additional Notes



**Flow Meter Inspection and Maintenance Log**

Date	Inspection/Maintenance Personnel	Inspection/Maintenance Performed	Additional Notes



**Pretreatment System Inspection and Maintenance Log**

Date	Inspection/Maintenance Personnel	Inspection/Maintenance Performed	Additional Notes



**Treatment System Inspection and Maintenance Log**

Date	Inspection/Maintenance Personnel	Inspection/Maintenance Performed	Additional Notes



**Mosquito Screen/Barrier Inspection and Maintenance Log**

Date	Inspection/Maintenance Personnel	Inspection/Maintenance Performed	Additional Notes



# **Appendix F**

## **Electronic Version**



CD/electronic versions will be inserted here in hard copy







October 14, 2020

The San Gabriel Valley Council of Governments (SGVCOG) is seeking funding in partnership with the County of Los Angeles and the Cities of Alhambra, Monterey Park, Pasadena, Rosemead, San Gabriel, San Marino, South Pasadena, and Temple City for the Load Reduction Strategy Projects for the Rio Hondo River and Tributaries (Project) through the Regional Safe Clean Water Program (SCWP). The regional dry-weather multi-benefit project provides water quality and community benefits. Dry-weather flows will be diverted from Alhambra, Eaton, and Rubio Washes, treated with advanced ultra-violet systems and discharged back into the respective water bodies. The Project captures dry-weather runoff generated in an area greater than 35,000 acres, which receives runoff from the partnering jurisdictions identified above. The Project assists the region in addressing dry-weather water quality goals associated with the Los Angeles River Bacteria Total Maximum Daily Load (TMDL) and improving water quality in Rio Hondo and ultimately the Los Angeles River.

The SGVCOG as the subregional agency with jurisdiction over the project area is acting as lead agency for the project under an agreement with the County of Los Angeles and the Cities of Alhambra, Monterey Park, Pasadena, Rosemead, San Gabriel, San Marino, South Pasadena, and Temple City. The SGVCOG will collaborate with these agencies to procure resources to oversee operation and maintenance of the Project's components either through internal staffing, consultant services, or a combination of both. These components include but are not limited to the following:

- Rubber dam
- Diversion structure and piping
- Pump station
- Flow meter
- Treatment components (including pretreatment)

If you have any questions or require additional information, please me at 626-962-9292 or at [mchristoffels@SGVCOG.org](mailto:mchristoffels@SGVCOG.org)

Respectfully,

  
Mark Christoffels  
Chief Engineer



---

## **ATTACHMENTS FOR SECTION 3.2:**

### **DRY WEATHER INFO**

---



---

## **ATTACHMENTS FOR SECTION 4.1:**

**NEXUS**

---

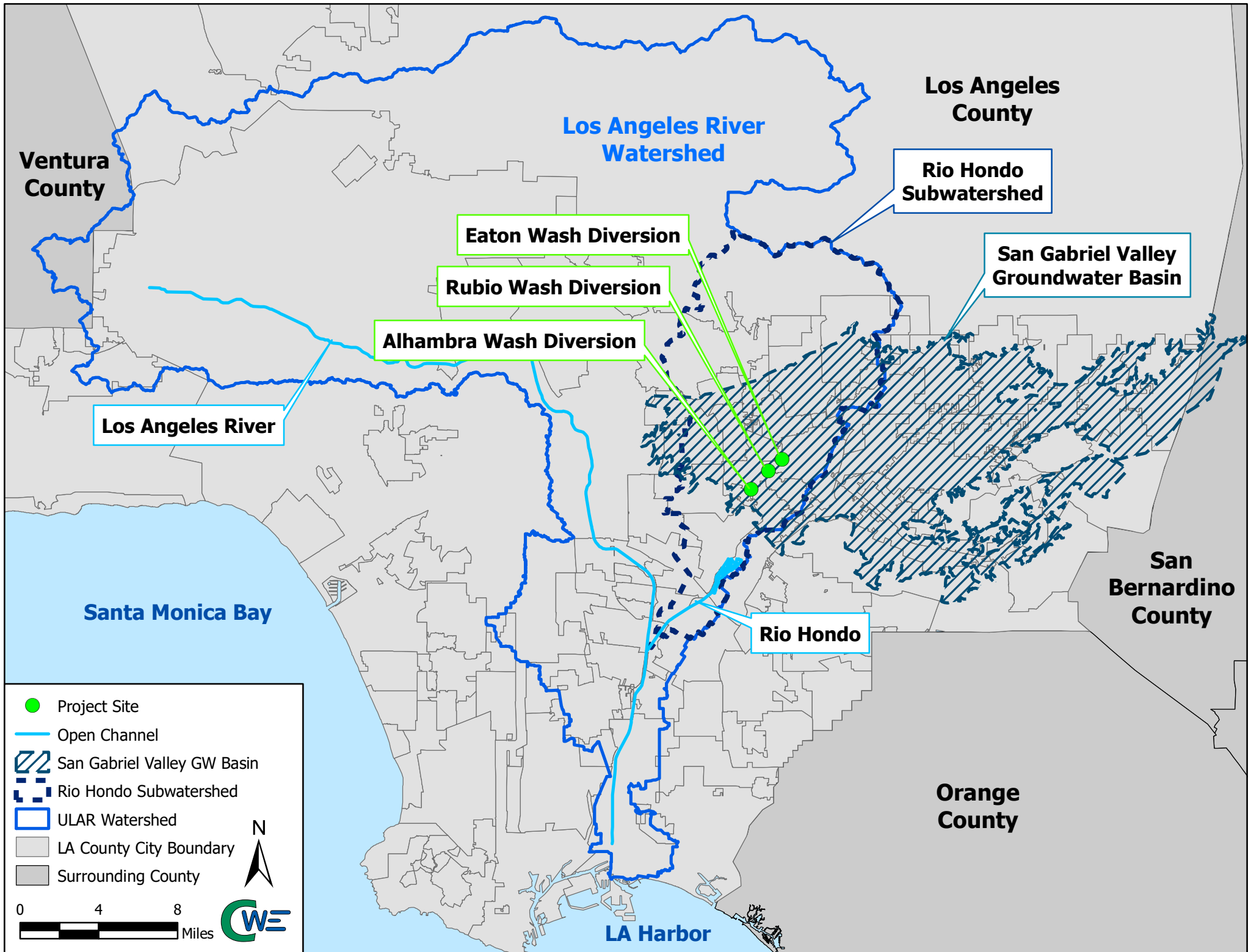

Ventura County

Los Angeles River Watershed

Los Angeles County

Rio Hondo Subwatershed

Eaton Wash Diversion

Rubio Wash Diversion

San Gabriel Valley Groundwater Basin

Alhambra Wash Diversion

Los Angeles River

Santa Monica Bay

San Bernardino County

Rio Hondo

Orange County

LA Harbor

- Project Site
- Open Channel
- San Gabriel Valley GW Basin
- Rio Hondo Subwatershed
- ULAR Watershed
- LA County City Boundary
- Surrounding County

N

0      4      8  
 Miles



---

## **ATTACHMENTS FOR SECTION 4.2:**

### **BENEFIT MAGNITUDE**

---



---

## **ATTACHMENTS FOR SECTION 4.3:**

### **COST EFFECTIVENESS**

---



---

## **ATTACHMENTS FOR SECTION 5.1:**

### **COMMUNITY INVESTMENT**

---

# Alhambra Wash Dry-Weather Diversion Project

Project in City of Rosemead



plant trees in sidewalk

educational sign

Rush St

swale

Walnut Grove Ave

603



Amenities shown are under review with local jurisdictions and will be finalized (size, location, and quantity) during the design process



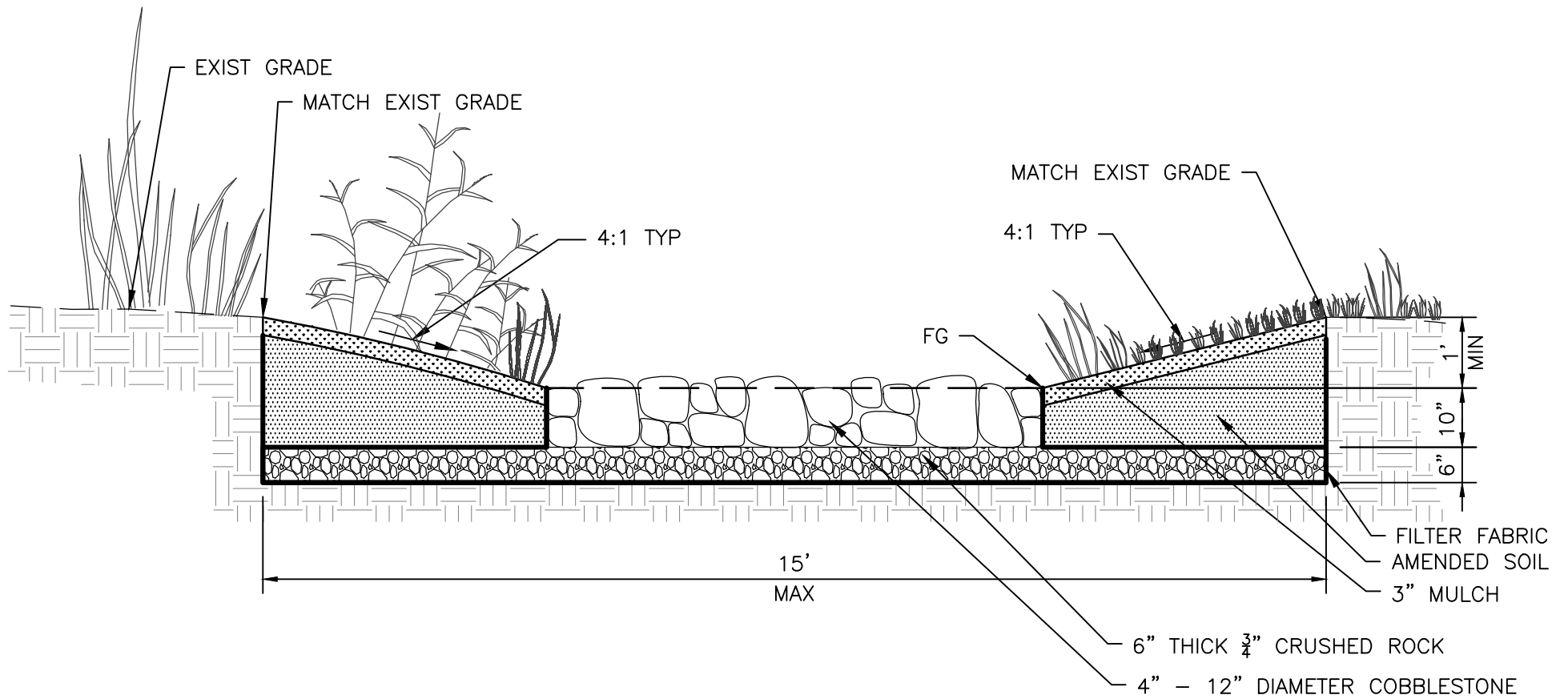

1

**PRELIMINARY BIOSWALE DETAIL**

NOT TO SCALE



---

## **ATTACHMENTS FOR SECTION 5.2:**

### **LOCAL SUPPORT**

---



MARK PESTRELLA, Director

# COUNTY OF LOS ANGELES

## DEPARTMENT OF PUBLIC WORKS

*"To Enrich Lives Through Effective and Caring Service"*

900 SOUTH FREMONT AVENUE  
ALHAMBRA, CALIFORNIA 91803-1331  
Telephone: (626) 458-5100  
<http://dpw.lacounty.gov>

ADDRESS ALL CORRESPONDENCE TO:  
P.O. BOX 1460  
ALHAMBRA, CALIFORNIA 91802-1460

October 13, 2020

IN REPLY PLEASE

REFER TO FILE:

SWQ-5

Mr. Mark Christoffels  
San Gabriel Valley Council of Governments  
4900 Rivergrade Road, Suite A120  
Irwindale, CA 91706

Dear Mr. Christoffels:

### **LOAD REDUCTION STRATEGY PROJECTS FOR THE RIO HONDO RIVER AND TRIBUTARIES LETTER OF SUPPORT**

Los Angeles County Public Works would like to express our support for the Load Reduction Strategy Projects for the Rio Hondo River and Tributaries and submittal for consideration as a Safe, Clean Water project as part of the Fiscal Year 2021-22 Stormwater Investment Plan.

The project is comprised of a system that would divert dry-weather flows from Alhambra, Eaton, and Rubio Washes for advanced ultra-violet treatment. The project is critical to addressing dry-weather bacteria in the Rio Hondo Channel and Los Angeles River.

Public Works welcomes the opportunity to participate as a project collaborator with the San Gabriel Valley Council of Governments and the Cities of Alhambra, Monterey Park, Pasadena, Rosemead, San Gabriel, San Marino, South Pasadena, and Temple City, and looks forward to its development.

If you have any questions, please contact me at (626) 458-4325 or [palva@pw.lacounty.gov](mailto:palva@pw.lacounty.gov) or your staff may contact Mr. Mark Lombos at (626) 458-7143 or [mlombos@pw.lacounty.gov](mailto:mlombos@pw.lacounty.gov).

Very truly yours,

MARK PESTRELLA  
Director of Public Works

PAUL ALVA  
Assistant Deputy Director  
Stormwater Quality Division

TM:dw

P:\swqpub\Sec\2020\Ltr\RH LRS Letter of Support\SGVCOG RH LRS Letter of Support.docx



10/14/2020

San Gabriel Valley Council of Governments  
Attention: Mark Christoffels  
4900 Rivergrade Road, Suite A120  
Irwindale, California 91706

**Load Reduction Strategy Projects for the Rio Hondo River and Tributaries  
Letter of Support**

Dear Mr. Mark Christoffels,

We understand the San Gabriel Valley Council of Governments (SGVCOG) is seeking funding in partnership with County of Los Angeles (County) and the Cities of Alhambra, Monterey Park, Pasadena, Rosemead, San Gabriel, San Marino, South Pasadena, and Temple City for the Load Reduction Strategy Projects for the Rio Hondo River and Tributaries (Project), which involves diverting dry-weather flows from Alhambra, Eaton, and Rubio Washes for advanced treatment using Ultra Violet (UV) treatment. We are aware the Project will capture dry-weather runoff from a drainage area greater than 35,000 acres, which includes areas within the partnering jurisdictions identified above. It is understood that the Project will assist the region in addressing dry-weather goals associated with the Los Angeles River Bacteria Total Maximum Daily Load (TMDL), improving water quality in the Rio Hondo and Los Angeles River.

Amigos de los Rios supports the Project and the City's efforts to improve dry-weather water quality in the region and in the Rio Hondo. The Project takes steps towards meeting water quality goals while also enhancing the community. We understand opportunities to plant trees, add green space in adjacent streets, and use solar power to support operations are currently under evaluation and we hope some of these opportunities will be realized.

If you have any questions or require additional information, please contact Claire Robinson at (626) 676 – 5027 or at [Claire@AmigosdelosRios.org](mailto:Claire@AmigosdelosRios.org).

Respectfully submitted,

Claire Robinson  
Managing Director  
Amigos de los Rios



---

## **ATTACHMENTS FOR SECTION 7.1:**

### **COST & SCHEDULE**

---



SGVCOG LRS Low-Flow Diversions  
 Conceptual Estimate of Probable Project Cost  
 Alhambra Wash Dry-Weather Diversion  
 Prepared By: CWE  
 Date: 06/15/2020

**Preliminary Construction Cost Opinion for Alhambra Wash**

ITEM #	DESCRIPTION	UNIT	QUANTITY	UNIT PRICE	TOTAL
1	Mobilization (10%)	LS	1	\$192,500	\$192,500
2	Site Demolition	LS	1	\$60,000	\$60,000
3	Diversion Structure (Rubber Dam)	LS	1	\$650,000	\$650,000
4	Diversion Pipe (24" RCP)	LF	40	\$350	\$14,000
5	Pretreatment System	LS	1	\$142,500	\$142,500
6	Pump	LS	1	\$351,000	\$351,000
7	Discharge Pipe (Channel)	LF	40	\$100	\$4,000
8	Discharge Pipe/Sewer Connection	LS	1	\$68,500	\$68,500
9	UV Treatment System	LS	1	\$385,000	\$385,000
10	SCADA and Electrical Appurtenances	LS	1	\$250,000	\$250,000
Total					\$2,117,500
30% Contingency					\$635,300
<b>GRAND TOTAL</b>					<b>\$2,752,800</b>

**Preliminary Cost Opinion for Full Project**

ITEM #	DESCRIPTION	UNIT	QUANTITY	UNIT PRICE	TOTAL
A	Planning (Actual Costs)	LS	1	\$125,000	\$125,000
B	Design (10%)	%	10	\$275,300	\$275,300
C	Environmental/Permitting (10%)	%	10	\$275,300	\$275,300
D	Acquisition	LS	1	\$1,303,000	\$1,303,000
E	Construction Administration (15%)	%	15	\$413,000	\$413,000
F	Construction (Opinion Above)	LS	1	\$2,752,800	\$2,752,800
<b>GRAND TOTAL</b>					<b>\$5,144,400</b>



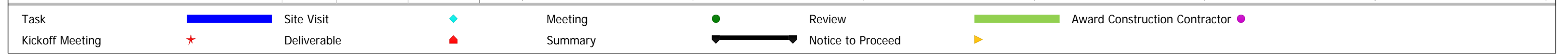
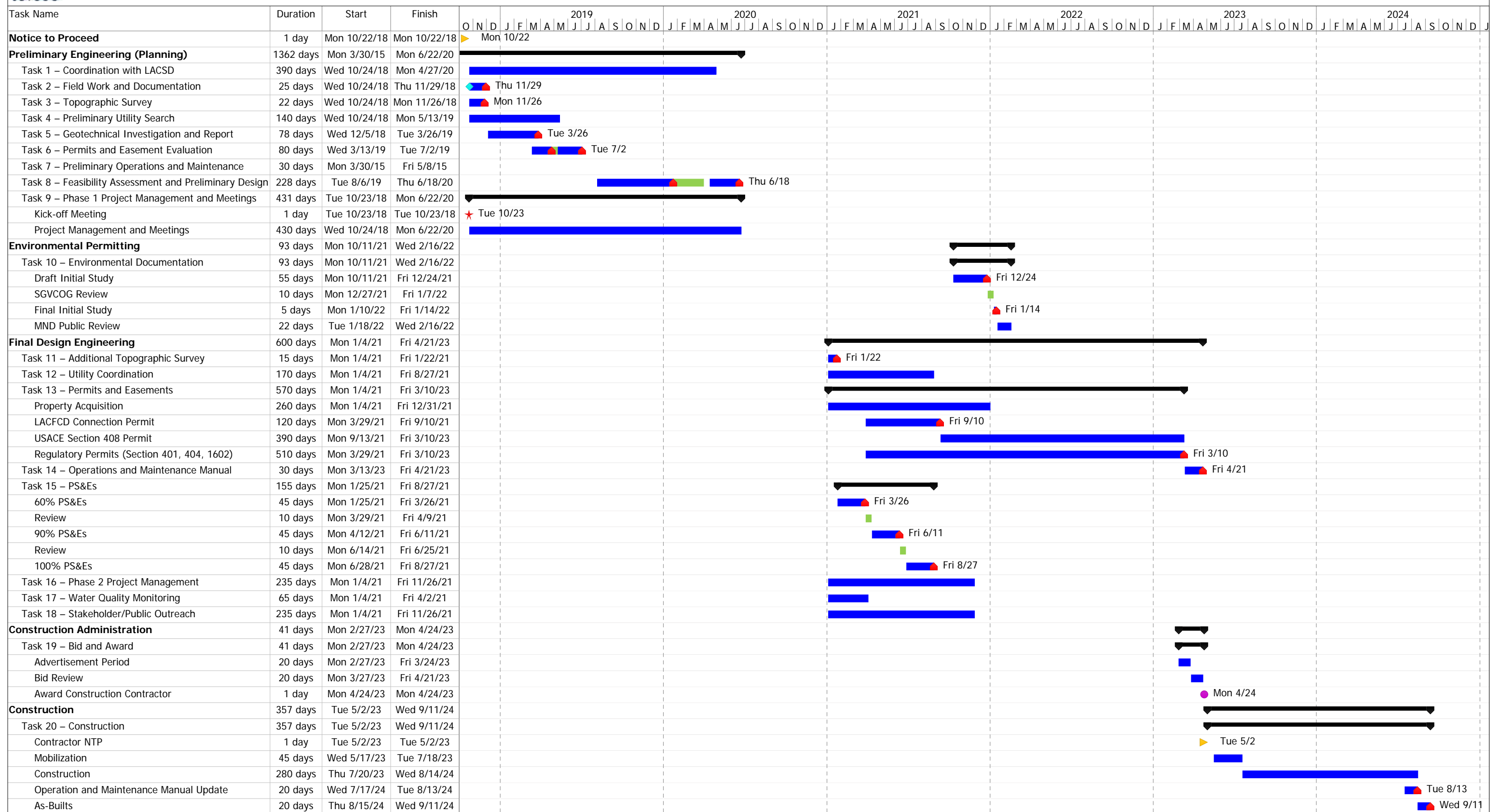







---

## **ATTACHMENTS FOR SECTION 7.2:**

### **COST SHARE**

---

## AGREEMENT

**BETWEEN THE COUNTY OF LOS ANGELES AND THE CITIES OF ALHAMBRA, MONTEREY PARK, PASADENA, ROSEMEAD, SAN GABRIEL, SAN MARINO, SOUTH PASADENA, AND TEMPLE CITY, AND THE SAN GABRIEL VALLEY COUNCIL OF GOVERNMENTS**

**REGARDING THE ADMINISTRATION AND COST SHARING FOR THE PREPARATION OF DESIGN PLANS FOR THREE LOAD REDUCTION STRATEGY PROJECTS FOR THE RIO HONDO RIVER AND TRIBUTARIES**

This AGREEMENT is made and entered into as of the date of the last signature set forth below by and among the SAN GABRIEL VALLEY COUNCIL OF GOVERNMENTS (SGVCOG), a California Joint Powers Authority, COUNTY OF LOS ANGELES (COUNTY), a political subdivision of the State of California, and the CITIES OF ALHAMBRA, MONTEREY PARK, PASADENA, ROSEMEAD, SAN GABRIEL, SAN MARINO, SOUTH PASADENA, and TEMPLE CITY, municipal corporations. Collectively, these entities shall be known herein as PARTIES or individually as PARTY.

### WITNESSETH

WHEREAS, for the purpose of this AGREEMENT, the term PARTIES shall mean the COUNTY, the SGVCOG, and the Cities of Alhambra, Monterey Park, Pasadena, Rosemead, San Gabriel, San Marino, South Pasadena, and Temple City;

WHEREAS, the Los Angeles Regional Water Quality Control Board (REGIONAL BOARD) has adopted National Pollutant Discharge Elimination System (NPDES) Municipal Separate Storm Sewer System (MS4) Permit Order No. R4-2012-0175; and

WHEREAS, the MS4 Permit became effective on December 28, 2012, and requires that the COUNTY, the LACFCD, and 84 of the 88 cities (excluding Avalon, Long Beach, Palmdale, and Lancaster) within the Los Angeles County comply with the prescribed elements of the MS4 Permit; and

WHEREAS, the MS4 Permit identifies the PARTIES, except SGVCOG, as MS4 permittees (PERMITTEES) that are responsible for compliance with the MS4 Permit requirements pertaining to the Los Angeles River Bacteria Total Maximum Daily Load (LAR Bacteria TMDL) Resolution No. R10-007; and

WHEREAS, the LAR Bacterial TMDL was adopted by the REGIONAL BOARD on July 9, 2010 and became effective March 23, 2012; and

WHEREAS, the LAR Bacteria TMDL requires the responsible PERMITTEES to protect recreational uses in the Los Angeles River watershed by meeting targets and waste load allocations (WLAs) for the indicator bacterium *E. coli*; and

WHEREAS, the PERMITTEES have agreed to collaborate on the development of a Load Reduction Strategy (LRS) for the PERMITTEES to comply with the LAR Bacteria TMDL; and

WHEREAS, the PERMITTEES have hired a consultant to develop the LRS for Rio Hondo River and Tributaries; and

WHEREAS, the COUNTY, on behalf of the PERMITTEES, submitted the Rio Hondo LRS to the REGIONAL BOARD on March 23, 2016, as shown in Attachment A; and

WHEREAS, the Rio Hondo LRS identifies twenty-six (26) priority outfalls that would have to be diverted or "turned off" by 2020 in order to meet the LAR Bacteria TMDL requirements for Alhambra Wash, Rubio Wash, Eaton Wash, and the Rio Hondo; and

WHEREAS, the regional phased approach proposes to construct three (3) diversions at the mouth of Alhambra Wash, Rubio Wash, and Eaton Wash; and

WHEREAS, the COUNTY, on behalf of the PERMITTEES, retained a consultant on September 13, 2016, as shown in Attachment B, to prepare a supplemental LRS document discussing the details of the regional phased approach, which was submitted to the REGIONAL BOARD on October 25, 2017, as shown in Attachment C; and

WHEREAS, the PERMITTEES have agreed that hiring a consultant to prepare the design plans and other planning activities for the three (3) regional phased projects as described in Attachment C will be beneficial to the PERMITTEES; and

WHEREAS, the PERMITTEES have agreed to cost share the preparation of design plans and other planning activities for three (3) regional phased projects; and

WHEREAS, the PARTIES have agreed to credit the COUNTY twenty-seven thousand five hundred twenty-four dollars (\$27,524) towards its cost share for providing consultant services to develop the supplemental LRS document discussing the regional phased approach; and

WHEREAS, the PARTIES have agreed that the total of each PARTY's cost share shall not exceed the total amount shown in Table 1 of Exhibit A; and

WHEREAS, the PARTIES have agreed to have the SGVCOG, under the direction of the PERMITTEES: (a) administer this AGREEMENT; (b) to retain and manage a consultant to prepare design plans and other planning activities; (c) negotiate and enter into agreements with consultants for as-needed services to prepare design plans and other planning activities for three (3) regional phased projects including acquisition of all environmental and jurisdictional approvals; and (d) invoice and collect funds from the PERMITTEES to cover the cost of the aforementioned consultant(s); and

NOW, THEREFORE, in consideration of the mutual benefits to be derived by the PERMITTEES, and of the promises contained in this AGREEMENT, the PARTIES agree as follows:

Section 1. Recitals. The recitals set forth above are fully incorporated into this AGREEMENT.

Section 2. Purpose. The purpose of this AGREEMENT is to cooperatively fund the preparation of design plans and other planning activities for three (3) LRS projects and to coordinate the payment between the PERMITTEES and SGVCOG.

Section 3. Cooperation. The PARTIES shall fully cooperate with one another to attain the purposes of this AGREEMENT.

Section 4. Voluntary. The PARTIES have voluntarily entered into this AGREEMENT for the preparation of design plans and other planning activities for three (3) LRS projects.

Section 5. Term. This AGREEMENT shall become effective to each PARTY on the date the last PARTY signs this AGREEMENT, and shall remain in effect until (1) the SGVCOG has provided written notice of completion of the design plans and all other planning activities, and (2) the SGVCOG has received payment by all PERMITTEES of their allocated pro-rata share hereunder.

Section 6. SGVCOG AGREES:

- a. Consultant Services. To act as lead agency and hire a consultant to prepare the PROJECT documentation required under the California Environmental Quality Act, and to deliver said documentation to the PERMITTEES, for their review, comment, and approval prior to formal adoption. To hire a consultant to prepare all required preliminary and final plans, specifications, and cost estimates for PROJECT, and to deliver said preliminary and final plans, specifications, and cost estimates to the PERMITTEES, for their review, comment, and approval thereof.
- b. Permits and rights of way. To acquire on behalf of PERMITTEES all required authorizations and jurisdictional permits from government agencies necessary to design and construct the PROJECT and to identify what rights of way may need to be acquired. Should PERMITTEES desire to have the SGVCOG acquire such rights of way, a separate agreement for that work will be required.
- c. Invoice. To invoice on a monthly basis the PERMITTEES for their respective share of the actual costs incurred by SGVCOG for the preparation and delivery of the design plans. Cost share shall be determined using the percentages shown in Table 3. Billing costs shall not exceed those shown in Table 1 with-out prior consent of Permittees.

- d. Expenditure. To utilize the funds deposited by the PERMITTEES only for the administration of the consultant contract(s) and the preparation of design plans and other planning activities for the LRS projects.
- e. Contingency. To notify the PERMITTEES if actual expenditures are anticipated to exceed the cost estimate shown in Exhibit A and obtain written approval of such expenditures from all PERMITTEES. A 10 percent contingency will be not be invoiced unless actual expenditures exceed the original cost estimate. Expenditures that exceed the 10 percent contingency will require an amendment to this AGREEMENT.
- f. Report. To provide the PERMITTEES with an electronic copy of the draft and final LRS design plans.
- g. Accounting. To provide an accounting upon termination of this AGREEMENT. At the completion of the accounting, SGVCOG shall return to PERMITTEES any unused portion of all funds deposited with SGVCOG in accordance with the cost allocation set forth in Exhibit A.
- h. Permit. To work with the consultant(s) to obtain all necessary permits and approvals for installation of permanent or temporary infrastructure, if needed, and/or modifications to monitoring sites, and access to storm drains, channels, catch basins, and similar properties (FACILITIES) during monitoring events and maintenance necessary to perform the services for which consultant(s) have been retained.
- i. Responsibility. Upon completion of all work under this AGREEMENT, SGVCOG will relinquish all ownership of design plans and products stemming from planning activities to the PERMITTEES.

Section 7. THE PERMITTEES AGREE:

- a. To provide SGVCOG all available plans, and survey data of existing PERMITTEE infrastructure necessary to design PROJECT.
- b. If the location of existing facilities of public and/or private utilities conflicts with the construction of PROJECT, SGVCOG will identify such facilities located within PERMITTEES' right of way and request that the PERMITTEES enforce available rights under existing franchise agreements or encroachment permits held by PERMITTEES for facilities' protection, relocation, or removal at no cost to SGVCOG. PERMITTEES may choose to authorize SGVCOG to coordinate and inspect such protection, relocation, or removal work, at PERMITTEES's discretion. Nothing in this AGREEMENT shall restrict or affect PERMITTEES's or SGVCOG's ability to enter into separate agreements with utilities for any purpose, including for reimbursements of utility costs for protection, relocation, maintenance, or removal of their facilities.

- c. To inform SGVCOG in writing within fifteen (15) days after receipt of each set of plans, studies, specifications, and/or cost estimates from SGVCOG, if any of the materials are incomplete or if additional information is necessary in order to facilitate PERMITTEE's review of the materials.
- d. To review and provide to SGVCOG any comments and suggestions to, or required approvals/disapprovals of each set of plans, studies, specifications, and/or cost estimates submitted to PERMITTEE within thirty (30) days after receipt of the complete materials.
- e. That the plans shall be considered complete and acceptable by PERMITTEES when the plans involving PROJECT have been reviewed and approved by the PERMITTEE's City Engineer, or his/her designated agent. Receipt by SGVCOG of PROJECT plans signed by PERMITTEE's City Engineer or his/her designated agent shall constitute PERMITTEE's approval of said plans.
- f. That the funds provided by PERMITTEES for this work shall be eligible for such expenditures.
- g. Payment. To pay the SGVCOG for its proportional share of the estimated cost for managing the consultant(s) and administering this AGREEMENT as shown in Exhibit A, within sixty (60) days of receipt of the invoice from SGVCOG. The cost estimates presented in Exhibit A have been agreed upon by the PARTIES and are subject to changes in the LRS pursuant to new REGIONAL BOARD requirements and/or unforeseen challenges in the field. Any such changes proposed to the PERMITTEES' proportional share are subject to funding appropriation and will require written approval of the PERMITTEES as explained in section 6(d).
- h. Documentation. To make a good faith effort to cooperate with one another to achieve the purposes of this AGREEMENT by providing all requested information and documentation, in their possession and available for release to the SGVCOG and its consultant(s), that are deemed necessary by the PARTIES to prepare the design plans.
- i. Access. Each PERMITTEE will allow reasonable access and entry to the consultant, on an as needed basis during the term of this AGREEMENT, to the PERMITTEES' FACILITIES to achieve the purposes of this AGREEMENT, provided, however, that prior to entering any of the PERMITTEE'S FACILITIES, the consultant shall obtain all necessary permits and approvals, including executing a Right-of-Entry Agreement as may be necessary, and provide written notice 72 hours in advance of entry to the applicable PERMITTEE. Permittees shall provide any required permits at no cost to the SGVCOG or its consultants.

## Section 8. Indemnification

- a. Each PARTY, which includes the SGVCOG, shall indemnify, defend, and hold harmless each other PARTY, including their special districts, elected and appointed officers, employees, agents, attorneys, and designated volunteers from and against any and all liability, including, but not limited to demands, claims, actions, fees, costs, and expenses (including reasonable attorney's and expert witness fees), arising from or connected with, and in relative proportion to, its own negligence or willful misconduct under this AGREEMENT; provided, however, that no PARTY shall indemnify another PARTY for the latter PARTY'S own negligence or willful misconduct.
- b. The PARTIES agree that any liability borne by or imposed upon any PARTY or PARTIES hereto, arising out of this AGREEMENT and that is not caused by or attributable to the negligence or willful misconduct of any PARTY hereto, shall be fully borne by all the PERMITTEES in accordance with their respective pro rata cost shares, as set forth in Exhibit A.
- c. If any PERMITTEE pays in excess of its pro rata share in satisfaction of any liability described in subsection b. above, such PERMITTEE shall be entitled to contribution from each of the other PERMITTEES; provided, however, that the right of contribution is limited to the amount paid in excess of the PERMITTEE's pro rata share and provided further that no PERMITTEE may be compelled to make contribution beyond its own pro rata share of the entire liability; and provided further that no PERMITTEE shall indemnify another PERMITTEE for the latter PERMITTEE's own negligence or willful misconduct.
- d. To the maximum extent permitted by law, the SGVCOG shall require any contractor retained pursuant to this AGREEMENT to agree to indemnify, defend, and hold harmless each PARTY, which includes the SGVCOG, their special districts, elected and appointed officers, employees, attorneys, agents, and designated volunteers from and against any and all liability, including but not limited to demands, claims, actions, fees, costs, and expenses (including attorney and expert fees), arising from or connected with the contractor's performance of its agreement with the SGVCOG. In addition, the SGVCOG shall require any such contractor to carry, maintain, and keep in full force and effect an insurance policy or policies, and each PARTY, its elected and appointed officers, employees, attorneys, agents and designated volunteers shall be named as additional insureds on the policy(ies) with respect to liabilities arising out of the contractor's work. These requirements will also apply to any subcontractors hired by the contractor.

## Section 9. Termination and Withdrawal

1. This AGREEMENT may be terminated upon the express written agreement of all PARTIES. If this AGREEMENT is terminated, then all PARTIES must agree on the equitable redistribution of remaining funds deposited, if there are any, or payment of invoices due at the time of termination. Completed work shall be owned by the PARTY or PARTIES who fund the completion of such work. Rights



to uncompleted work by the consultant still under contract will be held by the PARTY or PARTIES who fund the completion of such work.

2. If a PARTY fails to substantially comply with any of the terms or conditions of this AGREEMENT, then that PARTY shall forfeit its rights to work completed through this AGREEMENT, but no such forfeiture shall occur unless and until the defaulting PARTY has first been given notice of its default and a reasonable opportunity to cure the alleged default.
3. SGVCOG will notify all PARTIES in writing of any PARTY failing to cure an alleged default in compliance with the terms or conditions of this AGREEMENT. The non-delinquent PARTIES will determine the next course of action. The remaining cost will be distributed based on the existing cost allocation formula in Exhibit A. If the increase is more than the 10 percent contingency, an amendment to this AGREEMENT must be executed to reflect the change in the PARTIES' cost share.
4. If a PARTY wishes to withdraw from this AGREEMENT for any reason, that PARTY must give the other PARTIES and the REGIONAL BOARD prior written notice thereof. The withdrawing PARTY shall be responsible for its entire share of the LRS development costs shown in Exhibit A. The effective date of withdrawal shall be the 6th day after SGVCOG receives written notice of the PARTY'S intent to withdraw. Should any PARTY withdraw from this AGREEMENT, the remaining PARTIES' cost share allocation shall be adjusted in accordance with the cost allocation formula in Exhibit A.

#### Section 10. General Provisions

- a. Notices. Any notices, bills, invoices, or reports relating to this AGREEMENT, and any request, demand, statement, or other communication required or permitted hereunder shall be in writing and shall be delivered to the representatives of the PARTIES at the addresses set forth in Exhibit B attached hereto and incorporated herein by reference. The PARTIES shall promptly notify each other of any change of contact information, including personnel changes, provided in Exhibit B. Written notice shall include notice delivered via e-mail or fax. A notice shall be deemed to have been received on (a) the date of delivery, if delivered by hand during regular business hours, or by confirmed facsimile or by e-mail; or (b) on the third (3rd) business day following mailing by registered or certified mail (return receipt requested) to the addresses set forth in Exhibit B.
- b. Administration. For the purposes of this AGREEMENT, the PARTIES hereby designate as their respective PARTY representatives the persons named in Exhibit B. The designated PARTY representatives, or their respective designees, shall administer the terms and conditions of this AGREEMENT on behalf of their respective PARTY. Each of the persons signing below on behalf of a PARTY represents and warrants that he or she is authorized to sign this AGREEMENT on behalf of such PARTY.

- c. Relationship of the PARTIES. The PARTIES are, and shall at all times remain as to each other, wholly independent entities. No PARTY to this AGREEMENT shall have power to incur any debt, obligation, or liability on behalf of any other PARTY unless expressly provided to the contrary by this AGREEMENT. No employee, agent, or officer of a PARTY shall be deemed for any purpose whatsoever to be an agent, employee, or officer of another PARTY.
- d. Binding Effect. This AGREEMENT shall be binding upon, and shall be to the benefit of the respective successors, heirs, and assigns of each PARTY; provided, however, no PARTY may assign its respective rights or obligations under this AGREEMENT without prior written consent of the other PARTIES.
- e. Amendment. The terms and provisions of this AGREEMENT may not be amended, modified, or waived, except by an instrument in writing signed by all non-delinquent PARTIES. For purposes of this AGREEMENT, a PARTY shall be considered delinquent if that PARTY fails to timely pay an invoice as required by Section 7(a) or withdraws pursuant to Section 9(d).
- f. Law to Govern. This AGREEMENT is governed by, interpreted under, and construed and enforced in accordance with the laws of the State of California.
- g. Severability. If any provision of this AGREEMENT is determined by any court to be invalid, illegal, or unenforceable to any extent, then the remainder of this AGREEMENT will not be affected, and this AGREEMENT will be construed as if the invalid, illegal, or unenforceable provision had never been contained in this AGREEMENT.
- h. Entire Agreement. This AGREEMENT constitutes the entire agreement of the PARTIES with respect to the subject matter hereof.
- i. Waiver. Waiver by any PARTY to this AGREEMENT of any term, condition, or covenant of this AGREEMENT shall not constitute a waiver of any other term, condition, or covenant. Waiver by any PARTY to any breach of the provisions of this AGREEMENT shall not constitute a waiver of any other provision, nor a waiver of any subsequent breach or violation of any provision of this AGREEMENT.
- j. Counterparts. This AGREEMENT may be executed in any number of counterparts, each of which shall be an original, but all of which taken together shall constitute one and the same instrument, provided, however, that such counterparts shall have been delivered to all PARTIES to this AGREEMENT.
- k. All PARTIES have been represented by counsel in the preparation and negotiation of this AGREEMENT. Accordingly, this AGREEMENT shall be construed according to its fair language. Any ambiguities shall be resolved in a collaborative

manner by the PARTIES and shall be rectified by amending this AGREEMENT as described in section 10(e).

IN WITNESS WHEREOF, the PARTIES hereto have caused this AGREEMENT to be executed by their duly authorized representatives and affixed as of the date of signature of the PARTIES:

COUNTY OF LOS ANGELES

By   
MARK PESTRELLA, Director of Public  
Works

9/6/18  
Date

APPROVED AS TO FORM:

MARY C. WICKHAM  
County Counsel

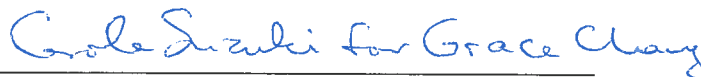
By   
Deputy

5-22-18  
Date

**CITY OF ALHAMBRA**

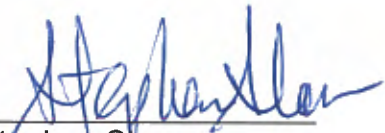
By   
Stephen Sham  
Mayor

5/14/18  
Date

APPROVED AS TO FORM:

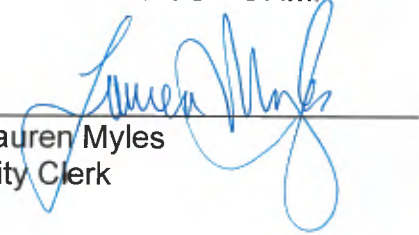
By   
Lauren Myles  
City Clerk

APPROVED AS TO FORM:

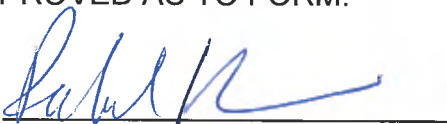
By   
Joseph M. Montes, Esq.  
City Attorney

CITY OF MONTEREY PARK

By   
Ron Bow  
City Manager

Date 6/12/18

APPROVED AS TO FORM:

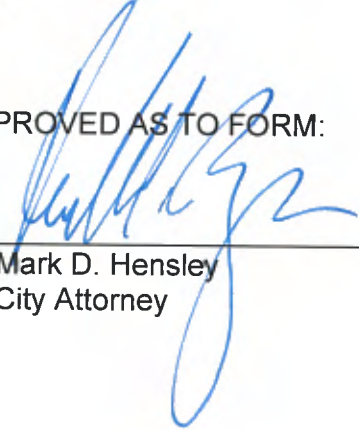
By   
Mark D. Hensley  
City Attorney

CITY OF PASADENA

By   
Steve Mermell JULIE A. GUTIERREZ  
City Manager Assistant City Manager

8-12-18  
Date

APPROVED AS TO CONTENT:

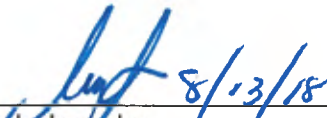
By  8/13/18  
Mark Jonsky  
City Clerk

APPROVED AS TO FORM:

By   
Brad L. Fuller  
Assistant City Attorney

CITY OF ROSEMEAD

By   
Gloria Molleda  
City Manager

5/15/18  
Date

APPROVED AS TO CONTENT:

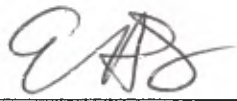
By   
Ericka Hernandez  
City Clerk

APPROVED AS TO FORM:

By   
Rachel Richman  
City Attorney  
Burke, Williams & Sorensen, LLP



CITY OF SAN GABRIEL

By   
Mark Lazzaretto,  
City Manager

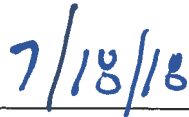
  
Date

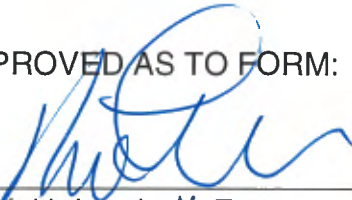
APPROVED AS TO FORM:  
By   
Keith Lemieux, Esq.  
City Attorney

**CITY OF SAN MARINO**

By   
Steven W. Huang, DDS  
Mayor

01-04-19  
Date

APPROVED AS TO CONTENT:

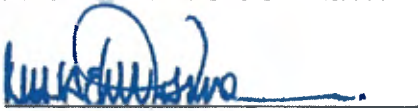
By   
Michael Throne, PE  
Parks & Public Works Director/City Engineer

APPROVED AS TO FORM:

By   
Steven Flower, Esq.  
City Attorney

CITY OF SOUTH PASADENA

By   
Stephanie DeWolfe  
City Manager

07/18/2018  
Date

APPROVED AS TO CONTENT:

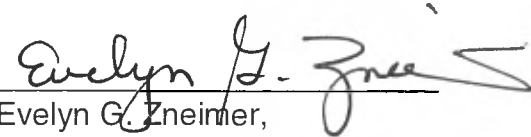
By   
Evelyn G. Zneimer,  
City Clerk

APPROVED AS TO FORM:

By   
Teresa L. Highsmith, Esq.  
City Attorney

CITY OF TEMPLE CITY

By   
William Man  
Mayor

6-6-18  
Date

ATTEST:

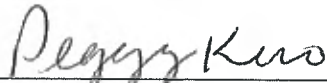
By   
Peggy Kuo  
City Clerk 6-6-18

APPROVED AS TO FORM:

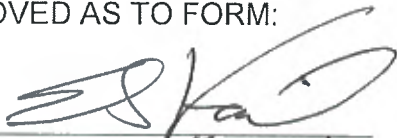
By   
~~Gregory Murphy~~ ERIC S. VAIL  
City Attorney

**SAN GABRIEL VALLEY COUNCIL OF GOVERNMENTS**

By   
Marisa Creter  
Executive Director

Date 7/16/18

APPROVED AS TO FORM:

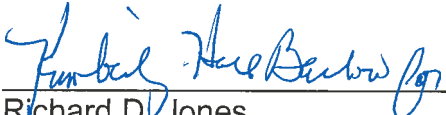
By   
Richard D. Jones  
Counsel for the SGVCOG

## EXHIBIT A

### Rio Hondo and Tributaries Funding Contributions for LRS Implementation

**Table 1. Not-To-Exceed Party Cost-Share**

Jurisdiction	Total	Table 2	Table 3	Table 4
Alhambra	\$89,938	\$85,362	\$1,633	\$2,943
Monterey Park	\$51,895	\$49,274	\$934	\$1,687
Pasadena	\$860,530	\$816,451	\$15,717	\$28,362
Rosemead	\$13,179	\$12,492	\$246	\$441
San Gabriel	\$16,800	\$15,962	\$299	\$539
San Marino	\$256,417	\$243,061	\$4,761	\$8,595
South Pasadena	\$21,218	\$20,126	\$389	\$703
Temple City	\$243,863	\$233,920	\$3,545	\$6,398
County	\$295,160	\$312,352	(-\$27,524)	\$10,332
<b>Total</b>	<b>\$1,849,000</b>	<b>\$1,789,000</b>	<b>\$0</b>	<b>\$60,000</b>

Table 2: Party's Design Cost Per Waterbody  
 Table 3: Rio Hondo LRS Addendum Report  
 Table 4: SGVCOG Admin Fee

**EXHIBIT A**

Rio Hondo and Tributaries  
Funding Contributions for LRS Implementation

**Table 2. Party's Design Cost Per Waterbody**

Jurisdiction	Total	Alhambra Wash			Eaton Wash			Rubio Wash		
		Drainage Area (ac)	Percentage	Cost	Drainage Area (ac)	Percentage	Cost	Drainage Area (ac)	Percentage	Cost
Alhambra	\$85,362	751.10	12.3%	\$85,362	0	0	0	0	0	0
Monterey Park	\$49,274	430.37	7.1%	\$49,274	0	0	0	0	0	0
Pasadena	\$816,451	2,845.42	46.8%	\$324,792	1,104.56	29.1%	\$158,304	3,287.40	60.5%	\$333,355
Rosemead	\$12,492	112.65	1.8%	\$12,492	0	0	0	0	0	0
San Gabriel	\$15,962	137.59	2.3%	\$15,962	0	0	0	0	0	0
San Marino	\$243,061	1,368.11	22.5%	\$156,150	80.10	2.1%	\$11,424	745.00	13.7%	\$75,487
South Pasadena	\$20,126	179.51	2.9%	\$20,126	0	0	0	0	0	0
Temple City	\$233,920	0	0	0	1,632.35	43.0%	\$233,920	0	0	0
County	\$312,352	259.27	4.3%	\$29,842	977.03	25.8%	\$140,352	1,400.30	25.8%	\$142,158
<b>TOTAL</b>	<b>\$1,789,000</b>	<b>6,084.02</b>		<b>\$694,000</b>	<b>3,794.04</b>		<b>\$544,000</b>	<b>5,432.70</b>		<b>\$551,000</b>

## EXHIBIT A

### Rio Hondo and Tributaries Funding Contributions for LRS Implementation

**Table 3. Rio Hondo LRS Addendum Report<sup>1</sup>**

Jurisdiction	Total	Rio Hondo LRS Addendum Report		
		Drainage Area (ac) <sup>2</sup>	Percentage	Cost
Alhambra	\$1,633	751.10	4.91%	\$1,633
Monterey Park	\$934	430.37	2.81%	\$934
Pasadena	\$15,717	7,237.38	47.27%	\$15,717
Rosemead	\$246	112.65	0.74%	\$246
San Gabriel	\$299	137.59	0.90%	\$299
San Marino	\$4,761	2,193.21	14.32%	\$4,761
South Pasadena	\$389	179.51	1.17%	\$389
Temple City	\$3,545	1,632.35	10.66%	\$3,545
County	\$5,726	2,636.60	17.22%	\$5,726
<b>TOTAL</b>	<b>\$33,250</b>	<b>15,310.76</b>	<b>100%</b>	<b>\$33,250</b>

1. County's credit is \$27,524 (\$33,250-\$5,726)

2. Drainage Area = Drainage areas from Alhambra Wash + Eaton Wash + Rubio Wash

**Table 4. SGVCOG Admin Fee<sup>1</sup>**

Jurisdiction	Total	Drainage Area (ac)	Percentage
Alhambra	\$2,943	751.10	4.91%
Monterey Park	\$1,687	430.37	2.81%
Pasadena	\$28,362	7,237.38	47.27%
Rosemead	\$441	112.65	0.74%
San Gabriel	\$539	137.59	0.90%
San Marino	\$8,595	2,193.21	14.32%
South Pasadena	\$703	179.51	1.17%
Temple City	\$6,398	1,632.35	10.66%
County	\$10,332	2,636.60	17.22%
<b>Total</b>	<b>\$60,000</b>	<b>15,310.76</b>	<b>100%</b>

1. SGVCOG Admin Fee = \$60,000



## EXHIBIT B

### Rio Hondo River and Tributaries Responsible Agency Representatives

AGENCY ADDRESS	AGENCY CONTACT
County of Los Angeles Department of Public Works Stormwater Quality Division, 11th Floor 900 South Fremont Avenue Alhambra, CA 91803	Paul Alva Email: palva@dpw.lacounty.gov Phone: (626) 458-4325 Fax: (626) 457-1526
City of Alhambra 111 South First Street Alhambra, CA 91801	David Dolphin Email: ddolphin@cityofalhambra.org Phone: (626) 300-1571 Fax: (626) 282-5833
City of Monterey Park 320 West Newmark Avenue Monterey Park, CA 91754	Bonnie Tam Email: btam@montereypark.ca.gov Phone: (626) 307-1383 Fax: (626) 307-2500
City of Pasadena P.O. Box 7115 Pasadena, CA 91109	Sean Singletary Email: ssingletary@cityofpasadena.net Phone: (626) 744-4273 Fax: (626) 744-3823
City of Rosemead 8838 East Valley Boulevard Rosemead, CA 91770	Elroy Kiepke Email: ekiepke@willdan.com Phone: (562) 908-6278 Fax: (626) 307-9218
City of San Gabriel 425 South Mission Avenue San Gabriel, CA 91776	Daren Grilley Email: dgrilley@sgch.org Phone: (626) 308-2806 Fax: (626) 458-2830
City of San Marino 2200 Huntington Drive San Marino, CA 91108	Marcella Marlowe Email: MMarlowe@cityofsanmarino.org Phone: 626 300-0700 Fax:

## EXHIBIT B

### Rio Hondo River and Tributaries Responsible Agency Representatives

<p>City of South Pasadena 1414 Mission Street South Pasadena, CA 91030</p>	<p>Shin Furukawa Email: <a href="mailto:sfurukawa@ci.south-pasadena.ca.us">sfurukawa@ci.south-pasadena.ca.us</a> Phone: (626) 403-7246 Fax: (626) 403-7241</p>
<p>City of Temple City 9701 Las Tunas Drive Temple City, CA 91780</p>	<p>Andrew Coyne Email: <a href="mailto:acoyne@templecity.us">acoyne@templecity.us</a> Phone: Fax:</p>
<p>San Gabriel Valley Council of Governments 1000 S. Fremont Ave. Unit 42 Bldg A10-N, Suite 10210 Alhambra, CA 91803</p>	<p>Marisa Creter Email: <a href="mailto:mcreter@sgvcog.org">mcreter@sgvcog.org</a> Phone: (626) 457-1800 Fax: (626) 457-1285</p>



---

**ATTACHMENTS FOR SECTION 8.1:**

**ENVIRONMENTAL DOCUMENTS AND  
PERMITS**

---



---

**ATTACHMENTS FOR SECTION 8.2:**

**VECTOR MINIMIZATION**

---

# **San Gabriel Valley Council of Governments Load Reduction Strategy Projects Vector Minimization Plan**

**Prepared for:**



San Gabriel Valley Council of Governments  
1000 Fremont Ave #42, Alhambra, CA 91803  
TEL (626) 457-1800

**Prepared by:**



1561 E. Orangethorpe Avenue, Suite 240  
Fullerton, California, 92831

TEL (714) 526-7500 | FAX (714) 526-7004 | [www.cwecorp.com](http://www.cwecorp.com)

**October 2020**

# 1. Introduction

Management of mosquitoes and other vectors in stormwater management structures, such as flood control basins and Best Management Practices (BMPs), is critical for protecting public health. With careful planning, such structures can be designed, built, operated, and maintained in a manner that minimizes opportunities for the proliferation of vectors. This Vector Minimization Plan has been prepared based on the *Checklist for Minimizing Vector Production in Stormwater Management Structures* developed by the State of California Health and Human Services Agency (<https://www.cdph.ca.gov/Programs/CID/DCDC/CDPH%20Document%20Library/ChecklistforVectorPreventioninBMPs.pdf>). The checklist provides action items intended to lessen the short and long-term potential for vector production in stormwater management structures while reducing dependence on pesticides to the maximum extent possible.

The checklist items are incorporated into this Plan. Narrative discussions are included as necessary to clarify applicability. The Plan is broken into sections for wet and dry systems, consistent with the referenced checklist. Each section identifies what project components fall into each category. The Project does not include any permanent water features or wetlands; therefore, associated portions of the checklist are not included in this Plan.

# 2. Project Overview

This Vector Minimization Plan is prepared in association with the Load Reduction Strategy Projects for the Rio Hondo River and Tributaries (Project) being implemented by San Gabriel Valley Council of Governments (SGVCOG), on behalf of the County of Los Angeles (County) and the Cities of Alhambra, Monterey Park, Pasadena, Rosemead, San Gabriel, San Marino, South Pasadena, and Temple City. The Project will improve water quality by capturing flows from the cities listed above within the Project's drainage area. The goal of the Project is to reduce the quantity of pollutants reaching the Rio Hondo through the discharge of dry-weather runoff. The Project will treat diverted dry-weather runoff from Alhambra Wash, Eaton Wash, and Rubio Wash and discharge the treated runoff back into the channels. The Project is being implemented in response to the Los Angeles River (LAR) Bacteria Total Maximum Daily Load (TMDL).

# 3. Dry Systems

Dry systems are defined as any structure designed to drain completely following capture and/or treatment of runoff. Examples identified in the checklist include flood control basins, extended detention basins, infiltration basins and trenches, Austin sand filters, swales and strips, drain inlet inserts, and/or linear-radial gross solids removal devices. It is recommended that dry systems discharge all captured water in four (4) days or less to address vector concerns.

The following dry systems are included as part of the Project:

- Grated inlet – partially dry during dry-weather season and considered quasi dry system. During a storm event, the pump will shut down. During this time, the water will back up into the diversion pipe and grated inlet, sit for a minimum of 72 hours, and then it will be pumped to the treatment system. It is anticipated that the water will be flowing in and around the inlet during the 72 hours following a storm event (no truly standing/still water).

Water will not be standing for more than four (4) days. The grated inlet will be filled and turbulent water will bypass the system. Once the storm event is over, the pump will turn back on and pump out accumulated water in the grated inlet. Turbulent channel waters will make a hostile environmental for vectors.

### 3.1 Dry System Checklist

Dry systems will drain completely within four (4) days, avoiding vector concerns. The checklist below is based on the *Checklist for Minimizing Vector Production in Stormwater Management Structures* for dry systems. The checklist is completed based on the Project and narrative is included, as necessary, to provide additional Project information and clarification.

<input checked="" type="checkbox"/>	Is the structure designed to discharge all captured water in four (4) days or less?
<b>Additional Clarification/Response (if necessary):</b> As described above, water will not be standing (still) for more than four (4) days.	

<input checked="" type="checkbox"/>	Has every effort been made to trace and eliminate persistent non-stormwater flows (e.g. irrigation runoff) that may enter the system and jeopardize non-chemical vector control efforts?
<b>Additional Clarification/Response (if necessary):</b> The channels (Alhambra Wash, Eaton Wash, and Rubio Wash) captures dry-weather flows from an expansive region and sources may include irrigation runoff.	

<input checked="" type="checkbox"/>	Has groundwater depth been carefully evaluated to ensure that the structure will not be permanently or seasonally flooded (i.e. is the base of the basin higher than the local groundwater table)?
<b>Additional Clarification/Response (if necessary):</b> Geotechnical explorations in each of the Project sites have not encountered groundwater at a depth that will impact proposed infrastructure. Historical Well Measurement Data indicates groundwater elevations vary at each site from 25 – 50 feet below ground surface. The dry system components will not be placed deep enough to encounter groundwater.	

<input checked="" type="checkbox"/>	Does the design provide an adequate slope between the inlets and outlets, with special attention given to ensure corners are above grade?
<b>Additional Clarification/Response (if necessary):</b> True for gravity pipe conveyances.	

<input checked="" type="checkbox"/>	Has soil been compacted adequately during grading to minimize subsidence, which can result in pools of standing water?
<b>Additional Clarification/Response (if necessary):</b> Adequate compaction required in the Project specifications.	

<input checked="" type="checkbox"/>	Does the design slope take into consideration the inevitable accumulation of sediment and debris between maintenance periods that can result in standing water, especially in and around the inlet?
<b>Additional Clarification/Response (if necessary):</b> Slope is sufficient. Storm flows will help clear accumulated sediment and debris in inlet structure.	



<input type="checkbox"/>	Does the design minimize the use of features that increase the potential for standing water, such as loose riprap and concrete curbs?
<b>Additional Clarification/Response (if necessary):</b> Not applicable (no new rip rap or surface drainage features).	

<input type="checkbox"/>	Does the structure include a concrete or earthen low-flow channel to concentrate (i.e. minimize available surface area) and direct non-stormwater flows to the outlet?
<b>Additional Clarification/Response (if necessary):</b> Not applicable (no low-flow channels).	

<input checked="" type="checkbox"/>	Is the distribution piping sloped adequately and smooth (not corrugated) on the inside to prevent standing water?
<b>Additional Clarification/Response (if necessary):</b> Diversion pipe will be sloped and smooth.	

<input type="checkbox"/>	Are the inlet structures and energy dissipaters designed and sloped sufficiently to prevent scour depressions?
<b>Additional Clarification/Response (if necessary):</b> Not applicable (no energy dissipater structures and scour is not anticipated, as improvements are mostly concrete).	

<input checked="" type="checkbox"/>	Are the outlets designed with debris screens or other features that reduce the potential for clogging?
<b>Additional Clarification/Response (if necessary):</b> Inlet is grated to prevent trash and debris from entering the diversion system and downstream components.	

<input checked="" type="checkbox"/>	Is the structure designed with safe and sufficient access for inspection, maintenance, and/or vector control activities when needed?
<b>Additional Clarification/Response (if necessary):</b> A manhole is proposed within the pump well (wet system).	

<input checked="" type="checkbox"/>	Does the operation and maintenance plan include a minimum of quarterly inspections to ensure that vegetation overgrowth, sediment accumulation, or other factors have not created areas of standing water?
<b>Additional Clarification/Response (if necessary):</b> Diversion structure will be inspected at least twice a year, before and after the wet season, for clogging over the grate and debris buildup. Sediment and debris accumulation will be removed based on inspection findings.	

<input type="checkbox"/>	Does the operation and maintenance plan include a minimum annual maintenance to remove vegetation overgrowth, remove sediment and debris accumulation, and otherwise return the structure to "as-designed" conditions?
<b>Additional Clarification/Response (if necessary):</b> Not applicable for dry system (no vegetation within stormwater management system).	





<input type="checkbox"/> Is signage provided and clearly visible with minimum information indicating the type of structure (e.g. extended detention basin), ownership, and contact information?
<b>Additional Clarification/Response (if necessary):</b> Not applicable

## 4. Wet Systems

Wet systems are defined as any structure designed with features such as sumps, vaults, and/or basins that hold water permanently, or longer than four (4) days. Examples identified in the checklist include open catch basins, concrete retention basins, Delaware sand filters, and a variety of belowground proprietary devices. It is recommended that wet systems are designed to deny mosquito access to standing water by using covers, screens, and/or other barriers.

The following wet system is included as part of the Project:

- Pump station in access road or property next to the channel (standing/still water not anticipated, as dry-weather flow is anticipated on a semi-continuous basis and flows will still enter the pump well during wet-weather flows when the pump will not turn on)
- Valve vault/flow meter vault may be used as part of the diversion and control system (pending final design)

The wet system will include covers, screens, and other barriers to deny access to mosquitos/vectors. This allows the Project to address vector concerns related to the identified component.

### 4.1 Wet System Checklist

Wet systems will include covers, screens, and other barriers to prevent mosquitos/vectors from entering the systems with standing water, allowing the Project to avoid vector concerns. The checklist below is based on the *Checklist for Minimizing Vector Production in Stormwater Management Structures* for wet systems. The checklist is completed based on the Project and narrative is included, as necessary, to provide additional Project information and clarification.

<input checked="" type="checkbox"/> Have sumps, vaults, or basins that hold water permanently, or longer than 4 days, been completely or partially sealed against adult mosquito entry?
<b>Additional Clarification/Response (if necessary):</b> The system is sealed and a mosquito screen/barrier will be implemented at the manhole access point for the pump well and any other vaults included as part of the Project.

<input checked="" type="checkbox"/> If used, are covers tight fitting, with gaps or holes of no greater than 1/16" (2 mm)?
<b>Additional Clarification/Response (if necessary):</b> See response above about the use of screens/barriers.

<input checked="" type="checkbox"/> If used, are aluminum or nylon screens for sealing small openings secured with gaps or holes of no greater than 1/16" (2 mm)?
<b>Additional Clarification/Response (if necessary):</b> Design will require the gap to be minimized.

<input checked="" type="checkbox"/> If cast iron manhole covers are used, are pick holes sealed or is a mosquito-proof insert provided below?
<b>Additional Clarification/Response (if necessary):</b> See response above about the use of screens/barriers.

<input type="checkbox"/> Where feasible, are the inlet and/or outlet conveyance pipes submerged to prevent adult mosquito entry into the main water storage area?
<b>Additional Clarification/Response (if necessary):</b> Not applicable (inlets into the pump station will not always be submerged, while semi-continuous flow is expected).

<input type="checkbox"/> Where feasible, are conveyance pipes fitted with flapper valves, collapsible fabric tubes, or other barriers to prevent adult mosquito entry into the main water storage area?
<b>Additional Clarification/Response (if necessary):</b> Not applicable.

<input checked="" type="checkbox"/> Is the structure designed with safe and sufficient access to permanent water areas for inspection, maintenance, and/or vector control activities when needed?
<b>Additional Clarification/Response (if necessary):</b> The pump well and any vaults will have accessibility for inspection and maintenance.

<input checked="" type="checkbox"/> Does the operation and maintenance plan include a minimum of quarterly inspections to ensure that barriers to mosquito entry are intact and in place as designed?
<b>Additional Clarification/Response (if necessary):</b> Operation and maintenance plan will include quarterly inspections.

<input checked="" type="checkbox"/> Where possible, is signage provided with minimum information indicating type of structure (e.g. CDS™), ownership, and contact information?
<b>Additional Clarification/Response (if necessary):</b> Manhole/vault covers will include some information pertaining to equipment and/or the respective City/maintaining agency.

## 5. Vector Minimization Summary

In summary, the following vector minimization strategies are included as part of the Project:

- The pump shutoff during storm events will cause the diversion pipe and grated inlet to fill with turbulent water (not conducive for mosquito breeding)
- Grated inlet will be inspected twice a year for clogging and debris buildup
- Mosquito screens/barriers will be included in pump well manhole/access and any vaults





---

**ATTACHMENTS FOR SECTION 8.6:**

**TECHNICAL REPORTS**

---

# SAN GABRIEL VALLEY COUNCIL OF GOVERNMENTS LOAD REDUCTION STRATEGIES PROJECT

## LEGEND

--- E --- E --- E --- E ---	EXISTING ELECTRICAL LINE
--- G --- G --- G --- G ---	EXISTING GAS LINE
--- O --- O --- O --- O ---	EXISTING OIL LINE
--- RW --- RW --- RW --- RW ---	EXISTING RECLAIMED WATER LINE
--- SS --- SS --- SS --- SS ---	EXISTING SANITARY SEWER LINE
--- SD --- SD --- SD --- SD ---	EXISTING STORM DRAIN LINE
--- W --- W --- W --- W ---	EXISTING WATER LINE
--- X --- X --- X --- X ---	EXISTING FENCE
-----	CITY BOUNDARY
-----	CENTERLINE
-----	PROPERTY LINE

## ABBREVIATIONS

CL	CENTERLINE
DI	DUCTILE IRON
EX.	EXISTING
INV	INVERT
MH	MANHOLE
PROP.	PROPOSED
R/W	RIGHT-OF-WAY
RCP	REINFORCED CONCRETE PIPE
SD	STORM DRAIN
SS	SANITARY SEWER
SSMH	SANITARY SEWER MANHOLE
ST	STEEL
STL	STEEL
VCP	VITRIFIED CLAY PIPE

UTILITY COMPANY CONTACTS		
COMPANY	CONTACT	PHONE NO.
CITY OF EL MONTE	JIMMY CHUNG	(626) 580-2087
CITY OF ROSEMEAD	LUCIEN LEBLANC	(626) 569-2150
GOLDEN STATE WATER COMPANY	KYLE SNAY	(909) 592-4271 (EXT. 1403)
LOS ANGELES COUNTY SANITATION DISTRICT	CHRISTINE GURGA	(562) 908-4288 (EXT. 1205)
METROPOLITAN WATER DISTRICT	CLAY ANDERSON	(213) 217-6717
SAN GABRIEL VALLEY WATER COMPANY	VINCENT CHEN	(909) 201-7385
SOUTHERN CALIFORNIA EDISON	SCE PLANNING SUPERVISOR	(323) 720-5263
SOUTHERN CALIFORNIA GAS	WILTON SHEN	(714) 634-5026
TPX COMMUNICATIONS	MARK DENNING	(949) 864-0296 (949) 547-6455

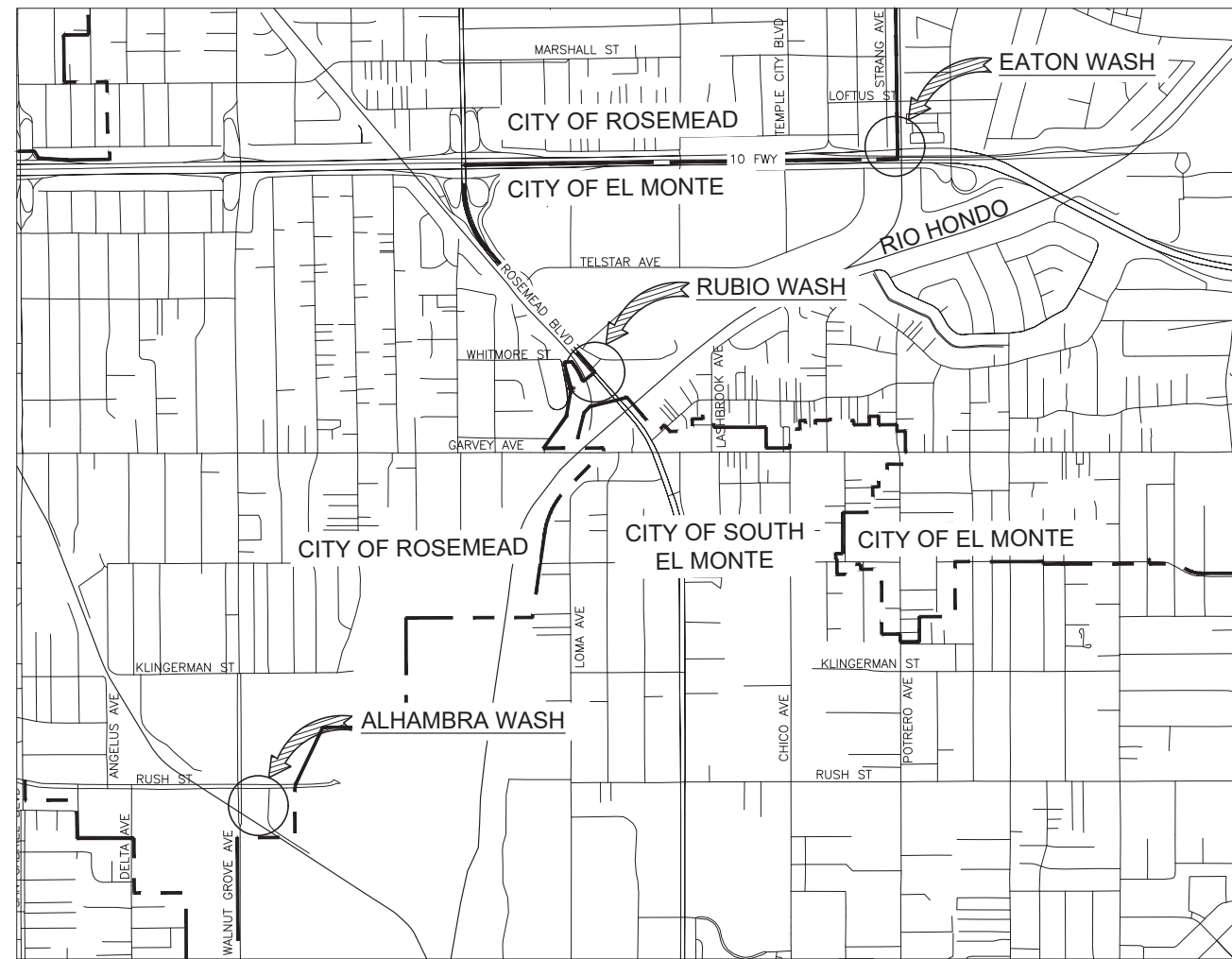

SHEET INDEX		
SHEET NO.	DRAWING NO.	SHEET TITLE
1	T-01	TITLE SHEET
2	C-01	GENERAL NOTES
3	C-02	ALHAMBRA WASH DIVERSION PLAN
4	C-03	EATON WASH DIVERSION PLAN
5	C-04	RUBIO WASH DIVERSION PLAN
6	C-05	DETAILS
7	C-06	TREATMENT SYSTEM
8	C-07	ALHAMBRA WASH DIVERSION PUMP
9	C-08	EATON WASH DIVERSION PUMP
10	C-09	RUBIO WASH DIVERSION PUMP

## BASIS OF BEARINGS

**ALHAMBRA WASH**  
THE BASIS OF BEARING FOR THIS SURVEY IS, CALIFORNIA COORDINATE SYSTEM, ZONE 5, NAD 83 (EPOCH 2010.0) AS DETERMINED LOCALLY BY A LINE BETWEEN CONTINUOUS OPERATING REFERENCE STATIONS (CORS) AND CL INT. RUSH ST & WALNUT GROVE AVE

**EATON WASH**  
THE BASIS OF BEARINGS FOR THIS SURVEY IS THE CALIFORNIA COORDINATE SYSTEM, ZONE 5, NAD 83 (EPOCH 2010.0) AS DETERMINED LOCALLY BY A LINE BETWEEN CONTINUOUS OPERATING REFERENCE STATIONS (CORS) AND CL INT. BALDWIN AVE & LUTUS DR

**RUBIO WASH**  
THE BASIS OF BEARINGS FOR THIS SURVEY IS THE CALIFORNIA COORDINATE SYSTEM, ZONE 5, NAD 83 (EPOCH 2010.0) AS DETERMINED LOCALLY BY A LINE BETWEEN CONTINUOUS OPERATING REFERENCE STATIONS (CORS) AND CL INT. GARVEY AVE & ROSEMEAD BL.

## BENCHMARK

**ALHAMBRA WASH**  
BENCHMARK - SY10697 ELEV = 271.638 NAVD1988 (2005 ADJ)  
LACO BM TAG IN E CB 6.5FT N/O BCR @ NE COR SAN GABRIEL BLVD & RUSH ST

**EATON WASH**  
BENCHMARK - MG3247 ELEV = 264.451 NAVD1988 (2005 ADJ)  
RDBM TAG IN S CB 34FT W/O BCR @ SW COR MARSHALL BLVD & TEMPLE CITY

**RUBIO WASH**  
BENCHMARK - MG1450 ELEV = 248.744 NAVD1988 (2005 ADJ)  
L&BN IN E CB 5FT S/O BCR @ SE COR ROSEMEAD BLVD & WHITMORE AVE

## VERTICAL DATUM

NORTH AMERICAN VERTICAL DATUM OF 1988.

NO.	DATE	REVISIONS
6		
5		
4		
3		
2		
1		

DESIGNED BY: TT	DATE: JUNE 2020
CHECKED BY: KH	DATE: JUNE 2020

SEAL

PREPARED BY:  
**CWE**  
1561 E. ORANGETHORPE AVE.  
SUITE 240  
FULLERTON, CA 92831  
TEL (714) 526-7500  
www.cwecorp.com

PROJECT TITLE  
**SAN GABRIEL VALLEY COUNCIL OF GOVERNMENTS  
LOAD REDUCTION STRATEGY PROJECT**

SHEET TITLE  
**TITLE SHEET**

PROJECT NO.  
**18301**

DRWG NO. **T-01**

SHEET **1**

OF **10**

**PRELIMINARY DESIGN  
NOT FOR CONSTRUCTION**

LOCATION MAP  
SCALE: 1" = 1000'



**GENERAL NOTES:**

1. ALL WORK SHALL BE COMPLETED IN ACCORDANCE WITH THE CONTRACT DOCUMENTS.
2. PRIOR TO COMMENCING CONSTRUCTION THE CONTRACTOR SHALL VERIFY ALL EXISTING CONDITIONS IN THE FIELD. IF THE FIELD CONDITIONS DIFFER FROM THOSE SHOWN ON THE PLANS, THE CONTRACTOR SHALL IMMEDIATELY NOTIFY THE ENGINEER.
3. NOTES AND DETAILS ON THESE PLANS SHALL TAKE PRECEDENCE OVER GENERAL NOTES AND TYPICAL DETAILS. WHERE NO DETAILS ARE GIVEN, CONSTRUCTION SHALL BE AS SHOWN FOR SIMILAR WORK.
4. THE WORK SHOWN ON THESE PLANS REQUIRES THE PRIME CONTRACTOR TO POSSESS A VALID CALIFORNIA CLASS A CONTRACTOR'S LICENSE.

**EXISTING & PROPOSED UTILITIES**

5. INFORMATION ON LOCATION, SIZES, AND DEPTH OF THE EXISTING UTILITIES WAS TAKEN FROM EXISTING DRAWINGS AND DATA, AND IS FOR REFERENCE ONLY. THE CONTRACTOR SHALL BECOME FAMILIAR WITH THE PLANS AND SHALL VERIFY SITE CONDITIONS PRIOR TO THE ORDERING OF MATERIALS AND COMMENCING WORK.
6. ANY UTILITY INVESTIGATION DONE BY EXPLORATORY EXCAVATION POTHOLING SHALL USE VACUUM EXTRACTION OR HAND EXCAVATION METHODS ONLY.
7. BEFORE CONSTRUCTION IS STARTED, CONTRACTOR SHALL COORDINATE WITH THE OWNER OF EACH UTILITY AND DEFINE THE REQUIREMENTS AND METHODS TO ACCOMMODATE THE PROTECTION, TEMPORARY SUPPORT, ADJUSTMENT, OR RELOCATION OF ANY UTILITIES AFFECTED BY THE PROPOSED WORK.
8. THE CONTRACTOR SHALL BE COGNIZANT OF ALL OVERHEAD LINES AT ALL TIMES AND SHALL MARK AND PLACE APPROPRIATE SIGNAGE.
9. SHOULD CONFLICTING INFORMATION BE FOUND ON THE PLANS, NOTIFY THE ENGINEER BEFORE PROCEEDING WITH THE WORK IN QUESTION.

**JOB SITE**

10. ALL FIRE HYDRANTS, WATER CONTROL VALVES, AND MAINTENANCE HOLES SHALL BE KEPT FREE FROM OBSTRUCTIONS AND AVAILABLE FOR USE AT ALL TIMES.
11. IN CASE OF SUSPENSION OF WORK FROM ANY CAUSE, THE CONTRACTOR SHALL BE RESPONSIBLE FOR ALL MATERIALS AND SHALL PROPERLY STORE THEM IF NECESSARY AND SHALL ERECT TEMPORARY STRUCTURES WHERE NECESSARY. AGENCY WILL NOT BE HELD RESPONSIBLE FOR THE CARE OR PROTECTION OF ANY MATERIAL OR PARTS OF THE WORK PRIOR TO FINAL ACCEPTANCE, UNLESS OTHERWISE SPECIFIED.
12. THE CONTRACTOR SHALL MAINTAIN AND CLEAN, IF NECESSARY, ALL EXISTING ONSITE AND/OR ADJACENT STORM DRAIN INLETS AFFECTED BY CONSTRUCTION DURING THE COURSE OF CONSTRUCTION AND UNTIL THE WORK IS ACCEPTED BY THE AGENCY.
13. ALL CONSTRUCTION DEBRIS AND FOREIGN MATERIAL SHALL BE REMOVED FROM THE SITE OF THE WORK AND DISPOSED OF AT APPROVED DISPOSAL SITE. THE CONTRACTOR SHALL OBTAIN NECESSARY PERMITS FOR THE TRANSPORTATION AND DISPOSAL OF MATERIAL.

**SURVEY & LAYOUT**

14. CONSTRUCTION STAKING FOR IMPROVEMENTS SHOWN ON THESE PLANS SHALL BE PERFORMED BY A PROFESSIONAL LAND SURVEYOR, POSSESSING A VALID STATE OF CALIFORNIA LAND SURVEYOR LICENSE.

**PUBLIC HEALTH, SAFETY & WELFARE**

15. TRAFFIC CONTROL DEVICES AND METHODS SHALL CONFORM TO THE REQUIREMENTS OF THE "STATE OF CALIFORNIA MANUAL OF TRAFFIC CONTROL" (SAF-T) AND "WORK AREA TRAFFIC CONTROL HANDBOOK" (WATCH) LATEST EDITION.
16. CONTRACTOR SHALL COMPLY WILL ALL LOCAL SOUND CONTROL AND NOISE LEVEL RULES, REGULATIONS AND ORDINANCES, INCLUDING BUT NOT LIMITED TO ALL APPLICABLE PROVISIONS OF THE CITY OF ROSEMEAD AND CITY OF EL MONTE MUNICIPAL CODE.
17. MINIMUM SAFETY STANDARDS: COMPLY WITH ALL APPLICABLE STATE OF CALIFORNIA, DEPARTMENT OF INDUSTRIAL RELATIONS, AND DIVISION OF OCCUPATIONAL SAFETY AND HEALTH (CAL/OSHA) SAFETY STANDARDS.
18. TEMPORARY FACILITIES: CONTRACTOR IS RESPONSIBLE FOR ALL TEMPORARY FACILITIES INCLUDING POWER, WATER, AND SANITARY FACILITIES NEEDED FOR CONSTRUCTION.

**MISCELLANEOUS**

19. ALL FILL SOILS OR SOILS DISTURBED OR OVER-EXCAVATED DURING CONSTRUCTION SHALL BE COMPACTED TO 90% MAXIMUM DENSITY AS DETERMINED BY SOIL COMPACTION TEST ASTM D-1157.
20. CONTRACTOR TO USE AVAILABLE SITE WITHIN THE LIMITS OF WORK FOR STAGING (LAY DOWN AREA) FOR ALL THEIR TOOLS, EQUIPMENT, MATERIAL, AND PARKING.

**DESIGN & CONSTRUCTION STANDARDS:**

21. THE FOLLOWING STANDARD PLANS & SPECIFICATIONS ARE APPLICABLE TO THIS PROJECT:
  - A. STANDARD SPECIFICATIONS FOR PUBLIC WORKS CONSTRUCTION (SPPWC), 2018 EDITION AND SUPPLEMENTS.
  - B. STANDARD PLANS FOR PUBLIC WORKS CONSTRUCTION (SPPWC), 2012 EDITION.

**PUBLIC NOTIFICATION REQUIREMENTS:**

22. THE CONTRACTOR SHALL PROVIDE THE FOLLOWING PUBLIC NOTICES PRIOR TO BEGINNING CONSTRUCTION ON THE PROJECT:
  - A. UPON RECEIVING THE NOTICE TO PROCEED DATE, THE CONTRACTOR SHALL ISSUE A NOTICE BY U.S. MAIL, PREPARED OR APPROVED BY THE AGENCY, NOTIFYING RESIDENTS AND BUSINESSES WITHIN 500 FEET OF THE PROJECT LIMITS ABOUT THE SCHEDULED WORK.
  - B. 2 WEEKS PRIOR TO THE START OF CONSTRUCTION, CONTRACTOR SHALL PREPARE AND DISTRIBUTE A NOTICE APPROVED BY THE AGENCY TO RESIDENTS AND BUSINESSES IMMEDIATELY ADJACENT TO THE PROJECT LIMITS.

**EROSION AND SEDIMENT CONTROL NOTES:**

23. ALL DEBRIS SHALL BE CLEANED UP DAILY AND SECURED AT THE END OF THE DAY.
24. PROTECT DOWNSTREAM CATCH BASINS AND SURFACE WATERS FROM CONVEYANCE OF CONSTRUCTION POLLUTANTS, MAINTAIN AND MODIFY AS NEEDED DURING CONSTRUCTION.
25. ALL CONSTRUCTION/DEMOLITION, GRADING, AND STORAGE OF BULK MATERIALS MUST COMPLY WITH THE SOUTH COAST AIR QUALITY MANAGEMENT DISTRICT (SCAQM) RULE 403 FOR FUGITIVE DUST.

**PRELIMINARY DESIGN  
NOT FOR CONSTRUCTION**

6				SEAL	PREPARED BY:  1561 E. ORANGETHORPE AVE. SUITE 240 FULLERTON, CA 92831 TEL (714) 526-7500 www.cwecorp.com	PROJECT TITLE	PROJECT NO.	
5				DESIGNED BY: TT DATE JUNE 2020		SAN GABRIEL VALLEY COUNCIL OF GOVERNMENTS LOAD REDUCTION STRATEGY PROJECT	18301	
4							DRWG NO.	C-01
3							SHEET	2
2							SHEET TITLE	GENERAL NOTES
1							OF	10
NO.	DATE	REVISIONS		CHECKED BY: KH DATE JUNE 2020				



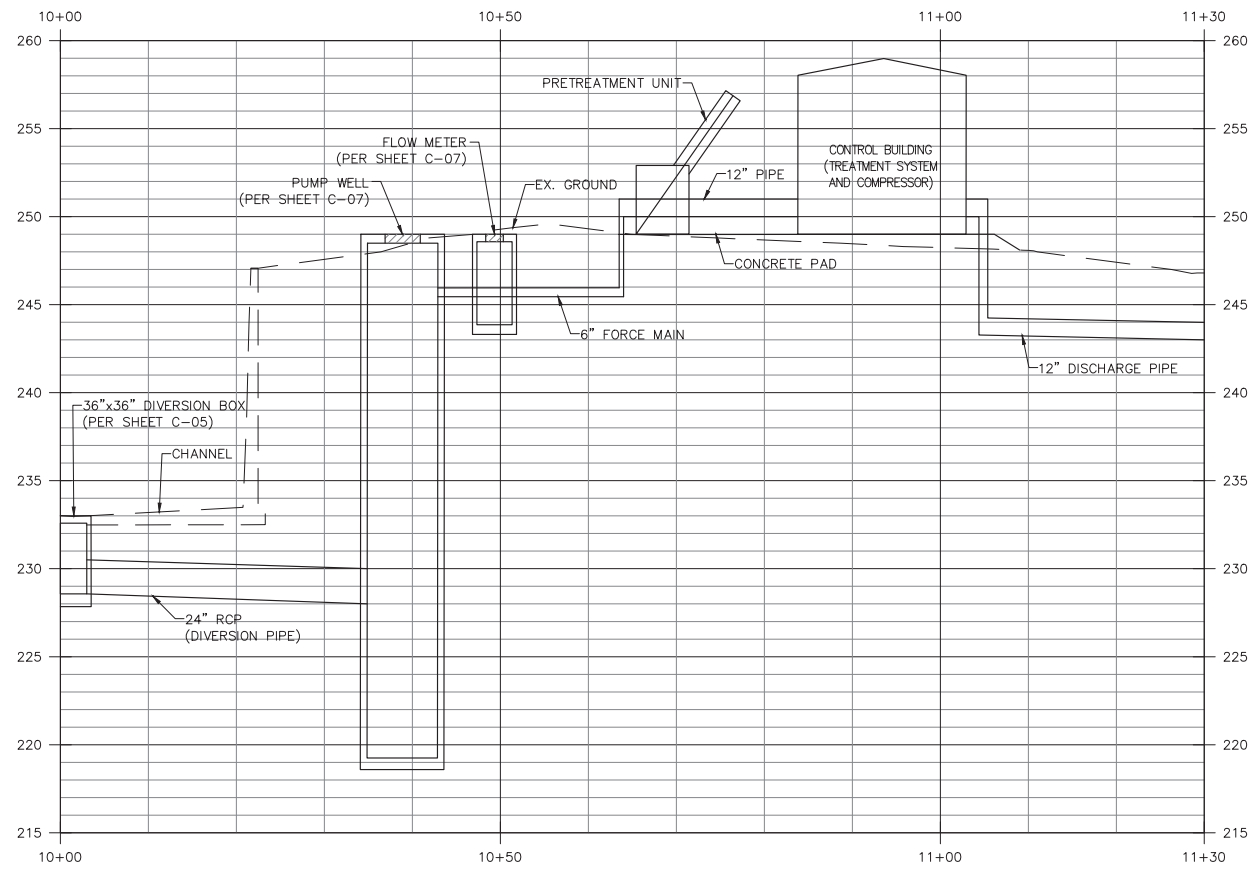

**PROFILE**  
 HORIZ: 1"=10'  
 VERT: 1"=5'

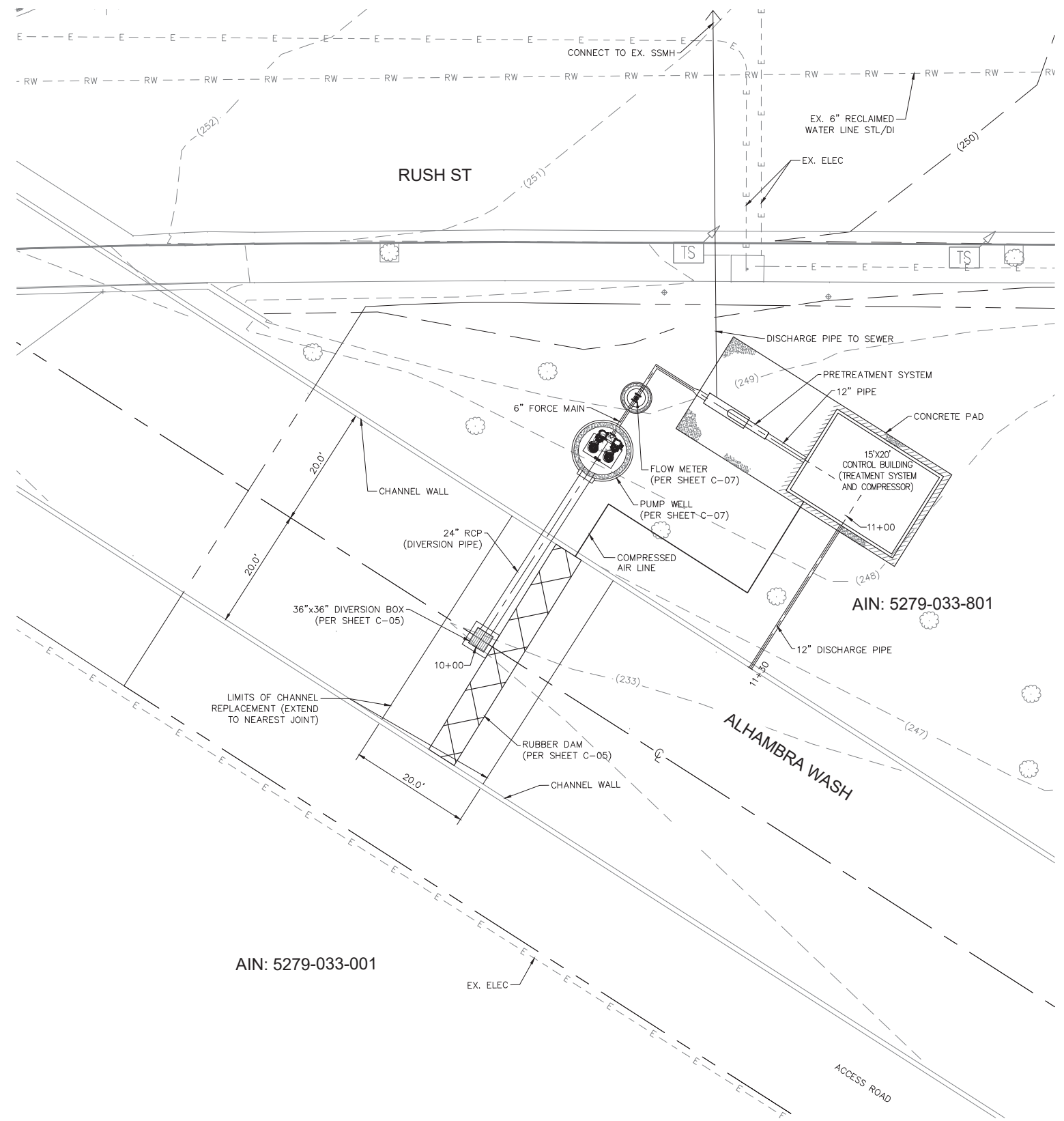

**PLAN**

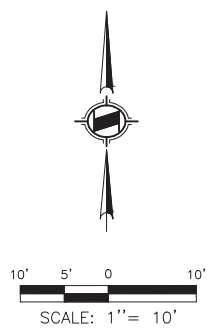

NO.	DATE	REVISIONS
6		
5		
4		
3		
2		
1		

DESIGNED BY: TT	DATE: JUNE 2020
CHECKED BY: KH	DATE: JUNE 2020

SEAL

PREPARED BY:  
  
 1561 E. ORANGETHORPE AVE.  
 SUITE 240  
 FULLERTON, CA 92831  
 TEL (714) 526-7500  
 www.cwecorp.com

PROJECT TITLE  
**SAN GABRIEL VALLEY COUNCIL OF GOVERNMENTS**  
 LOAD REDUCTION STRATEGY PROJECT

SHEET TITLE  
**ALHAMBRA WASH DIVERSION PLAN**

PROJECT NO.  
**18301**

DRWG NO. **C-02**

SHEET **3**

OF **10**

**PRELIMINARY DESIGN**  
**NOT FOR CONSTRUCTION**





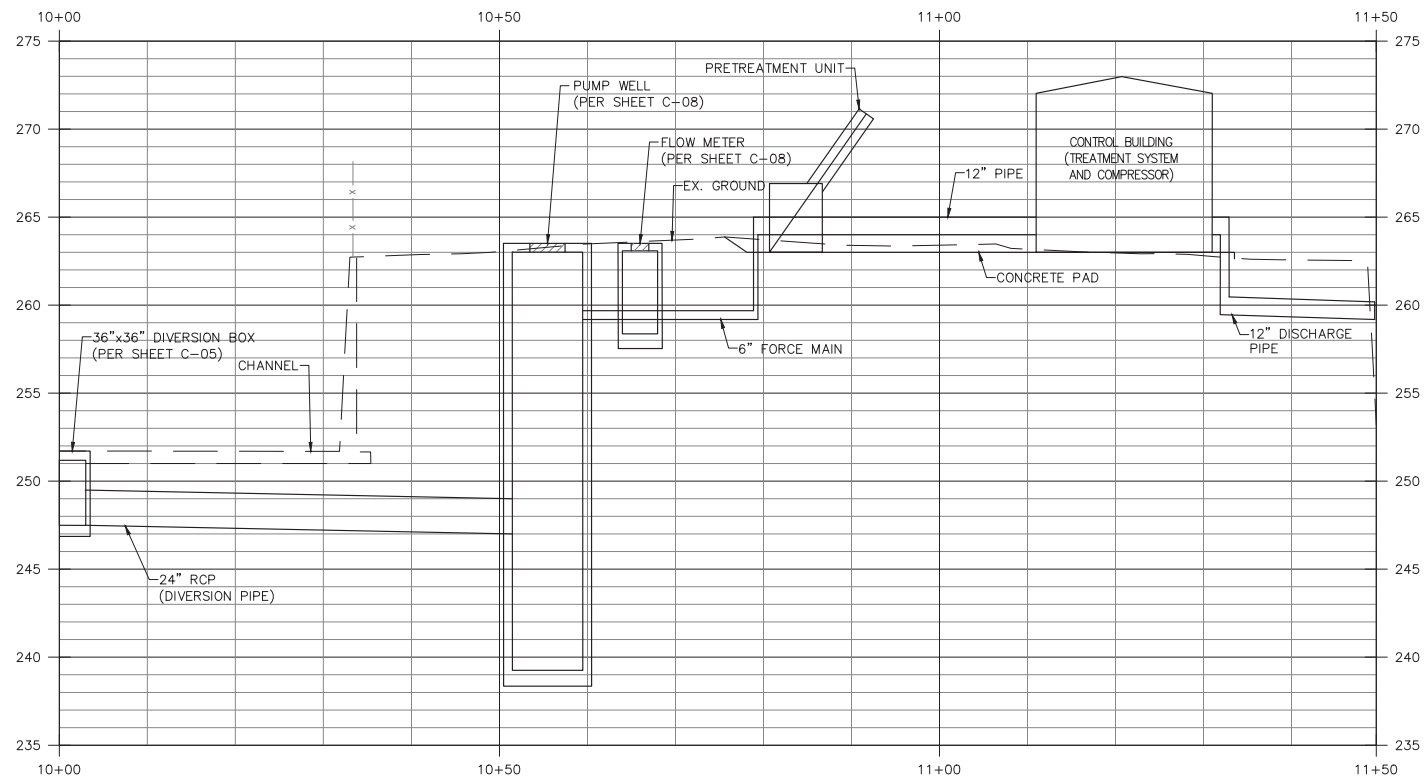

**PROFILE**  
 HORIZ: 1"=10"  
 VERT: 1"=5'

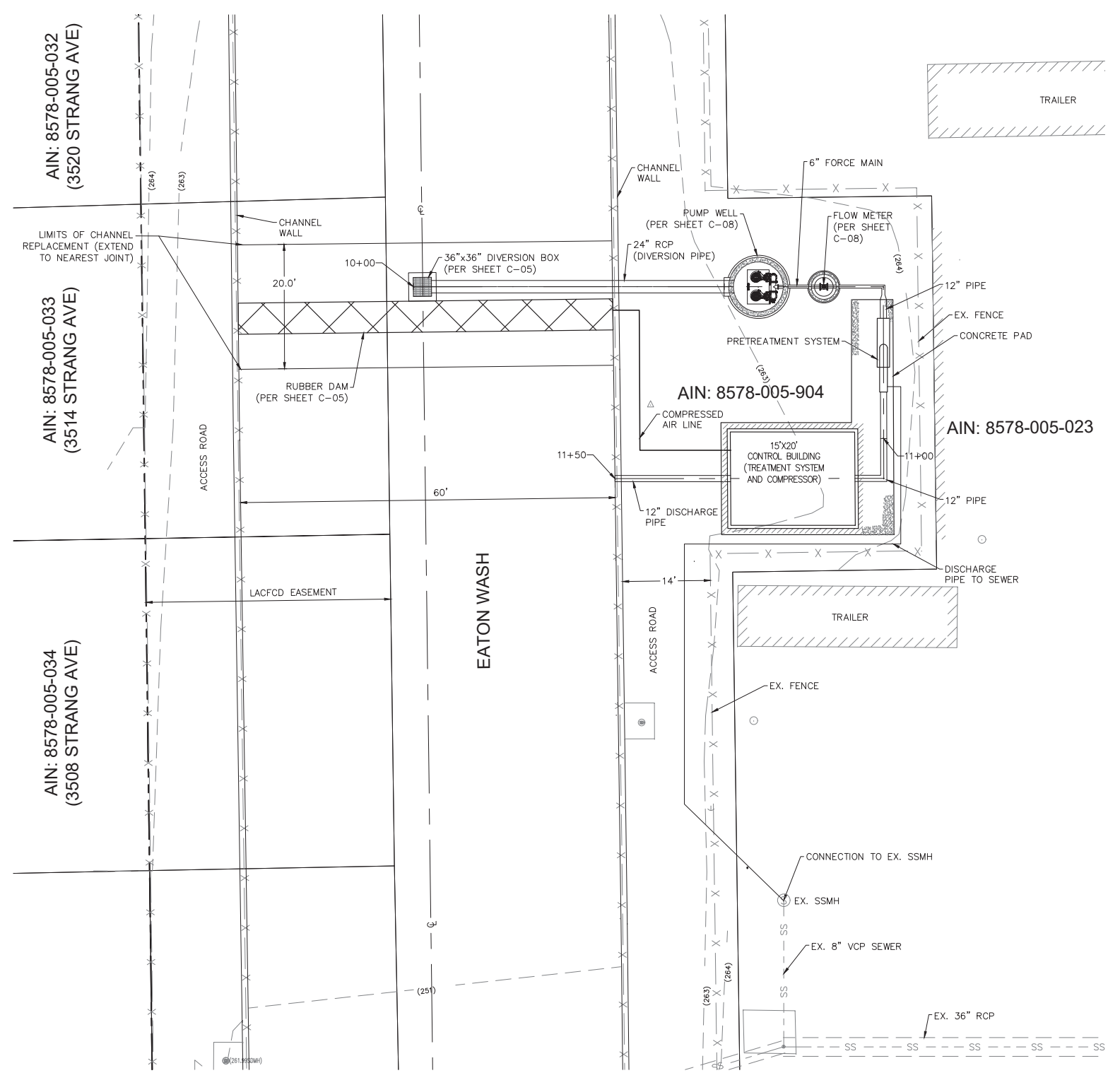

**PLAN**

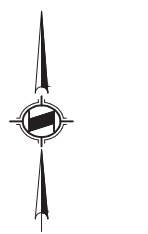

10' 5' 0' 10'  
 SCALE: 1" = 10'

**PRELIMINARY DESIGN  
 NOT FOR CONSTRUCTION**

NO.		DATE		REVISIONS		DESIGNED BY: TT	DATE JUNE 2020	CHECKED BY: KH	DATE JUNE 2020	SEAL	PREPARED BY: <b>CWE</b> 1561 E. ORANGETHORPE AVE. SUITE 240 FULLERTON, CA 92831 TEL (714) 526-7500 www.cwecorp.com	PROJECT TITLE <b>SAN GABRIEL VALLEY COUNCIL OF GOVERNMENTS LOAD REDUCTION STRATEGY PROJECT</b>	PROJECT NO. 18301
SHEET TITLE <b>EATON WASH DIVERSION PLAN</b>													DRWG NO. <b>C-03</b>
													SHEET <b>4</b>
													OF <b>10</b>



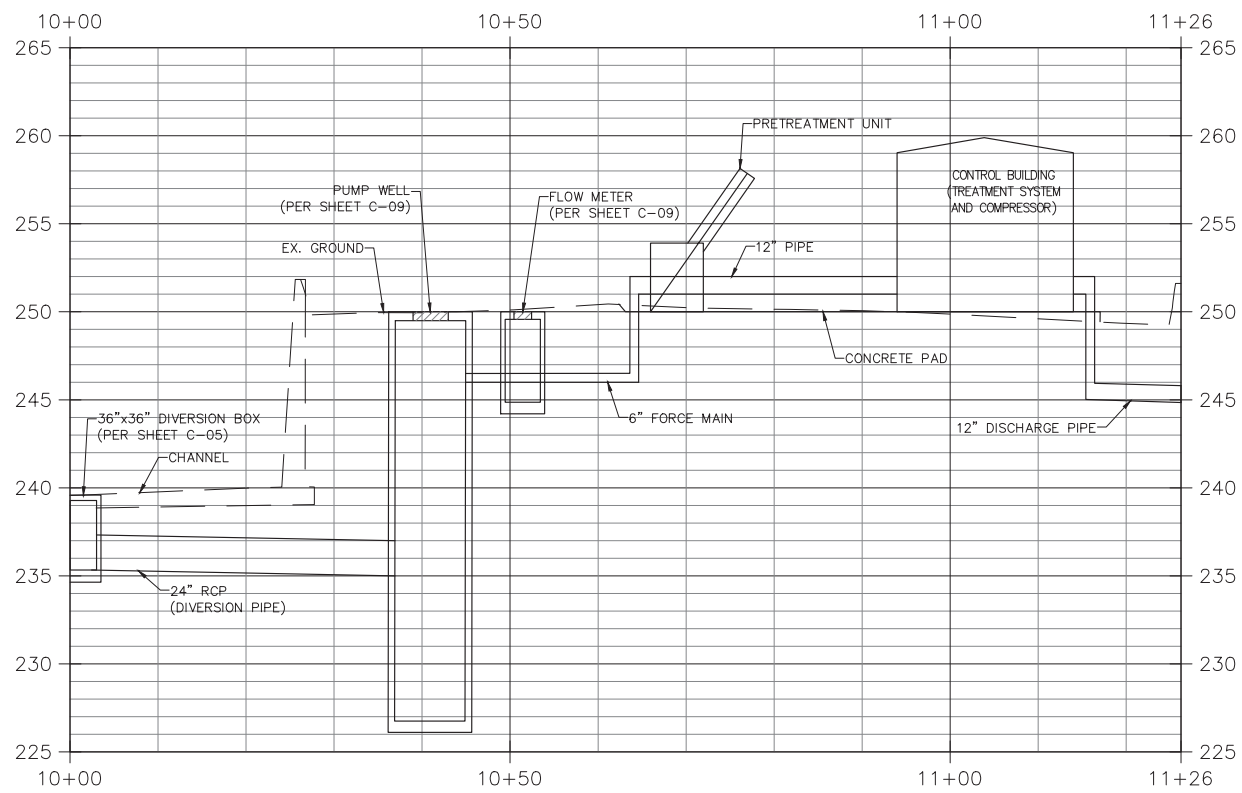

**PROFILE**  
 HORIZ: 1"=10'  
 VERT: 1"=5'

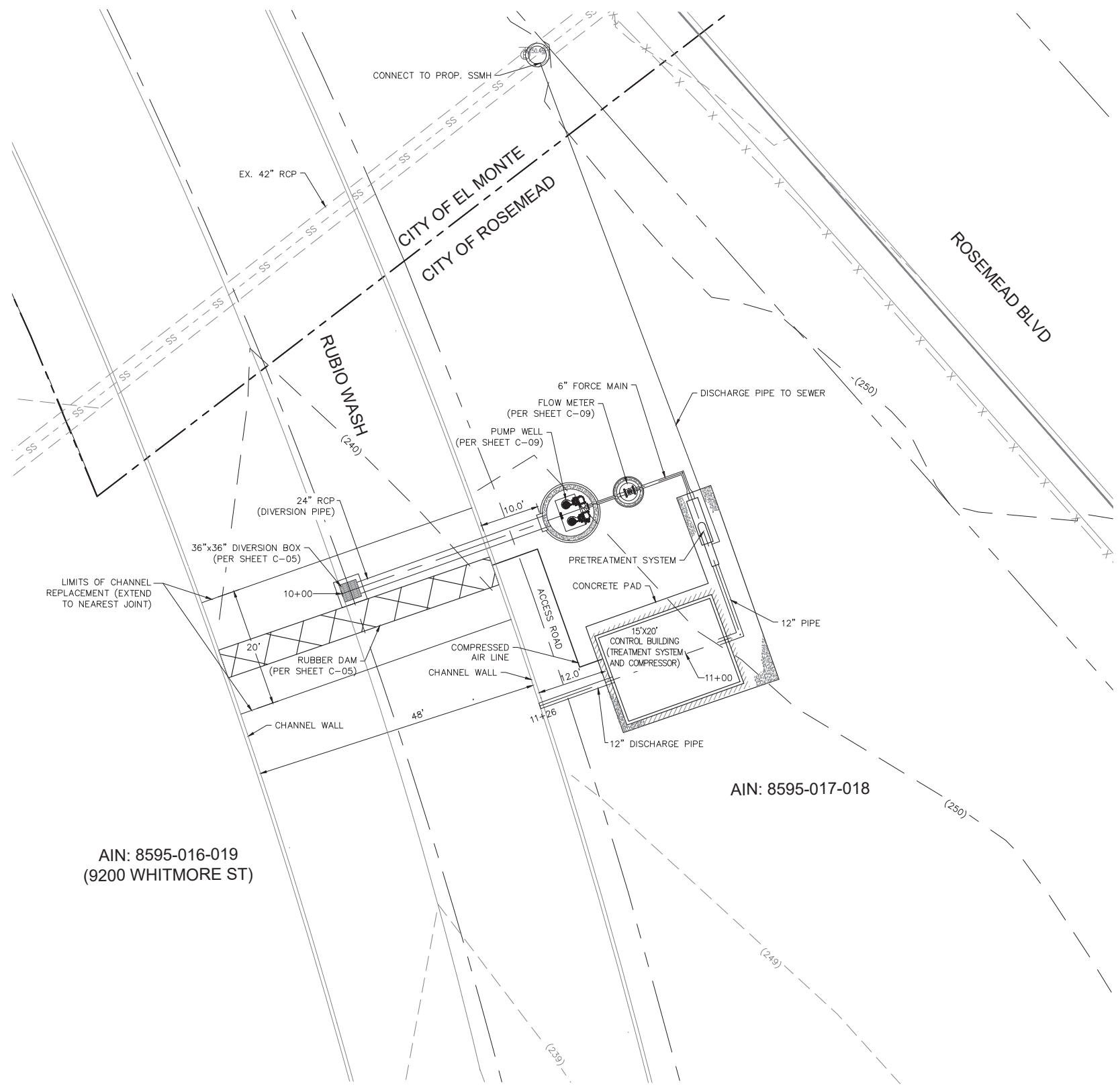

**PLAN**

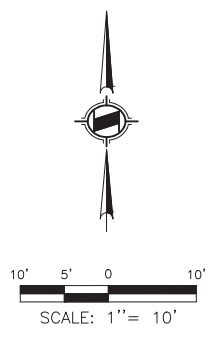

**PRELIMINARY DESIGN  
 NOT FOR CONSTRUCTION**

6				SEAL	PREPARED BY:	 1561 E. ORANGETHORPE AVE. SUITE 240 FULLERTON, CA 92831 TEL (714) 526-7500 www.cwecorp.com	PROJECT TITLE	PROJECT NO.
5				DESIGNED BY: TT	DATE		SAN GABRIEL VALLEY COUNCIL OF GOVERNMENTS	18301
4				CHECKED BY: KH	DATE	LOAD REDUCTION STRATEGY PROJECT	DRWG NO. C-04	
3					JUNE 2020	SHEET TITLE	SHEET 5	
2						RUBIO WASH DIVERSION PLAN	OF 10	
1								
NO.	DATE		REVISIONS					



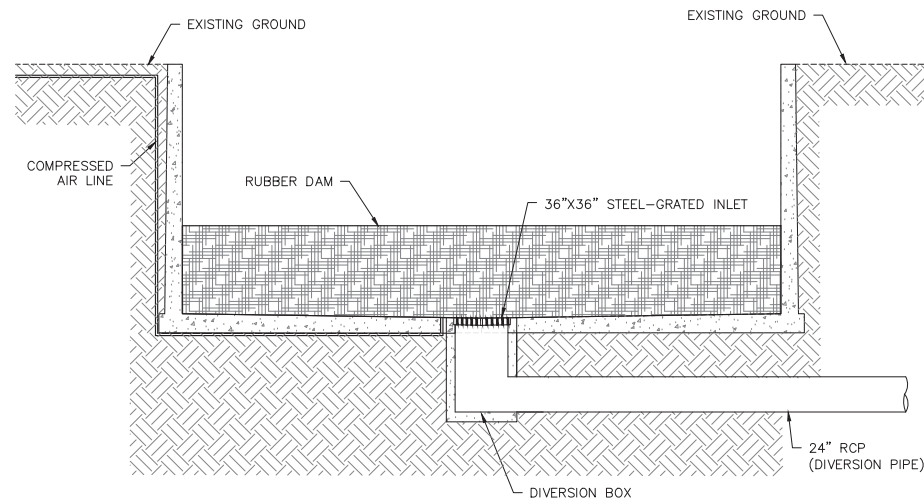

**DETAIL A: DROP INLET AND RUBBER DAM**  
NOT TO SCALE

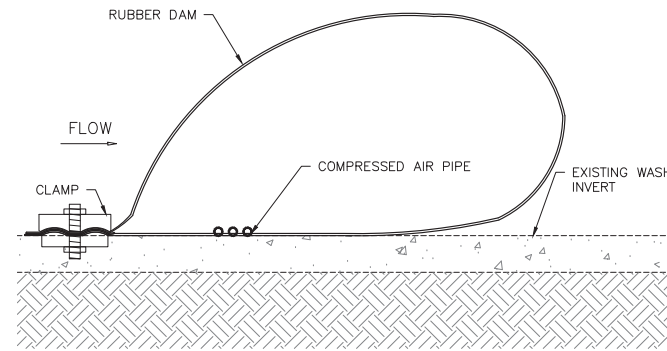

**DETAIL B: RUBBER DAM**  
SCALE: 1"=5'

**DETAIL C: DIVERSION BOX**  
SCALE: 1"=5'

**DETAIL D: PRETREATMENT SYSTEM**  
SCALE: 1"=10'

PRELIMINARY DESIGN  
NOT FOR CONSTRUCTION

6				SEAL	PREPARED BY:	PROJECT TITLE	PROJECT NO.
5					 1561 E. ORANGETHORPE AVE. SUITE 240 FULLERTON, CA 92831 TEL (714) 526-7500 www.cwecorp.com	SAN GABRIEL VALLEY COUNCIL OF GOVERNMENTS LOAD REDUCTION STRATEGY PROJECT	18301
4				DRWG NO.			C-05
3				SHEET			6
2				OF			10
1							
NO.	DATE	REVISIONS		CHECKED BY:	DATE	DETAILS	
				KH	JUNE 2020		



TREATMENT SYSTEM: PLAN  
1"=10'

CMU BUILDING: PLAN  
1"=10'

TREATMENT SYSTEM: ELEVATION  
1"=10'

CMU BUILDING: ELEVATION  
1"=10'

PRELIMINARY DESIGN  
NOT FOR CONSTRUCTION

6				DESIGNED BY: TT	DATE	PREPARED BY:  1561 E. ORANGETHORPE AVE. SUITE 240 FULLERTON, CA 92831 TEL (714) 526-7500 www.cwecorp.com	PROJECT TITLE	PROJECT NO.
5					JUNE 2020		SAN GABRIEL VALLEY COUNCIL OF GOVERNMENTS	18301
4							LOAD REDUCTION STRATEGY PROJECT	DRWG NO. C-06
3							SHEET TITLE	SHEET 7
2							TREATMENT SYSTEM	OF 10
1								
NO.	DATE	REVISIONS		CHECKED BY: KH	DATE			
					JUNE 2020			

SEAL





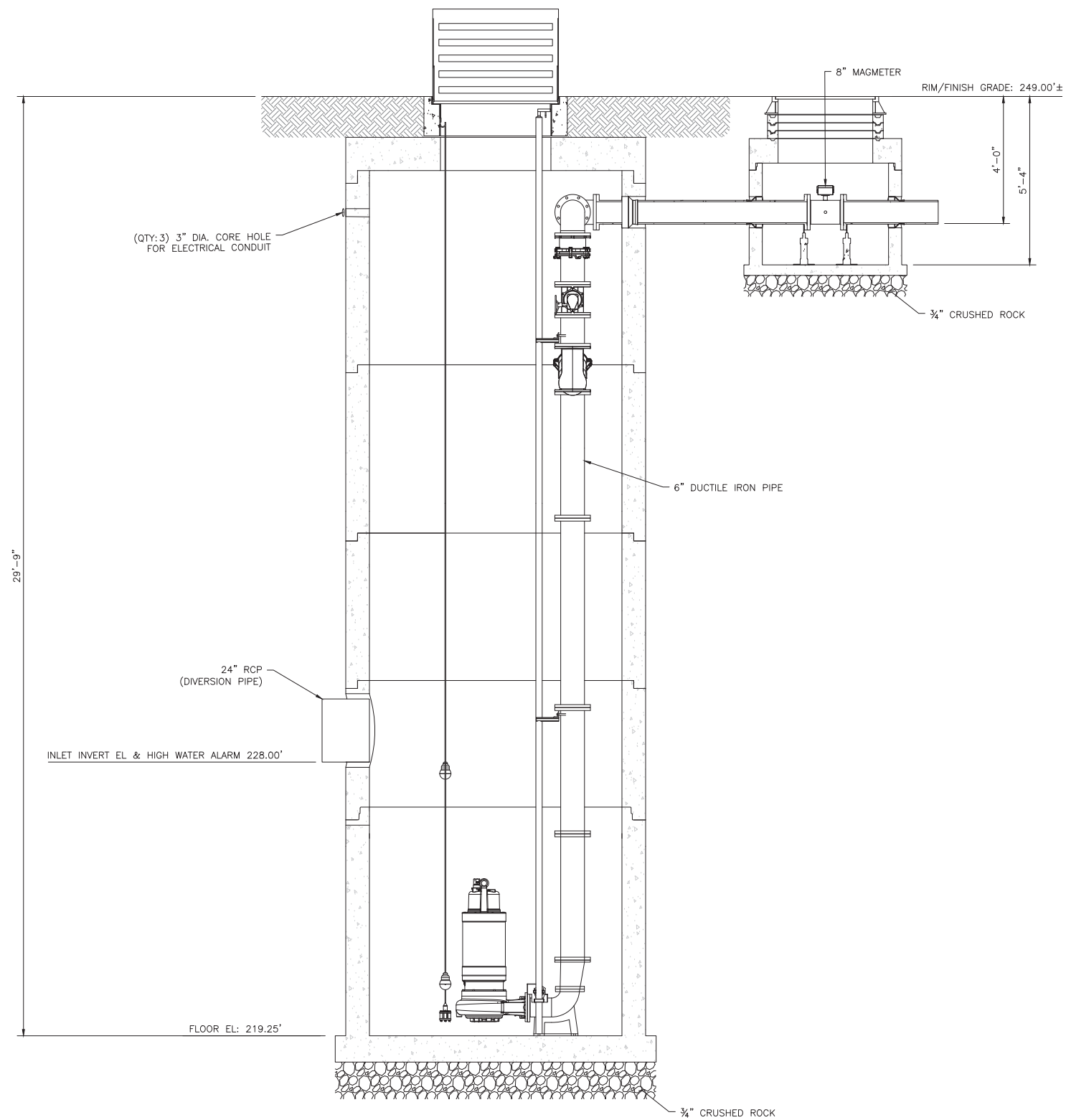

**PROFILE SECTION VIEW**  
SCALE: 1" = 2'

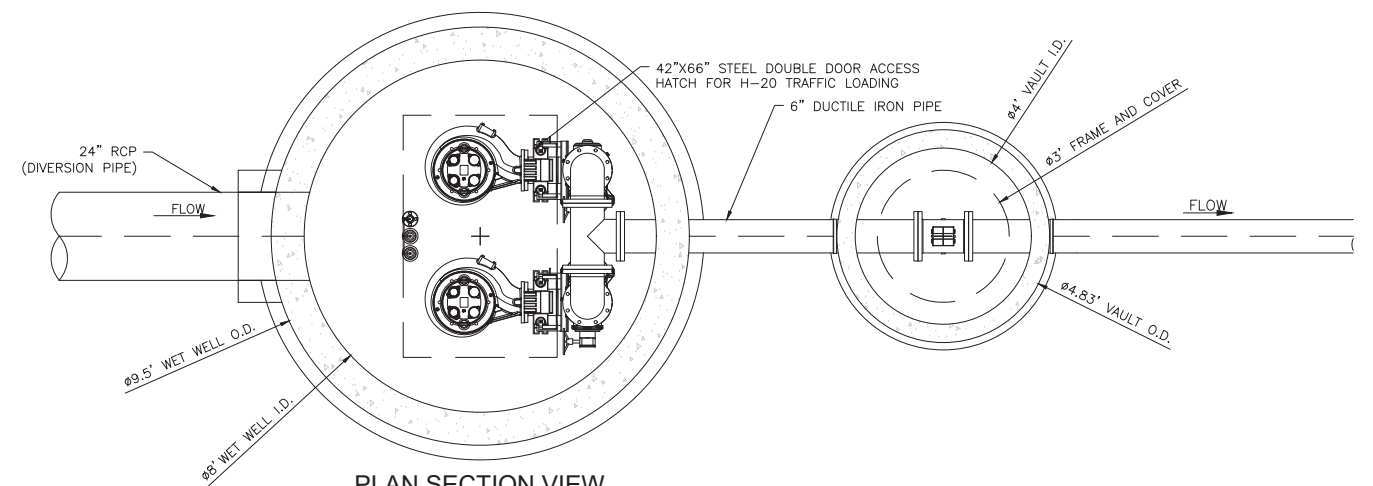

**PLAN SECTION VIEW**  
SCALE: 1" = 2'

SYSTEM CHARACTERISTICS	
DESCRIPTION	VALUE
DUTY POINT	1000 gpm @ 38.2' TDH
MANUFACTURER	HOMA OR AGENCY APPROVED EQUAL
MODEL NUMBER	AMX-646-350/21.5PUFM
PUMP TYPE	SUBMERSIBLE NON-CLOG
MOTOR SIZE	21.5 hp, 30 FLA
AVAILABLE POWER	480 V, 3 Ph

**PRELIMINARY DESIGN  
NOT FOR CONSTRUCTION**

NO.	DATE	REVISIONS
6		
5		
4		
3		
2		
1		

DESIGNED BY: TT	DATE: JUNE 2020
CHECKED BY: KH	DATE: JUNE 2020

SEAL

PREPARED BY:  
**CWE**  
1561 E. ORANGETHORPE AVE.  
SUITE 240  
FULLERTON, CA 92831  
TEL (714) 526-7500  
www.cwecorp.com

PROJECT TITLE  
**SAN GABRIEL VALLEY COUNCIL OF GOVERNMENTS  
LOAD REDUCTION STRATEGY PROJECT**

SHEET TITLE  
**ALHAMBRA WASH DIVERSION PUMP**

PROJECT NO.  
**18301**

DRWG NO. **C-07**

SHEET **8**

OF **10**



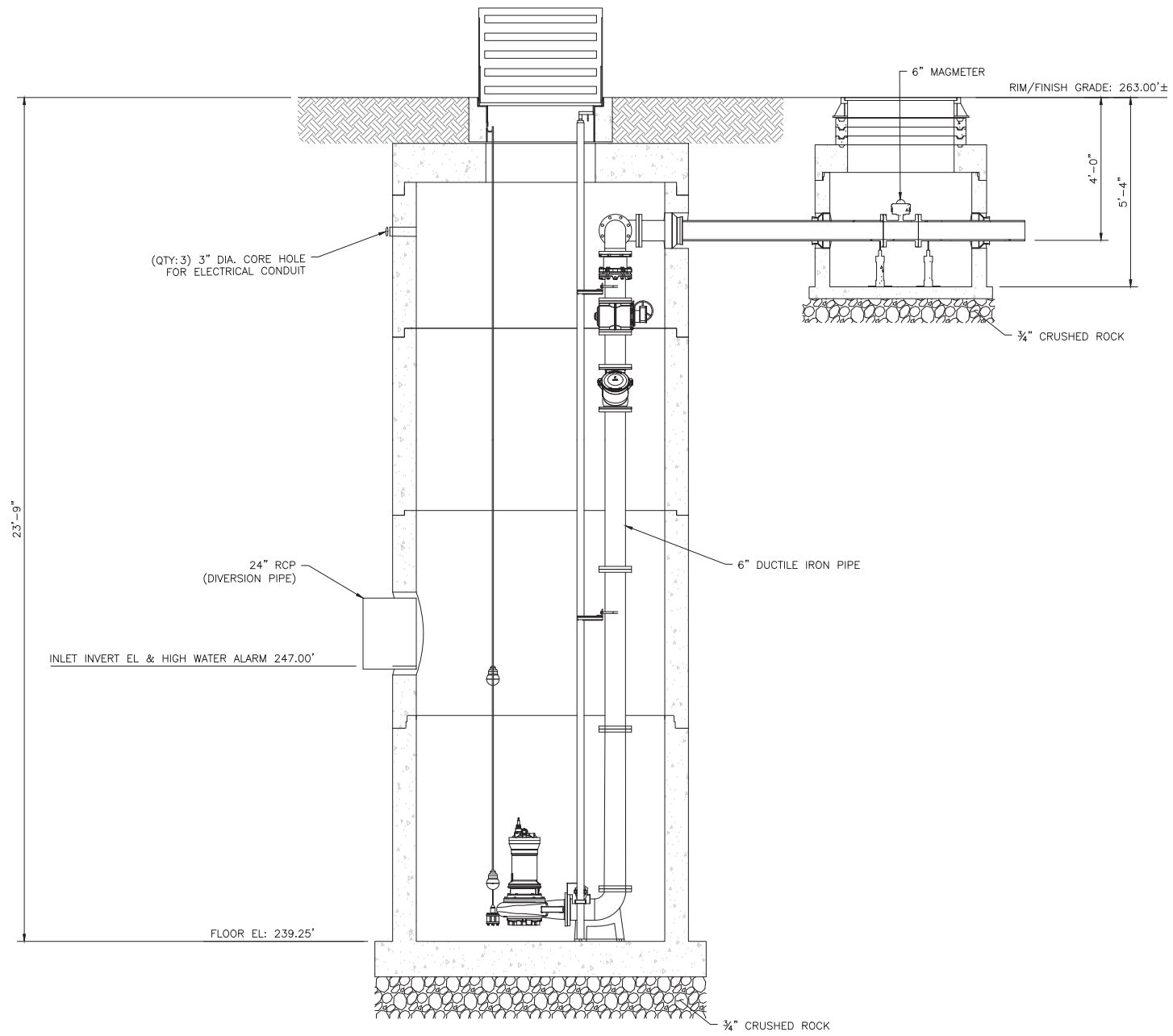

**PROFILE SECTION VIEW**  
SCALE: 1" = 2'

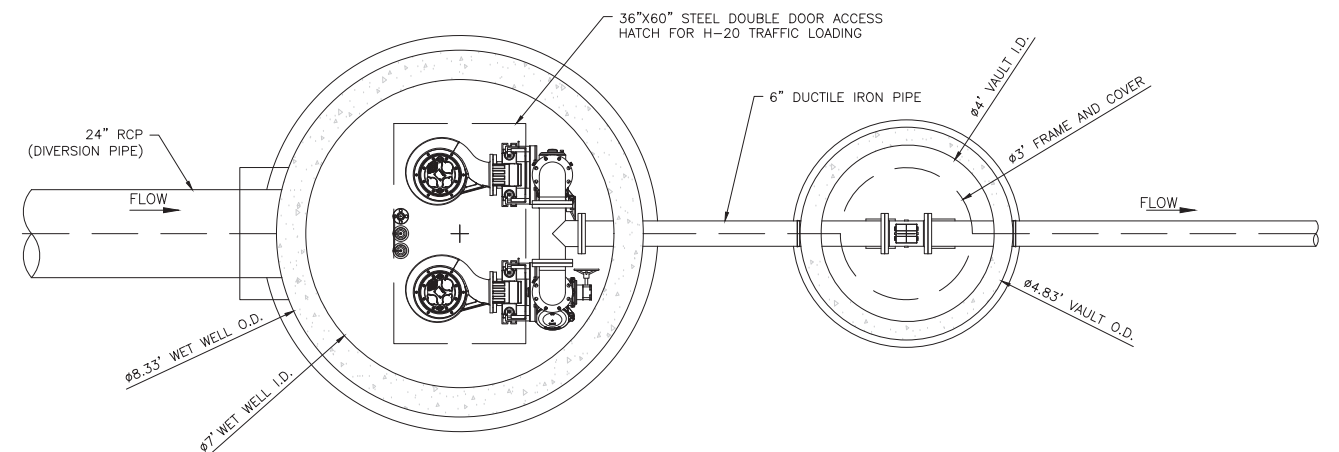

**PLAN SECTION VIEW**  
SCALE: 1" = 2'

SYSTEM CHARACTERISTICS	
DESCRIPTION	VALUE
DUTY POINT	630 gpm @ 37.4' TDH
MANUFACTURER	HOMA OR AGENCY APPROVED EQUAL
MODEL NUMBER	AMS-646-285/9.8PUFM
PUMP TYPE	SUBMERSIBLE NON-CLOG
MOTOR SIZE	9.8 hp, 14 FLA
AVAILABLE POWER	480 V, 3 Ph

**PRELIMINARY DESIGN  
NOT FOR CONSTRUCTION**

NO.	DATE	REVISIONS
6		
5		
4		
3		
2		
1		

DESIGNED BY: TT	DATE: JUNE 2020
CHECKED BY: KH	DATE: JUNE 2020

SEAL

PREPARED BY:  
**CWE**  
1561 E. ORANGETHORPE AVE.  
SUITE 240  
FULLERTON, CA 92831  
TEL (714) 526-7500  
www.cwecorp.com

PROJECT TITLE  
**SAN GABRIEL VALLEY COUNCIL OF GOVERNMENTS  
LOAD REDUCTION STRATEGY PROJECT**

SHEET TITLE  
**EATON WASH DIVERSION PUMP**

PROJECT NO.  
**18301**

DRWG NO. **C-08**

SHEET **9**

OF **10**



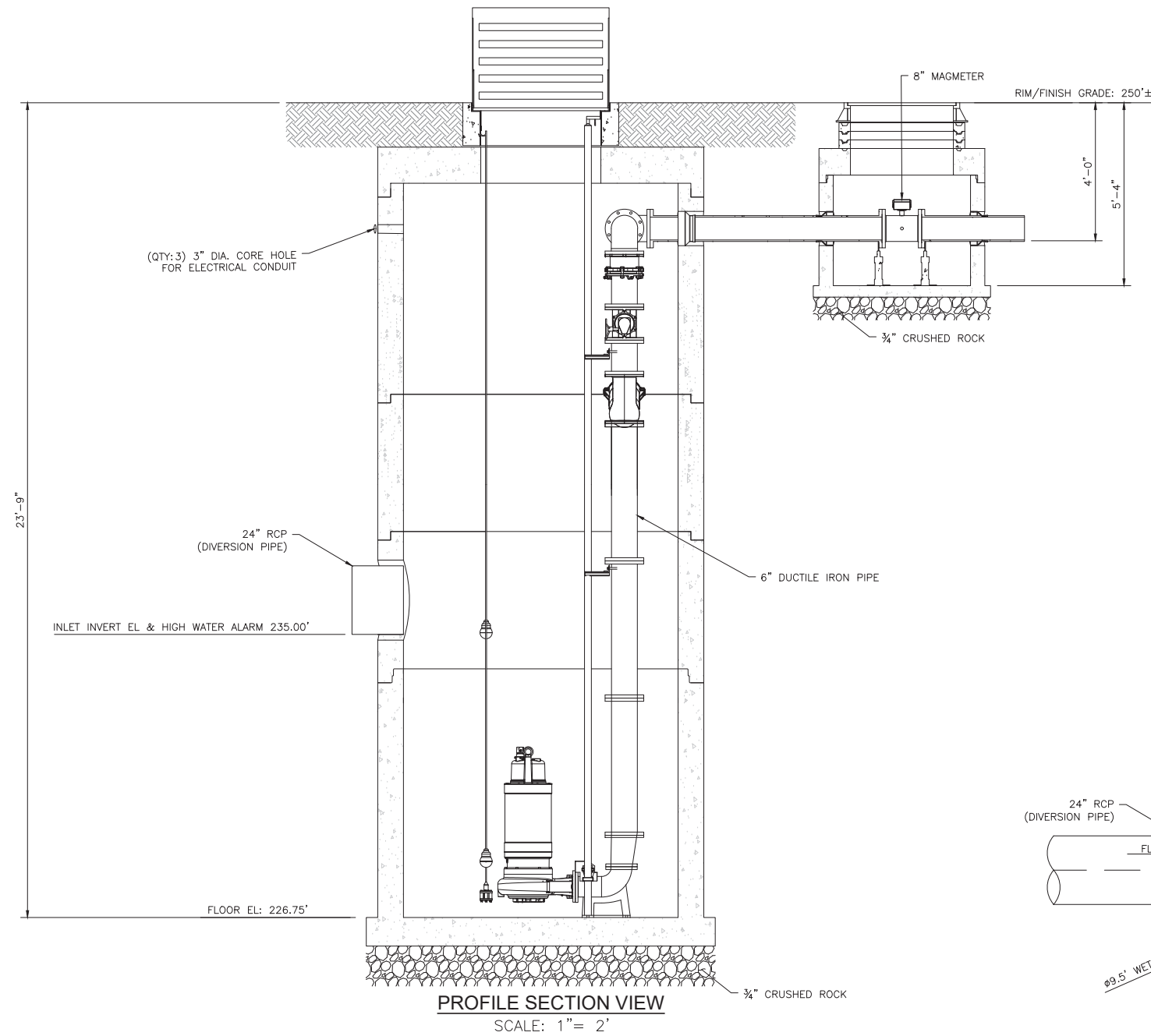

SYSTEM CHARACTERISTICS	
DESCRIPTION	VALUE
DUTY POINT	1000 gpm @ 38.2' TDH
MANUFACTURER	HOMA OR AGENCY APPROVED EQUAL
MODEL NUMBER	AMX-646-350/21.5PUFM
PUMP TYPE	SUBMERSIBLE NON-CLOG
MOTOR SIZE	21.5 hp, 30 FLA
AVAILABLE POWER	480 V, 3 Ph

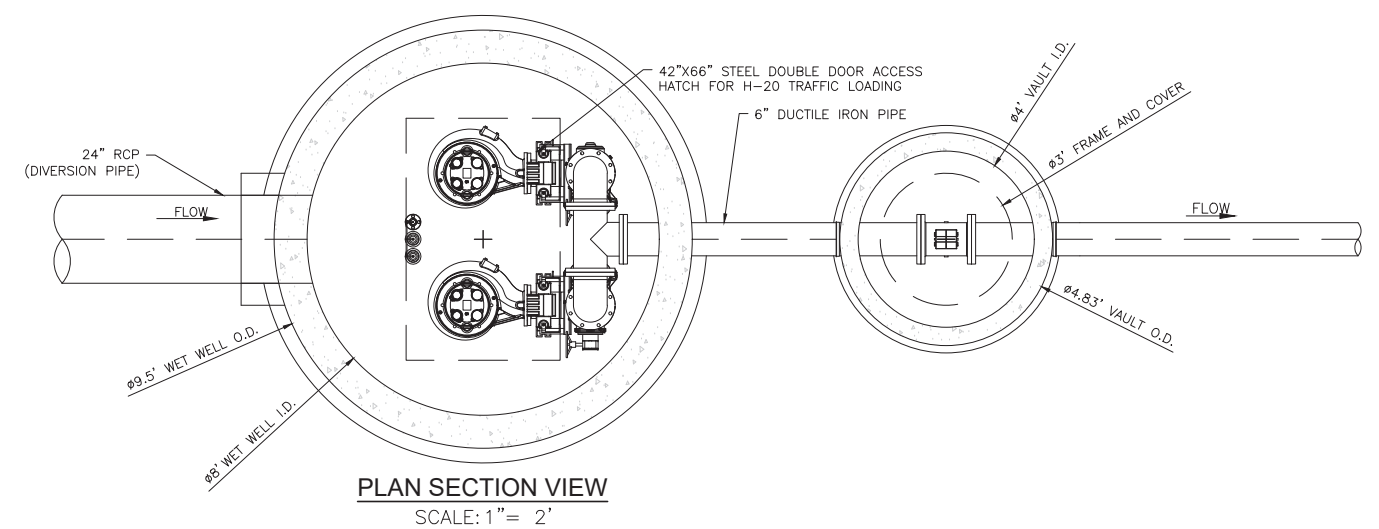

**PRELIMINARY DESIGN  
NOT FOR CONSTRUCTION**

NO.	DATE	REVISIONS
6		
5		
4		
3		
2		
1		

DESIGNED BY: TT	DATE: JUNE 2020
CHECKED BY: KH	DATE: JUNE 2020

SEAL

PREPARED BY:  
  
 1561 E. ORANGETHORPE AVE.  
 SUITE 240  
 FULLERTON, CA 92831  
 TEL (714) 526-7500  
 www.cwecorp.com

PROJECT TITLE  
**SAN GABRIEL VALLEY COUNCIL OF GOVERNMENTS**  
 LOAD REDUCTION STRATEGY PROJECT

SHEET TITLE  
**RUBIO WASH DIVERSION PUMP**

PROJECT NO.  
**18301**

DRWG NO. **C-09**

SHEET **10**

OF **10**





**San Gabriel Valley  
Council of Governments**  
**Load Reduction Strategy Feasibility  
Assessment Report**  
**FINAL**



1561 E. Orangethorpe Avenue, Suite 240  
Fullerton, California 92831  
TEL (714) 526-7500 | FAX (714) 526-7004  
[www.cwecorp.com](http://www.cwecorp.com)





# **San Gabriel Valley Council of Governments**

## **Load Reduction Strategy Feasibility Assessment Report**

**FINAL**

**Prepared for:**



San Gabriel Valley Council of Governments  
4900 Rivergrade Road, Suite A120  
Irwindale, California 91706  
TEL (626) 457-1800

**Prepared by:**



1561 E. Orangethorpe Avenue, Suite 240  
Fullerton, California 92831

TEL (714) 526-7500 | FAX (714) 526-7004 | [www.cwecorp.com](http://www.cwecorp.com)

**June 16, 2020**

# Table of Contents

**TABLE OF CONTENTS..... i**

**LIST OF FIGURES .....iv**

**LIST OF TABLES.....iv**

**ACRONYMS.....vi**

**1. BACKGROUND ..... 1**

**2. PROJECT PURPOSE AND GOALS..... 3**

**3. EXISTING CONDITIONS..... 5**

3.1 SITE LOCATION .....5

3.1.1 Alhambra Wash .....5

3.1.2 Eaton Wash .....6

3.1.3 Rubio Wash .....7

3.2 TOPOGRAPHY .....8

3.2.1 Alhambra Wash .....8

3.2.2 Eaton Wash .....9

3.2.3 Rubio Wash .....10

3.3 GEOTECHNICAL.....11

3.3.1 Alhambra Wash .....11

3.3.2 Eaton Wash .....13

3.3.3 Rubio Wash .....14

3.4 UTILITIES.....16

3.4.1 Alhambra Wash .....16

3.4.2 Eaton Wash .....17

3.4.3 Rubio Wash .....18

**4. PROPOSED IMPROVEMENTS..... 20**

4.1 ALHAMBRA WASH.....20

4.1.1 Alhambra Wash Alternative A1: No Storage .....20

4.1.2 Alhambra Wash Alternative A2: In-Line Storage .....21

4.1.3 Alhambra Wash Alternative A3: Off-Line Storage .....22

4.2 EATON WASH.....23

4.2.1 Eaton Wash Alternative E1: No Storage .....23

4.2.2 Eaton Wash Alternative E2: In-Line Storage .....24

4.3 RUBIO WASH .....25

4.3.1 Rubio Wash Alternative R1: No Storage .....25

4.3.2 Rubio Wash Alternative R2: In-Line Storage .....26

4.3.3 Rubio Wash Alternative R3: Off-Line Storage .....27

**5. SEWER DIVERSION PROJECT COMPONENTS..... 29**

5.1 DIVERSION SYSTEM .....29

5.1.1 Diversion Alternative 1: Grated Trench .....29

5.1.2 Diversion Alternative 2: Concrete Weir .....30

5.1.3 Diversion Alternative 3: Rubber Dam .....31



5.2 PUMP ..... 33

5.3 STORAGE ..... 33

5.4 SEWER CONNECTION..... 34

**6. FLOW ANALYSIS..... 35**

6.1 DATA ANALYSIS APPROACH..... 35

6.2 COMPARISON OF DISCHARGE AND LRS FLOW RATES ..... 36

6.3 AVERAGE DRY-WEATHER DISCHARGE FLOW RATES..... 37

6.4 ANALYSIS 1: LRS DISCHARGE WITH NO STORAGE ..... 38

6.5 ANALYSIS 2: STORAGE WITH OPTIMIZED DISCHARGE RATES ..... 38

**7. OPERATIONS AND MAINTENANCE..... 40**

7.1 SANITARY SEWER DISCHARGE FEES ..... 41

7.2 WATERMASTER FEES ..... 41

**8. PROBABLE COSTS..... 43**

8.1 ALHAMBRA WASH..... 43

8.1.1 Alhambra Wash Alternative A1: No Storage ..... 43

8.1.2 Alhambra Wash Alternative A2: In-Line Storage..... 44

8.1.3 Alhambra Wash Alternative A3: Off-Line Storage ..... 44

8.2 EATON WASH..... 45

8.2.1 Eaton Wash Alternative E1: No Storage..... 45

8.2.2 Eaton Wash Alternative E2: In-Line Storage..... 46

8.3 RUBIO WASH ..... 46

8.3.1 Rubio Wash Alternative R1: No Storage..... 46

8.3.2 Rubio Wash Alternative R2: In-Line Storage ..... 47

8.3.3 Rubio Wash Alternative R3: Off-Line Storage..... 47

**9. PERMITS AND EASEMENT EVALUATION ..... 49**

9.1 USACE SECTION 408 ..... 49

9.2 CLEAN WATER ACT SECTION 404..... 50

9.3 FISH AND WILDLIFE CODE 1600..... 51

9.4 CLEAN WATER ACT SECTION 401..... 51

9.5 GENERAL NPDES PERMIT No. CAG994004 ..... 52

9.6 DIVISION OF STATE ARCHITECT ..... 53

9.7 LACFCD CONNECTION PERMIT..... 54

9.7.1 LACFCD Use Agreement ..... 54

9.8 LACSD CONNECTION PERMIT ..... 55

9.8.1 Requirements for Discharge of Dry-Weather Flows..... 55

9.9 RIGHT-OF-WAY VALUATION..... 56

9.9.1 Alhambra Wash ..... 56

9.9.2 Rubio Wash ..... 57

9.9.3 Acquisition Procedures ..... 58

9.10 LOCAL REQUIREMENTS..... 58

**10. ADDITIONAL TREATMENT ALTERNATIVES ..... 59**

10.1 TREATMENT ALTERNATIVE T1: ADVANCED TREATMENT FOR RELEASE ..... 59

10.1.1 Treatment Approach ..... 60



10.1.2 Site Requirements and Existing Constraints .....61

10.1.3 Operation and Maintenance .....61

10.1.4 Similar Projects and Probable Cost .....62

10.1.5 Permitting .....63

10.1.6 Pros and Cons .....63

10.1.7 Next Steps.....63

10.2 TREATMENT ALTERNATIVE T2: TITLE 22 TREATMENT FOR DISCHARGE INTO EXISTING RECYCLED WATER SYSTEM .....63

10.2.1 Treatment Approach .....64

10.2.2 Site Requirements and Existing Constraints .....65

10.2.3 Operation and Maintenance .....66

10.2.4 Similar Projects and Probable Cost .....67

10.2.5 Permitting .....67

10.2.6 Pros and Cons .....68

10.2.7 Next Steps.....69

10.3 TREATMENT ALTERNATIVE T3: ADVANCED TREATMENT FOR GROUNDWATER INJECTION .....69

10.3.1 Treatment Approach .....69

10.3.2 Site Requirements and Existing Constraints .....71

10.3.3 Operation and Maintenance .....71

10.3.4 Similar Projects and Probable Cost .....72

10.3.5 Permitting .....72

10.3.6 Pros and Cons .....73

10.3.7 Next Steps.....74

**11. SUMMARY AND RECOMMENDATIONS ..... 75**

11.1 COST OPINION .....76

**12. REFERENCES ..... 79**

## Appendices

Appendix A Topographic Surveys

Appendix B Geotechnical Report

Appendix C Utility Log

Appendix D Proposed Improvements

Appendix E Diversion Alternatives

Appendix F Dry-Weather Flows Field Investigation

Appendix G Flow Analysis

Appendix H Main San Gabriel Basin Watermaster Letter

Appendix I Section 408 Related Documents

Appendix J CWA 404 Certification Related Documents

Appendix K Fish and Wildlife Code 1600 Related Documents

Appendix L CWA 401 Certification Related Documents

Appendix M General NPDES Permit No. CAG994004 Related Documents

Appendix N DSA Related Documents

Appendix O LACFCD Connection Permit Related Documents



Appendix P LACSD Connection Permit Related Documents  
 Appendix Q Right-of-Way Valuation Service  
 Appendix R LADPH Cross Connection and Water Pollution Control Program Documents  
 Appendix S Caltrans Encroachment Permit Documents  
 Appendix T UIC Reporting Forms  
 Appendix U Preliminary Plans for Recommended Design

## List of Figures

Figure 1-1 Project Sites .....2  
 Figure 2-1 General LRS Project Concept .....3  
 Figure 3-1 Alhambra Wash Site Location .....6  
 Figure 3-2 Eaton Wash Site Location .....7  
 Figure 3-3 Rubio Wash Site Location .....8  
 Figure 3-4 Alhambra Wash Site Topography .....9  
 Figure 3-5 Eaton Wash Site Topography .....10  
 Figure 3-6 Rubio Wash Site Topography .....11  
 Figure 3-7 Boring Sites at Alhambra Wash .....12  
 Figure 3-8 Boring Sites at Eaton Wash .....14  
 Figure 3-9 Boring Sites at Rubio Wash .....15  
 Figure 3-10 Utilities at Alhambra Wash .....17  
 Figure 3-11 Utilities at Eaton Wash .....18  
 Figure 3-12 Utilities at Rubio Wash .....19  
 Figure 4-1 Alhambra Wash Alternative A1: No Storage .....21  
 Figure 4-2 Alhambra Wash Alternative A2: In-Line Storage .....22  
 Figure 4-3 Alhambra Wash Alternative A3: Off-Line Storage .....23  
 Figure 4-4 Eaton Wash Alternative E1: No Storage .....24  
 Figure 4-5 Eaton Wash Alternative E2: In-Line Storage .....25  
 Figure 4-6 Rubio Wash Alternative R1: No Storage .....26  
 Figure 4-7 Rubio Wash Alternative R2: In-Line Storage .....27  
 Figure 4-8 Rubio Wash Alternative R3: Off-Line Storage .....28  
 Figure 5-1 Diversion Alternative 1 - Grated Trench .....29  
 Figure 5-2 Diversion Alternative 2 - Concrete Weirs .....30  
 Figure 5-3 Diversion Alternative 3 - Rubber Dam .....32  
 Figure 6-1 Comparing Discharge and LRS Flow Rates .....37  
 Figure 10-1 Treatment Alternative T1 Project Concept .....60  
 Figure 10-2 Treatment Alternative T2 Project Concept .....64  
 Figure 10-3 Treatment Alternative T3 Project Concept .....69  
 Figure 10-4 Injection Well Design .....70

## List of Tables

Table 3-1 Utilities at Alhambra Wash Site .....16  
 Table 3-2 Utilities at Eaton Wash Site .....18  
 Table 3-3 Utilities at Rubio Wash Site .....19  
 Table 4-1 LRS-Defined Peak Discharge Rate .....20



Table 5-1 Pros and Cons of Diversion Alternative 1 .....30

Table 5-2 Pros and Cons of Diversion Alternative 2 .....31

Table 5-3 Pros and Cons of Diversion Alternative 3 .....32

Table 5-4 Summary of Key Pump Components .....33

Table 5-5 Pros and Cons of In-Line Storage.....34

Table 5-6 Pros and Cons of Off-Line Subsurface Storage .....34

Table 6-1 LRS and Discharge Flow Rates.....36

Table 6-2 Analysis 1 Volume Summary .....38

Table 6-3 Analysis 2 Volume Summary with Storage .....39

Table 7-1 Summary of Anticipated O&M by Project Component .....40

Table 7-2 Sanitary Sewer Estimated Discharge Fees.....41

Table 7-3 Watermaster Potential Discharge Fees .....42

Table 8-1 Summary of Opinions of Probable Cost.....43

Table 8-2 Opinion of Probable Cost for Alhambra Wash Alternative A1 .....44

Table 8-3 Opinion of Probable Cost for Alhambra Wash Alternative A2 .....44

Table 8-4 Opinion of Probable Cost for Alhambra Wash Alternative A3 .....45

Table 8-5 Opinion of Probable Cost for Eaton Wash Alternative E1 .....45

Table 8-6 Opinion of Probable Cost for Eaton Wash Alternative E2.....46

Table 8-7 Opinion of Probable Cost for Rubio Wash Alternative R1.....47

Table 8-8 Opinion of Probable Cost for Rubio Wash Alternative R2.....47

Table 8-9 Opinion of Probable Cost for Rubio Wash Alternative R3.....48

Table 10-1 Similar Projects to Treatment Alternative T1 .....62

Table 10-2 Pros and Cons for Treatment Alternative T1.....63

Table 10-3 Similar Projects to Treatment Alternative T2 .....67

Table 10-4 Pros and Cons for Treatment Alternative T2.....68

Table 10-5 Pros and Cons for Treatment Alternative T2 – Centralized .....68

Table 10-6 Similar Projects to Treatment Alternative T3 .....72

Table 10-7 Pros and Cons for Treatment Alternative T3.....73

Table 10-8 Pros and Cons for Treatment Alternative T3 – Centralized .....74

Table 11-1 Project Recommendations .....75

Table 11-2 Opinion of Probable Cost for Alhambra Wash Recommended Alternative .....76

Table 11-3 Opinion of Probable Cost for Eaton Wash Recommended Alternative.....77

Table 11-4 Opinion of Probable Cost for Rubio Wash Recommended Alternative.....77

Table 11-5 Summary of Implementation Costs.....78



## Acronyms

APN	Assessor Parcel Number
bgs	Below ground surface
BMP	Best Management Practice
Caltrans	California Department of Transportation
CDFW	California Department of Fish and Wildlife
CFR	Code of Federal Regulations
cfs	Cubic feet per second
COD	Chemical Oxygen Demand
CWA	Clean Water Act
DSA	Division of State Architect
EWMP	Enhanced Watershed Management Program
GAC	Granulated Activated Carbon
gpm	Gallons per minute
HGL	Hydraulic Grade Line
JWPCP	Joint Water Pollution Control Plant
LACFCD	Los Angeles County Flood Control District
LACPW	Los Angeles County Public Works
LACSD	Los Angeles County Sanitation District
LADPH	Los Angeles Department of Public Health
LAR	Los Angeles River
LARWQCB	Los Angeles Regional Water Quality Control Board
LEL	Lower Explosive Limit
LRS	Load Reduction Strategy
MCM	Minimum Control Measure
MGD	Million gallons per day
MPN	Most Probable Number
MS4	Municipal Separate Storm Sewer System
NAVD	North American Vertical Datum
NOI	Notice of Intent
NPDES	National Pollutant Discharge Elimination System
NWP	Nationwide Permit
O&M	Operations and Maintenance
PCN	Pre-Construction Notification
RCB	Reinforced Concrete Box
RCP	Reinforced Concrete Pipe
SB	Senate Bill
SCADA	Supervisory Control and Data Acquisition
SCE	Southern California Edison
SGVCOG	San Gabriel Valley Council of Governments
TMDL	Total Maximum Daily Load
TSS	Total Suspended Solids

UIC	Underground Injection Control
ULAR	Upper Los Angeles River
USACE	United States Army Corp of Engineers
USEPA	United State Environmental Protection Agency
USFWS	United States Fish and Wildlife Services
USGVMWD	Upper San Gabriel Valley Municipal Water District
UV	Ultra Violet
VCP	Vitrified Clay Pipe
VFD	Variable Frequency Drive
WRP	Water Reclamation Plant
WSE	Water Surface Elevation



# 1. Background

The San Gabriel Valley Council of Governments (SGVCOG), on behalf of the County of Los Angeles (County) and the Cities of Alhambra, Monterey Park, Pasadena, Rosemead, San Gabriel, San Marino, South Pasadena, and Temple City is implementing the Load Reduction Strategy Projects for the Rio Hondo River and Tributaries (Project). The Project was identified in the *Rio Hondo Load Reduction Strategy: Addendum to Revise Implementation Actions for Alhambra Wash, Eaton Wash, and Rubio Wash* (referred to herein as the Rio Hondo LRS) (ULAR EWMP Group, 2017), an addendum to the *Rio Hondo Load Reduction Strategy for the Los Angeles River Watershed Bacteria TMDL* [Total Maximum Daily Load] (ULAR EWMP Group, et al., 2016).

The Project is proposed in response to the National Pollutant Discharge Elimination System (NPDES) Municipal Separate Storm Sewer System (MS4) Permit Order No. R4-2012-0175, which was adopted by the Los Angeles Regional Water Quality Control Board (LARWQCB) and enacted on December 28, 2012. The MS4 Permit identifies the permittees that are responsible for compliance with the MS4 Permit requirements pertaining to the Los Angeles River (LAR) Watershed Bacterial Total Maximum Daily Load (Bacteria TMDL) Resolution No. R10-007. The LAR Bacteria TMDL requires the responsible permittees to meet targets and waste load allocations for the indicator bacterium *E. coli* during wet-weather and dry-weather seasons. The LAR Bacteria TMDL further presents the Load Reduction Strategy (LRS) as a method for achieving compliance and was used to satisfy TMDL requirements.

The Cities of Alhambra, Monterey Park, Pasadena, Rosemead, San Gabriel, San Marino, South Pasadena, and Temple City, along with Unincorporated County have thus entered into an agreement with the SGVCOG to implement the Project to address the LAR Bacteria TMDL.

The Project consists of three low flow diversions along on Alhambra, Eaton, and Rubio Washes which will address dry-weather bacteria discharges from more than 35,000 acres of tributary area within the Upper Los Angeles River (ULAR) Enhanced Watershed Management Program (EWMP) Group area. Eight members of the ULAR EWMP Group (Alhambra, Monterey Park, Pasadena, Rosemead, San Gabriel, San Marino, South Pasadena, and Temple City –referred to as Cities), along with portions of Unincorporated County, contribute to flows that will be captured by the Project. **Figure 1-1** below illustrates the three Project sites and their associated drainage areas.

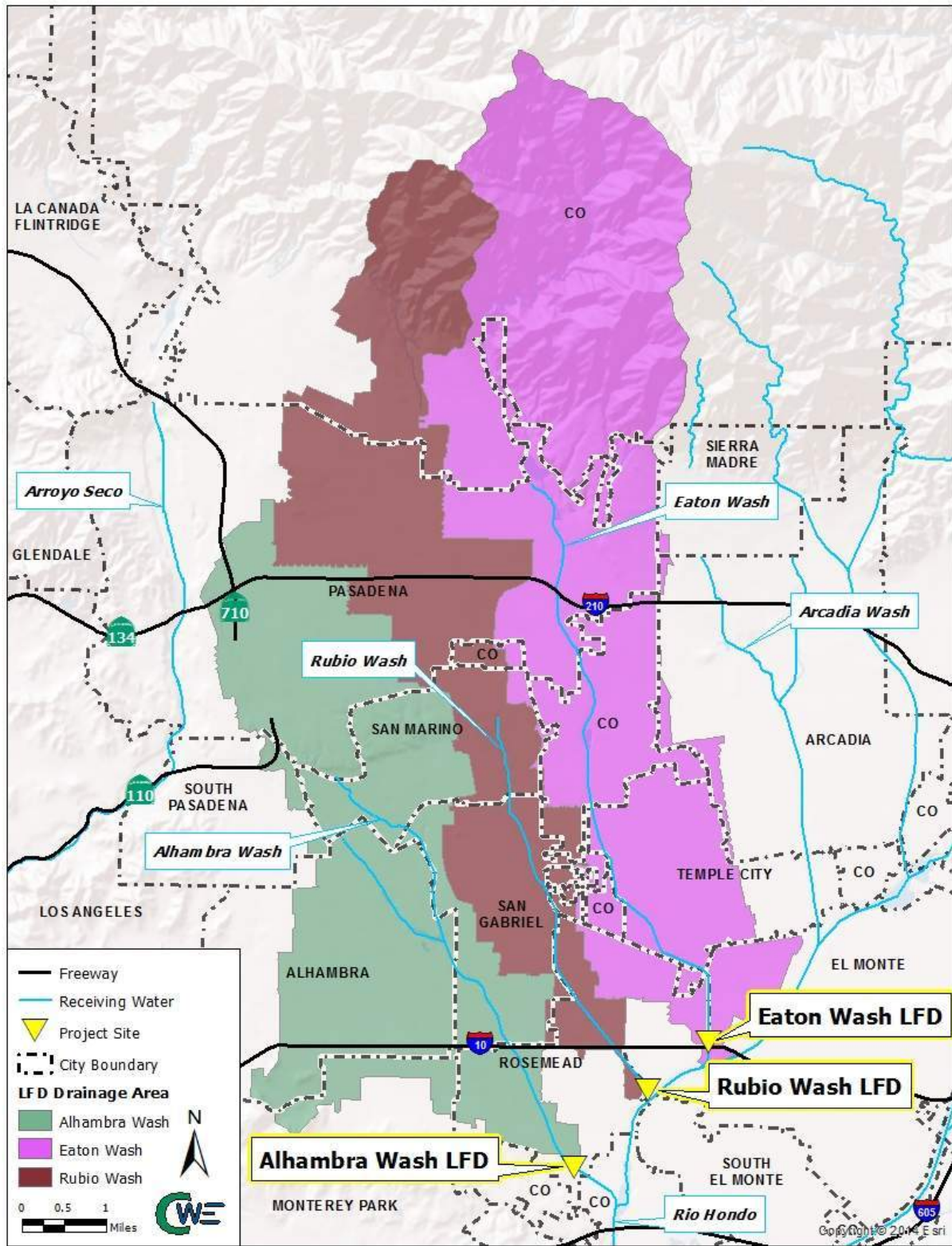
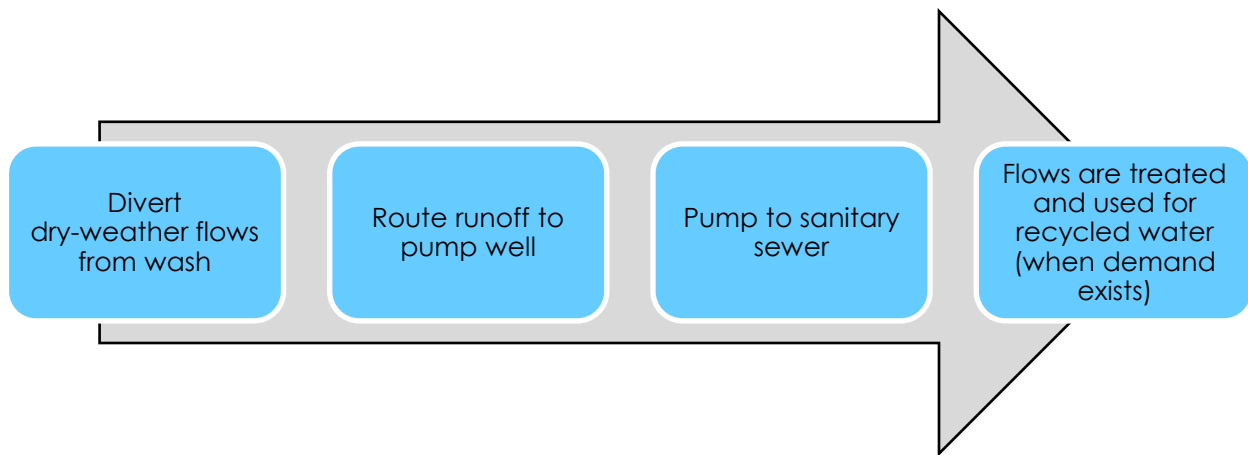

Figure 1-1 Project Sites

## 2. Project Purpose and Goals

The Project is being implemented to meet water quality goals as identified in the Rio Hondo LRS and as required by the MS4 Permit. Opportunities to achieve multiple benefits will be evaluated, such as water conservation and community benefits. The Project will address dry-weather discharges into Alhambra, Eaton, and Rubio Wash from the portions of the Cities that are tributary to the Rio Hondo, as illustrated in **Figure 1-1**. **Figure 2-1** illustrates the general concept of the Project identified in the LRS. The Project will reduce pollutant loading to downstream water bodies by diverting dry-weather runoff, including bacteria. The diversion system will be designed in such a way that will minimize the amount of trash and debris diverted from the channel into the Project. Under the LRS concept, diverted flows would be directed into a pump well and pumped to an existing sewer line owned by the Los Angeles County Sanitation Districts (LACSD). Flows will ultimately be treated at an existing treatment facility before being used to meet local recycled water demands when demands exist.



**Figure 2-1 General LRS Project Concept**

This Feasibility Assessment Report focuses on the LRS Project concept (as illustrated in the figure above), which includes diverting dry-weather flows to the sanitary sewer. The goals and objectives of the LRS Project, which include reducing bacteria loading to the Rio Hondo, remain a priority. The Cities raised some concerns regarding the LRS approach, which are further summarized in **Section 10**. In response to these concerns, additional alternatives to meeting the LRS objectives were identified and evaluated.

Project goals are summarized as follows:

- Enhance water quality locally and in downstream water bodies
- Reduce bacteria loading and contribute towards meeting LAR Bacteria TMDL targets (LRS objective)
- Provide benefits in addition to water quality (water conservation and/or community benefits)

This Feasibility Assessment Report aims to achieve the following goals:

- Document existing conditions that impact Project design and implementation
- Describe Project hydrology that will influence component sizing
- Present concepts based on the LRS approach to be considered for implementation
- Identify permits and approvals required prior to Project implementation (based on the LRS approach)
- Evaluate alternatives to the LRS approach that will achieve the objectives of the LRS
- Provide recommendations to move forward into final design

## 3. Existing Conditions

This section describes the existing conditions of the three Project sites (Alhambra, Eaton, and Rubio Washes), including the site location, topography, soil conditions, and utilities. The existing conditions are described in general, as they impact the Project design elements. This section describes existing conditions in the vicinity of the channels, in alignment with the LRS approach.

### 3.1 Site Location

Alhambra, Eaton, and Rubio Wash are all concrete-lined rectangular channels owned and maintained by the Los Angeles County Flood Control District (LACFCD). The following sections describe the locations of each of the sites.

#### 3.1.1 Alhambra Wash

The Alhambra Wash site, presented in **Figure 3-1**, is located in the City of Rosemead, near the intersection of Rush Street and Walnut Grove Avenue near the southern end of the City. The Project site is located near Rice Elementary School and a Walmart Supercenter. Coordination and additional planning will be required to minimize impacts to these facilities during construction. The Project site delineation shown below includes the diversion and original sewer connection, which was expected to be located near the intersection of Rush Street and Angelus Avenue. Following coordination with LACSD, it was determined that the sewer connection would need to be located on Klingerman Street on the east side of Alhambra Wash, as indicated in **Section 4**. The boundary shown below, and throughout this section, was not revised based on the sewer connection location, as the boundary illustrated represents the Project site used to collect topography, geotechnical data, and utility information, each of which are further detailed in **Section 3**. Explorations will need to be expanded if the design approach detailed in **Section 4** represents the final design approach.

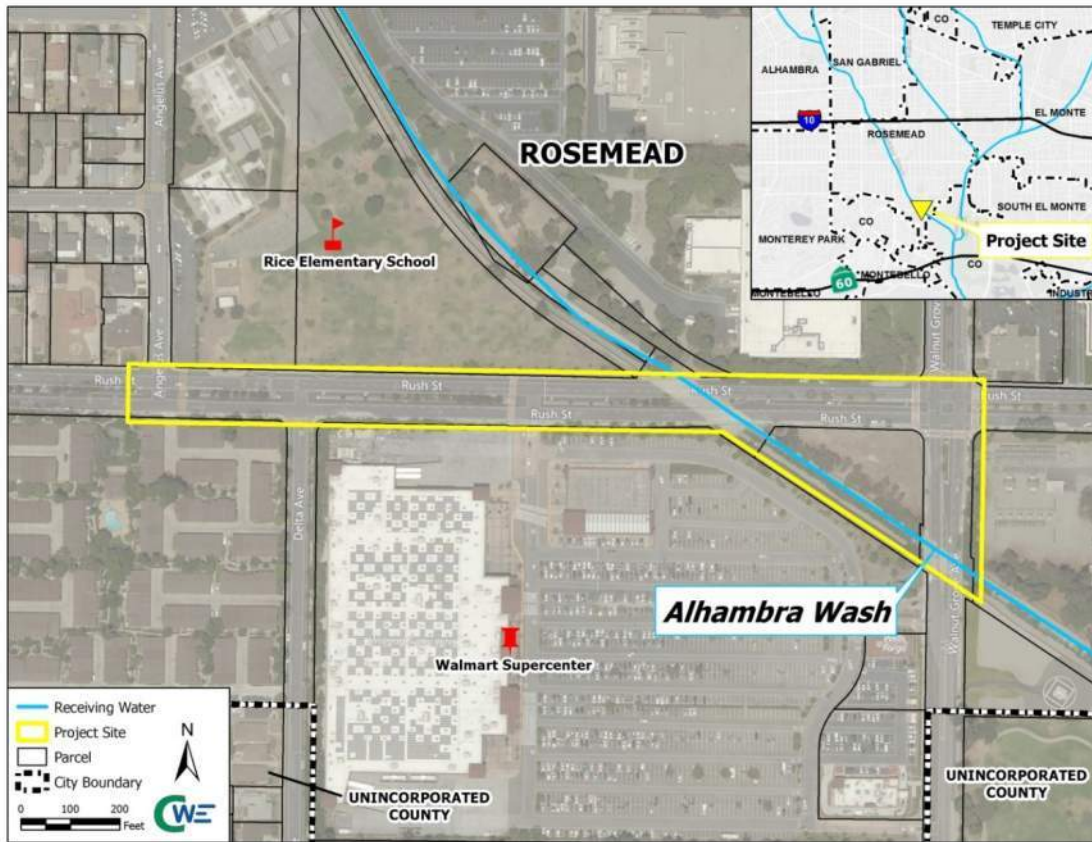

Figure 3-1 Alhambra Wash Site Location

### 3.1.2 Eaton Wash

The Eaton Wash site, presented in **Figure 3-2**, is located in the City of El Monte, just north of the Interstate 10 overpass at Eaton Wash. The LACFCO right-of-way near the Project widens for a short distance. This extra space will be utilized for proposed components. The Project site delineation shown below includes the diversion and sewer connection, which are further discussed in **Section 4**.



**Figure 3-2 Eaton Wash Site Location**

### 3.1.3 Rubio Wash

The Rubio Wash site, presented in **Figure 3-3**, is also located in the City of El Monte, near the Rosemead Boulevard overpass at the Rio Hondo, approximately 1,000 feet northwest of the Rosemead Boulevard and Garvey Avenue intersection. The parcel adjacent to the channel, along with the parcel that contains this segment of the channel, are privately owned. Additionally, Rosemead Boulevard is owned and operated by the California Department of Transportation (Caltrans). The Project site delineation shown below includes the diversion and sewer connection, which are further discussed in **Section 4**.

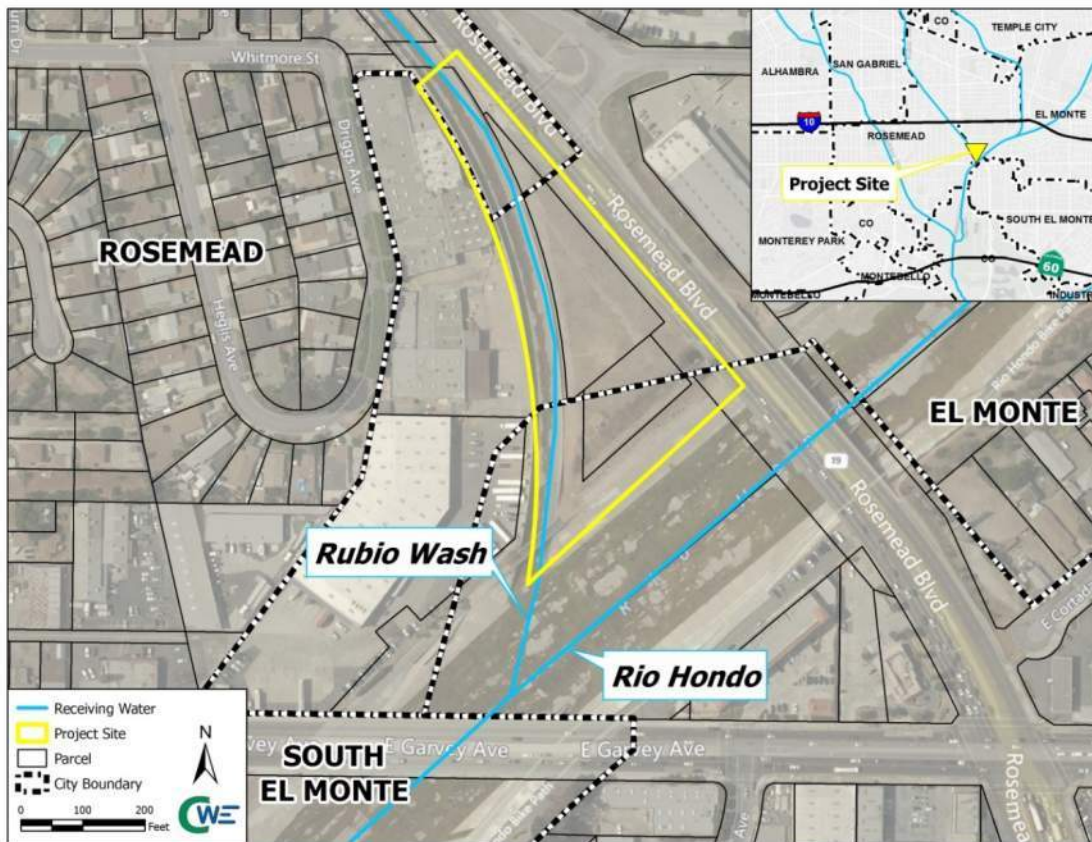

**Figure 3-3 Rubio Wash Site Location**

## 3.2 Topography

A field survey for each Project site was conducted in November 2018. The following sections detail the survey's topographic findings for the sites at Alhambra, Eaton, and Rubio Wash. The topographic survey was performed using North American Vertical Datum of 1988 (NAVD 88) and North American Horizontal Datum of 1983.

### 3.2.1 Alhambra Wash

Approximately 6 acres was surveyed at the Alhambra Wash site and is comprised primarily of public right-of-way and flood control uses, except the parcel east of the channel, which is owned by Southern California Edison (SCE). Additional survey may be required prior to final design, as the proposed sewer connection will be located near Angelus Avenue, which was not what was originally anticipated.

The topography of the portion of Project site under which the diversion line is proposed (Rush Street) is relatively flat with graded slopes of less than 1%, as presented in **Figure 3-4** below, with a detailed base map included in **Appendix A**. The slope of the concrete-lined Alhambra Wash was confirmed to be 0.5%, consistent with what is shown on the as-built plans. The survey area may need to expand based on the final design approach, as indicated in **Section 3.1.1**.



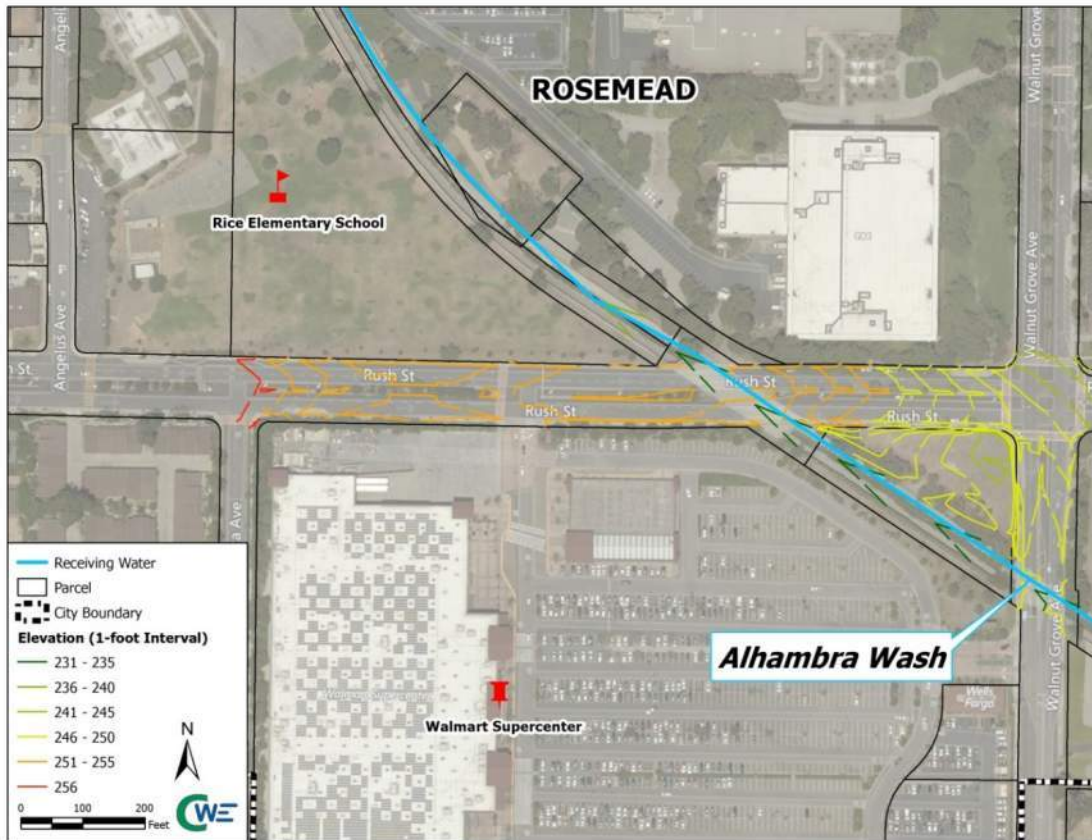

Figure 3-4 Alhambra Wash Site Topography

### 3.2.2 Eaton Wash

Less than an acre was surveyed at the Eaton Wash site and is comprised primarily of Eaton Wash and LACFCD right-of-way. Permanent improvements are proposed within Eaton Wash and the adjacent access road on the eastern side of the channel.

As shown in **Figure 3-5**, the topography of the land under which the diversion line is proposed varies with slopes ranging from less than 1% along most of the right-of-way to 38% just beside the highway overpass. The slope of the concrete-lined Eaton Wash was confirmed to be 0.5% as shown on the as-built plans. A detailed base map included in **Appendix A**.



Figure 3-5 Eaton Wash Site Topography

### 3.2.3 Rubio Wash

Approximately three acres was surveyed at the Rubio Wash site and is comprised primarily solely of Rubio Wash and private property. Permanent improvements are proposed within Rubio Wash and the adjacent parcel, both of which are privately owned.

As shown in **Figure 3-6**, the topography of the land under which the diversion line is proposed is relatively flat with a slope of less than 1% running parallel to Rosemead Boulevard and a slope 2% running perpendicular to it. The slope of the concrete-lined Rubio Wash was confirmed to be 0.5% as shown on the as-built plans. A detailed base map included in **Appendix A**.

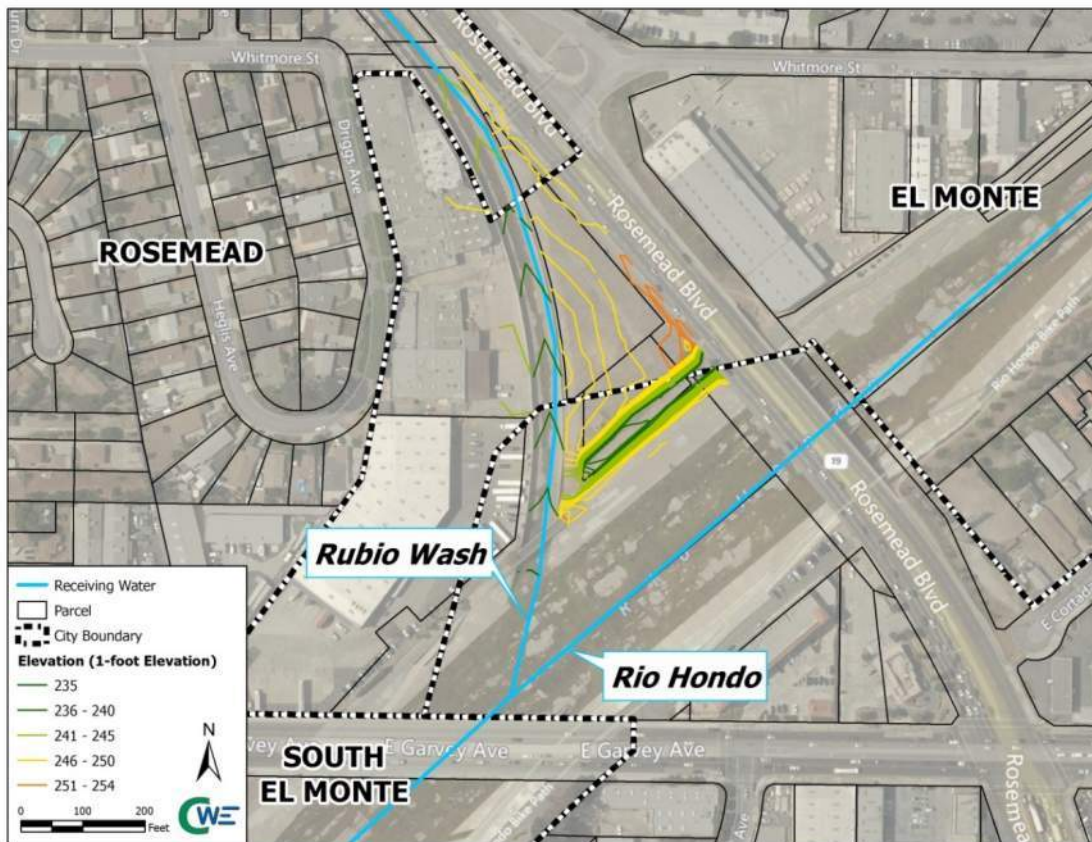

Figure 3-6 Rubio Wash Site Topography

### 3.3 Geotechnical

A geotechnical engineering analysis was performed by Terracon Consultants, Inc. for the Project in February 2019. The resulting report, *Geotechnical Engineering Report: SGVGOC ACE Rio Hondo Load Reduction Strategy Design Project*, summarizes the geotechnical findings, considerations, and recommendations relevant to the Project. The Geotechnical Report is included in **Appendix B** of this report. The following sections summarize soil characteristics for the sites at Alhambra, Eaton, and Rubio Wash.

#### 3.3.1 Alhambra Wash

Four test borings and one percolation boring were performed at the Alhambra Wash site, as shown in **Figure 3-7**. Test borings were drilled to approximate depths of 10 to 51.5 feet below ground surface (bgs). The percolation boring was drilled to an approximate depth of 25 feet bgs. The deep boring was used to determine if there is a potential for liquefaction on site, as the area is shown to have liquefaction potential in existing hazard maps. Additional borings may be required based on the final design approach, as indicated in **Section 3.1.1**.



**Figure 3-7 Boring Sites at Alhambra Wash**

Soil types encountered in the borings consisted predominantly of interbedded loose to dense sand with variable amounts of gravel, silt and clay, and medium-stiff to very stiff clay with variable amounts of sand to the maximum depth explored of about 50 feet bgs.

A single percolation test was performed at the Alhambra Wash site and found a minimum measured uncorrected percolation rate of 1.7 inches per hour (in/hr), which equates to a corrected infiltration rate of 0.11 in/hr. The infiltration rate is less than 0.3 in/hr, the required threshold from the Los Angeles County Public Works (LACPW) Geotechnical and Materials Engineering Division *Guidelines for Design, Investigation, and Reporting Low Impact Development Stormwater Infiltration* (2014). The percolation test demonstrates that onsite infiltration is infeasible.

Groundwater was not encountered in any of the borings. Based on the LACPW Historical Well Measurement Data, the historic high groundwater depth is 193 feet above mean sea level which corresponds to an approximate depth of 50 feet bgs at the site.

The Project is located within a liquefaction potential hazard zone as indicated by the California Geological Survey. A liquefaction analysis was performed for the Project site based on soils data from boring BA-1. Accepted methodology and software were utilized in the analysis with groundwater assumed at 50 feet bgs based upon the conservative historical high groundwater. The results indicate that the liquefaction hazard potential is considered medium to high with a seismically-induced total saturated and dry sand settlement of 1.8 inches. If the liquefaction potential is high, infiltration is not recommended. Infiltration

was deemed infeasible due to low rates; therefore, the Project will not contribute to liquefaction potential through infiltration.

The site excavation for the installation of the diversion structure and pump well will require a vertical cut excavation deeper than five feet, which will require shoring or bracing. Open trench excavation is expected along Rush Street for placement of the diversion line. Slope stability is addressed in the geotechnical report as well as shoring design recommendations. The geotechnical investigation addresses the design parameters required for shoring design and lateral pressures for the pump well. Additional soil characteristics and recommendations are included in the Geotechnical Report included in **Appendix B**.

### 3.3.2 Eaton Wash

Two test borings and one percolation boring were performed at the Eaton Wash site, as shown in **Figure 3-8**. Test borings were drilled to approximate depths of 26.5 to 51.5 feet bgs. The percolation boring was drilled to an approximate depth of 25 feet bgs.

Soil types encountered in the borings consisted of predominantly loose to dense sand with variable amounts of silt to the maximum depth explored of about 50 feet bgs. A layer of silt with variable amounts of sand was encountered between the depths of 7.5 and 25 feet bgs.

A single percolation test was performed at the Eaton Wash site and found a minimum measured uncorrected percolation rate of 1.0 inches per hour (in/hr), which equates to a corrected infiltration rate of 0.06 in/hr. The infiltration rate is less than 0.3 in/hr, which demonstrates that onsite infiltration is infeasible, as discussed in the subsection above.

Groundwater was not encountered in any of the borings. Based on the LACPW Historical Well Measurement Data, the historic high groundwater depth is 235 feet above mean sea level which corresponds to an approximate depth of 28 feet bgs at the site.

The Project is located within a liquefaction potential hazard zone as indicated by the California Geological Survey. A liquefaction analysis was performed for the Project site based on soils data from boring BE-1. Accepted methodology and software were utilized in the analysis with groundwater assumed at 28 feet bgs based upon the conservative historical high groundwater. The results indicate that the liquefaction hazard potential is considered medium to high with a seismically-induced total saturated and dry sand settlement of 3.1 inches. If the liquefaction potential is high, infiltration is not recommended. Infiltration was deemed infeasible due to low rates; therefore, the Project will not contribute to liquefaction potential through infiltration.



**Figure 3-8 Boring Sites at Eaton Wash**

The site excavation for the installation of the diversion structure and pump well will require a vertical cut excavation deeper than five feet, which will require shoring or bracing. Open trench excavation is expected within the LACFCD right-of-way for placement of the diversion line. Slope stability is addressed in the geotechnical report as well as shoring design recommendations. The geotechnical investigation addresses the design parameters required for shoring design and lateral pressures for the pump well. Additional soil characteristics and recommendations are included in the Geotechnical Report included in **Appendix B**.

### 3.3.3 Rubio Wash

Two test borings and one percolation boring were performed at the Rubio Wash site, as shown in **Figure 3-9**. Test borings were drilled to approximate depths of 26.5 to 51.5 feet bgs. The percolation boring was drilled to an approximate depth of 25 feet bgs.

An undocumented fill, comprised of sand with variable amounts of silt and clay, was encountered depths of 12 to 15 feet bgs. Below that, soil types consisted of predominantly loose to dense sand with variable amounts of silt and clay to the maximum depth explored of about 50 feet bgs. A soft to medium stiff silty clay with variable amounts of sand was encountered between 25 and 35 feet bgs. Fill material was found at depths deeper than 15 feet. Documentation indicating if placement of this fill was monitored during placement is unaccounted for. Low field blow counts indicate that the fill may not have received adequate compaction during placement.

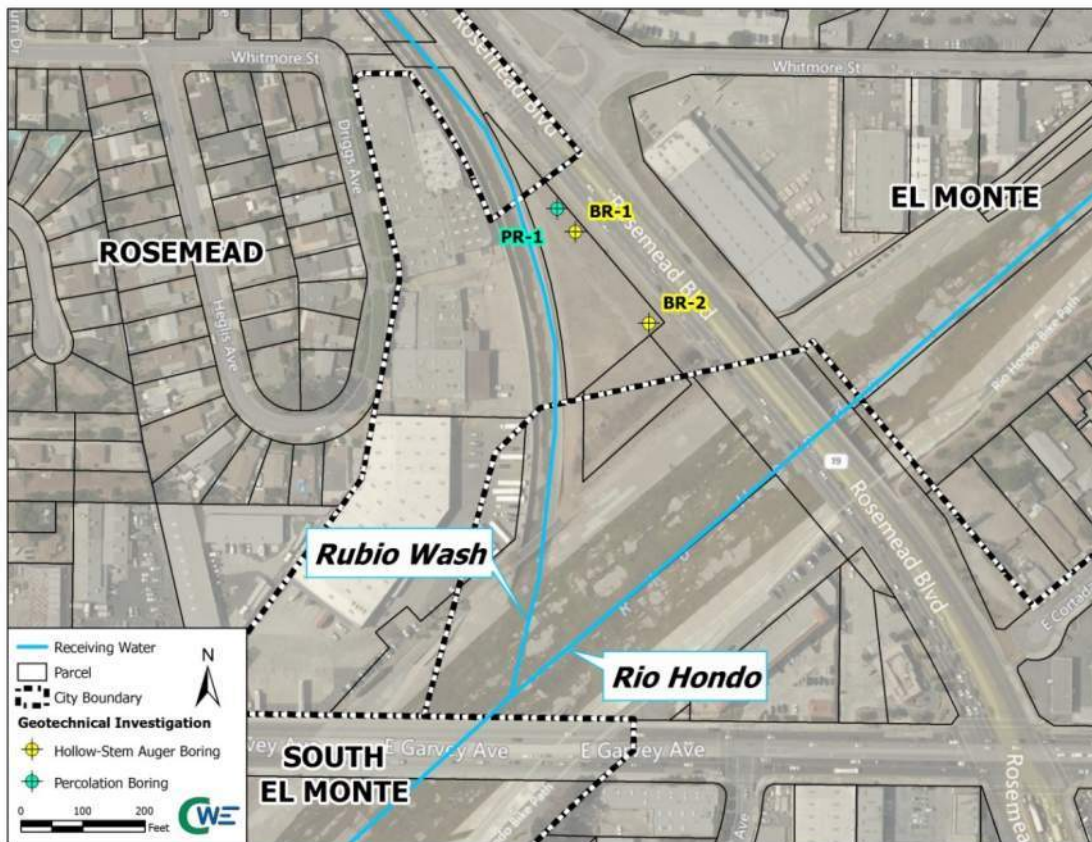

**Figure 3-9 Boring Sites at Rubio Wash**

A single percolation test was performed at the Rubio Wash site and found a minimum measured uncorrected percolation rate of 0.7 inches per hour (in/hr), which equates to a corrected infiltration rate of 0.09 in/hr. The measured infiltration rate is less than 0.3 in/hr which demonstrates that onsite infiltration is infeasible, as described in the previous subsections.

Groundwater was not encountered in any of the borings. Based on the LACPW Historical Well Measurement Data, the historic high groundwater depth is 225 feet above mean sea level which corresponds to an approximate depth of 25 feet bgs at the site.

The Project is located within a liquefaction potential hazard zone as indicated by the California Geological Survey. A liquefaction analysis was performed for the Project site based on soils data from boring BR-1. Accepted methodology and software were utilized in the analysis with groundwater assumed at 25 feet bgs based upon the conservative historical high groundwater. The results indicate that the liquefaction hazard potential is considered medium to high with a seismically-induced total saturated and dry sand settlement of 6.1 inches. If the liquefaction potential is high, infiltration is not recommended. Infiltration was deemed infeasible due to low rates; therefore, the Project will not contribute to liquefaction potential through infiltration.

The site excavation for the installation of the diversion structure and pump well will require a vertical cut excavation deeper than five feet, which will require shoring or bracing. Open trench excavation is expected within the adjacent parcel for placement of the diversion line. Slope stability is addressed in the geotechnical report as well as shoring design recommendations. The geotechnical investigation addresses the design parameters required for shoring design and lateral pressures for the pump well. Additional soil characteristics and recommendations are included in the Geotechnical Report included in **Appendix B**.

### 3.4 Utilities

A utility search was performed to determine the existing utilities in and around the sites at Alhambra, Eaton, and Rubio Wash. Underground Service Alert (DigAlert) was used to identify potential utility owners within the Project area and Preliminary Utility Search Notices were sent to the potential owners identified. The utility search will be ongoing throughout the design process. A review of utility information collected shows minimal intrusion within LACFCD right-of-way; however, several private-, city-, and county-owned utility lines exist within the public right-of-way and adjacent private property that must be considered during the design process and avoided when possible. The following sections detail the utility findings for each of the sites. A utility contact log and available utility maps are included in **Appendix C**. The utility lines shown in the figures below and throughout this Report were provided by the utility owners. Design plans may differ slightly in comparison to what is shown based on more detailed utility research.

#### 3.4.1 Alhambra Wash

Several gas, electrical, and water facilities are present along Rush Street, along the anticipated diversion pipe alignment. Three sewer lines are also present at the Project site: an 8-inch Vitrified Clay Pipe (VCP) that runs along Rush Street, a 15-inch VCP that runs along Angelus Avenue, and a 27-inch VCP that runs along Delta Avenue and crosses Rush Street. Additionally, there is an 8.5-foot wide by 6-foot high Reinforced Concrete Box (RCB) storm drain that runs along Rush Street. **Table 3-1** summarizes the utility information obtained as of the date of this Report for the Project site shown in **Figure 3-1**. The utility search limits may need to expand based on the final design approach, as indicated in **Section 3.1.1**. Recycled water, sewer, storm drain, and water line alignments within the limits of proposed work are illustrated in **Figure 3-10**.

**Table 3-1 Utilities at Alhambra Wash Site**

Utility Type	Owner	Size	Location
Electrical	SCE	Various	Along Rush Street
Gas	Southern California Gas	3-inch	Along Rush Street
		2-inch	Along Delta Avenue
Reclaimed Water	San Gabriel Valley Water Company	6-inch	Along Rush Street
Sewer	LACSD	8-inch	Along Rush Street
		15-inch	Along Angelus Avenue
		27-inch	Along Delta Avenue and crossing Rush Street
Telecom	Charter	4-inch	Requires field investigation



Utility Type	Owner	Size	Location
Water	San Gabriel Valley Water Company	16-inch	Along Rush Street
		16-inch	Along Delta Avenue
		8-inch	Along Delta Avenue

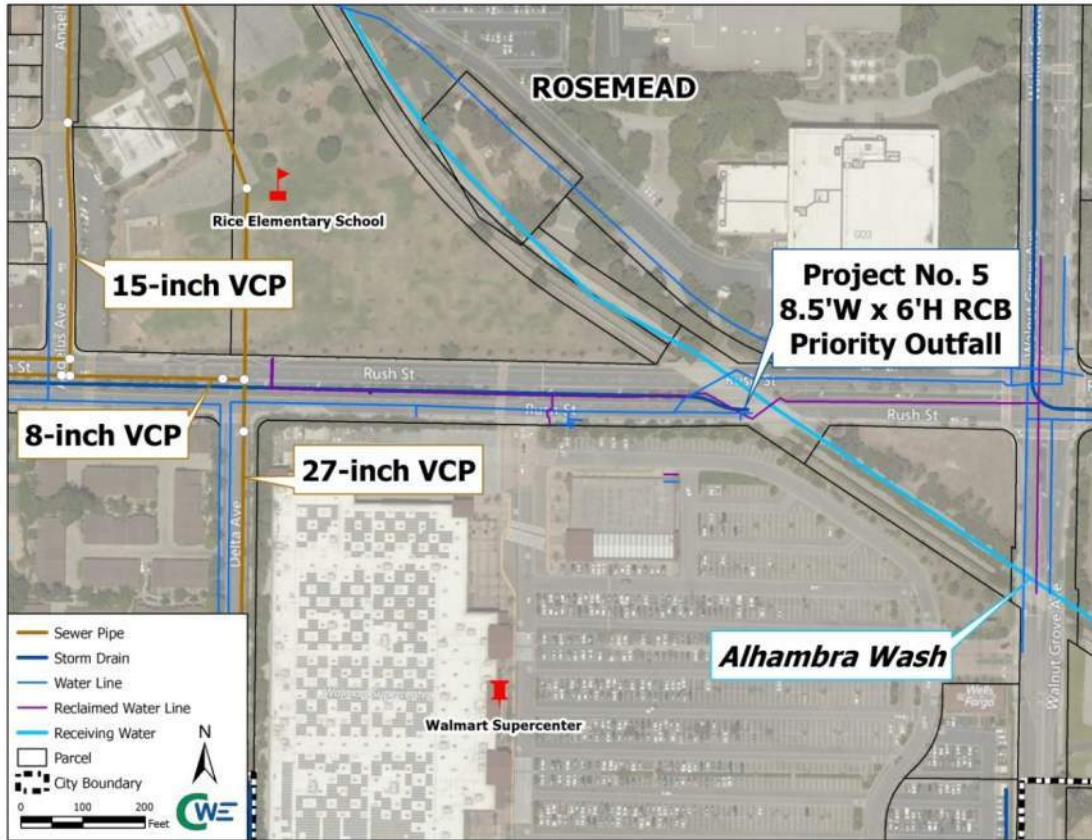

Figure 3-10 Utilities at Alhambra Wash

### 3.4.2 Eaton Wash

Few facilities are present at the Eaton Wash site. A 36-inch Reinforced Concrete Pipe (RCP) sewer line crosses Eaton Wash just north of Interstate 10 as two 24-inch RCP siphons. A manhole is located on each side of the sewer siphon. Underground and overhead electrical facilities are also present along the edge of the channel near Interstate 10. **Table 3-2** summarizes the utility information obtained as of the date of this Report. Sewer line alignments within the limits of proposed work are illustrated in **Figure 3-11**.

**Table 3-2 Utilities at Eaton Wash Site**

Utility Type	Owner	Size	Location
Electrical	SCE	Various	Along edge of channel (overhead and underground)
Sewer	LACSD	36-inch	Upstream and downstream of siphon crossing Eaton Wash
	LACSD	24-inch	Two siphons that cross Eaton Wash



**Figure 3-11 Utilities at Eaton Wash**

### 3.4.3 Rubio Wash

Minimal utilities were found at the Rubio Wash site, which seems reasonable, as the site involves an undeveloped private parcel. A 57-inch RCP sewer line crosses the parcel adjacent to the channel on which Project components are proposed. **Table 3-3** summarizes the utility information obtained as of the date of this Report. A 42-inch RCP sewer line crosses Rubio Wash north of the site and will be avoided. The sewer utilities are owned and operated by LACSD. Sewer line alignments within the limits of proposed work are illustrated in **Figure 3-12**. The utility search did not extend onto Rosemead Boulevard, as it is Caltrans right-of-way and will be avoided.

**Table 3-3 Utilities at Rubio Wash Site**

Utility Type	Owner	Size	Location
Sewer	LACSD	57-inch	Within parcel adjacent to Rubio Wash

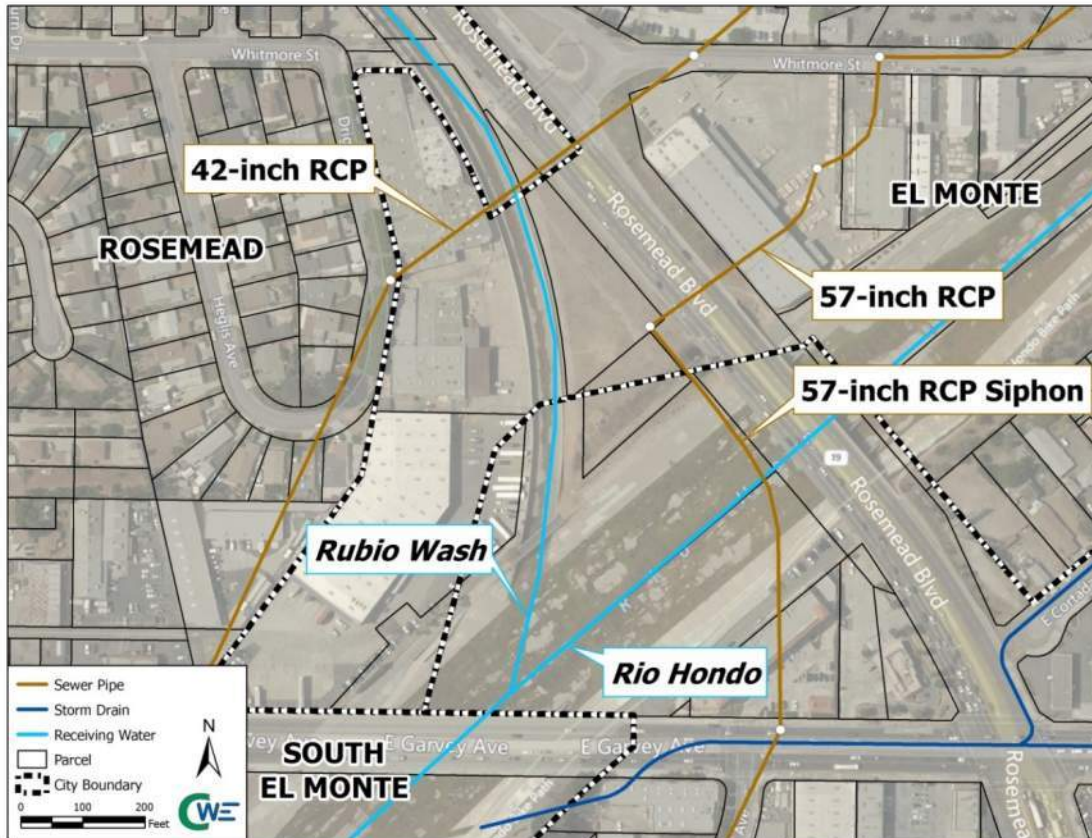

**Figure 3-12 Utilities at Rubio Wash**

## 4. Proposed Improvements

To meet the goals discussed in **Section 2**, three dry-weather low flow diversions were proposed in the LRS, one at each wash. Three alternatives were evaluated for the Alhambra and Rubio Wash sites, and two for the Eaton Wash site. The alternatives represent different approaches that can be used to meet the objectives of the Rio Hondo LRS using the LRS approach (diversion to sanitary sewer). The Rio Hondo LRS was approved by the LARWQCB and is now part of the recipe for achieving compliance within Rio Hondo and its tributaries. The LRS identified the peak dry-weather discharge rate that is to be diverted from the washes to the sanitary sewer to meet the goals of the LAR Bacteria TMDL during dry-weather. Peak discharge rates are summarized in gallons per minute (gpm) and cubic feet per second (cfs) in **Table 4-1** below. A flow analysis was performed to identify discharge alternatives that would provide the same or better outcome as what was approved in the LRS. The flow analysis approach and results are summarized in **Section 6**. This section describes the preliminary layout and sizing for each of the alternatives. Preliminary drawings are included as **Appendix D**. Details regarding the components mentioned in this section are included in **Section 5**.

**Table 4-1 LRS-Defined Peak Discharge Rate**

Site	LRS-Defined Peak Discharge Rate	
	(gpm)	(cfs)
Alhambra Wash	1,000	2.23
Eaton Wash	630	1.40
Rubio Wash	800	1.78

### 4.1 Alhambra Wash

Three alternative approaches for diverting dry-weather flows to the sanitary sewer were evaluated for Alhambra Wash, which are detailed in the following subsections and listed below:

1. Low flow diversion with no storage and the LRS-defined discharge rate
2. Low flow diversion with in-line storage with optimized discharge rates
3. Low flow diversion with off-line storage with optimized discharge rates

Additional preliminary site assessments, such as those summarized in **Section 3**, may need to be updated as part of the final design process based on the sewer connection location illustrated in the following alternatives, as is indicated in **Section 3.1.1**.

#### 4.1.1 Alhambra Wash Alternative A1: No Storage

Alhambra Wash Alternative A1 includes a low flow diversion with no storage component and a discharge rate equal to the LRS-defined discharge rate (1,000 gpm), as indicated in **Table 4-1**. Low flows will be diverted from Alhambra Wash via Diversion Alternative 1 or Diversion Alternative 2, as discussed in **Section 5**. Flows will be conveyed to a pump well and discharged into the 39-inch VCP sewer line on Klingerman Street on the east side of Alhambra Wash. The pipe is almost half a mile long. The sewer line is owned and maintained by LACSD. The sewer connection must be made at this location, as it conveys flows to the Whittier Narrows (WRP) and has sufficient capacity. The other sewer pipes in the

Project vicinity bypass the reclamation plant. Further coordination with LACSD to determine if the sewer connection could be closer to the diversion would be beneficial based on the discussion in **Section 10**, as flows conveyed to the Whittier Narrows WRP may bypass to a downstream treatment plant; therefore, it may be acceptable to discharge into a system that does not convey flows to the Whittier Narrows WRP.

**Figure 4-1** below, shows the preliminary site layout for Alhambra Wash Alternative A1. Preliminary design plans are included in **Appendix D**.

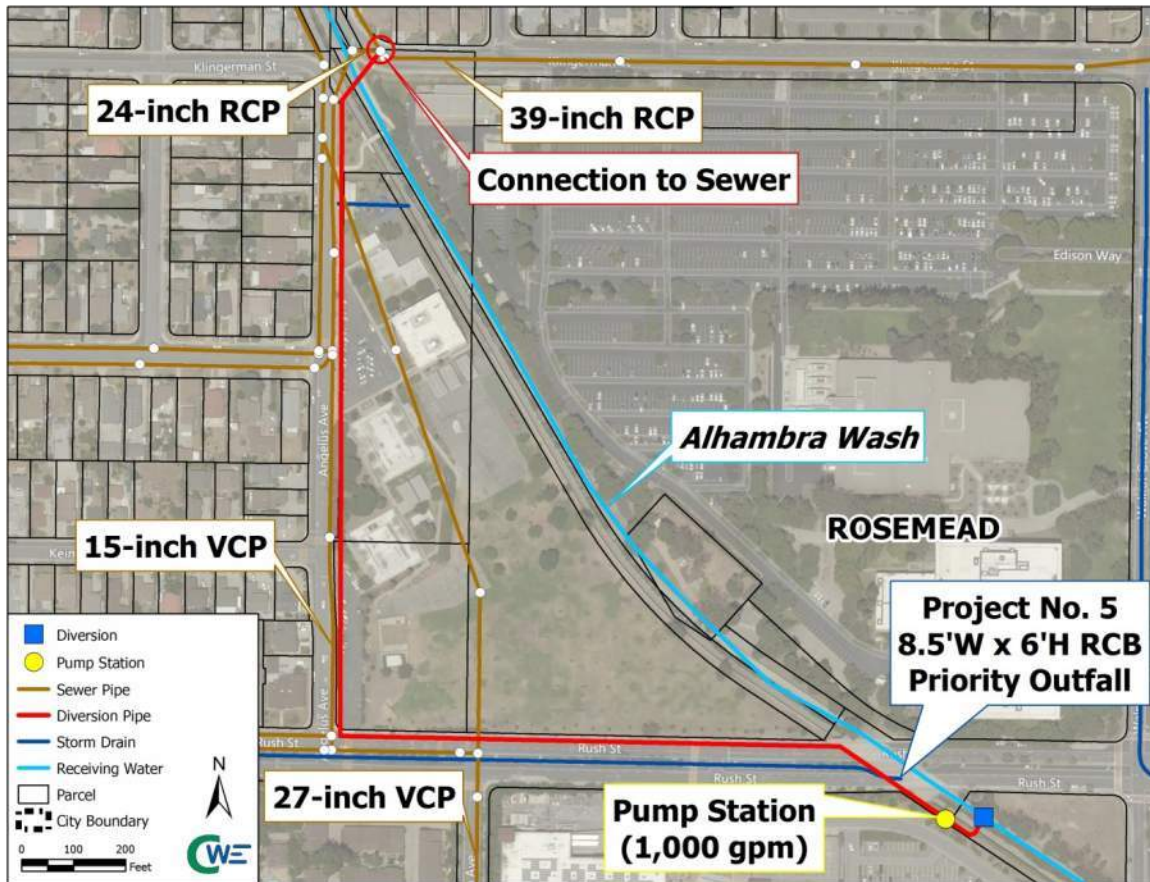

**Figure 4-1 Alhambra Wash Alternative A1: No Storage**

#### 4.1.2 Alhambra Wash Alternative A2: In-Line Storage

Alhambra Wash Alternative A2 includes a low flow diversion with an in-line storage component and optimized daytime and nighttime discharge rates. A rubber dam (Diversion Alternative 3) will be used to divert flows and also provide storage within the channel, up to a volume of 2.05 acre-feet, as discussed in **Section 5** and **Section 6**. Diverted flows will be conveyed to a pump well and discharged into the sewer consistent with Alternative A1. Flows will discharge at an optimized peak rate of 767 gpm during the day and 1,200 gpm during the night, per the analysis in **Section 6**. **Figure 4-2** illustrates the preliminary layout for Alternative A2. The in-line storage extent is shown with a cross hatch pattern, while this is not representative of a new structure. Preliminary design plans are included in **Appendix D**.

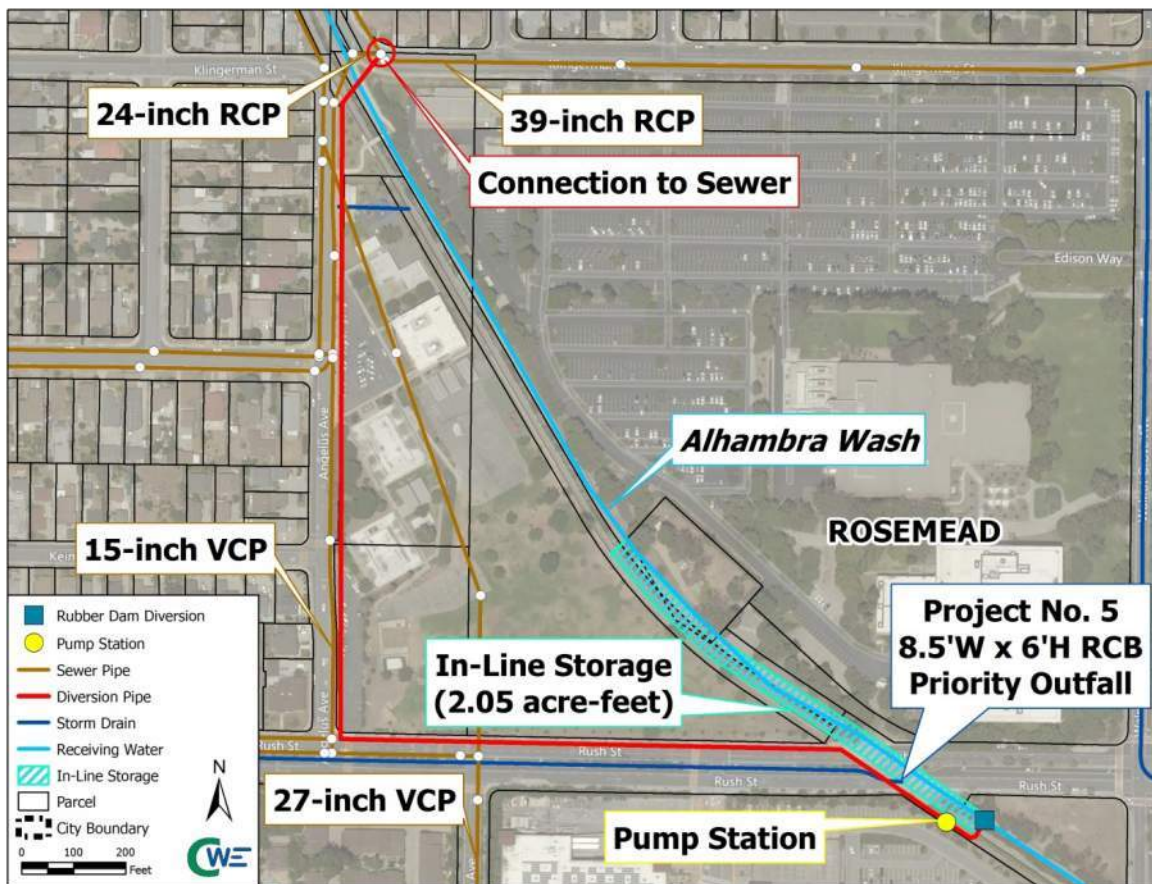

Figure 4-2 Alhambra Wash Alternative A2: In-Line Storage

#### 4.1.3 Alhambra Wash Alternative A3: Off-Line Storage

Alhambra Wash Alternative A3 includes a low flow diversion with an off-line storage component and optimized daytime and nighttime discharge rates. Low flows will be diverted from Alhambra Wash via Diversion Alternative 1 or Diversion Alternative 2, as discussed in **Section 5**, and stored in a subsurface storage structure that is proposed within the parcel adjacent to the left bank of the channel, which is owned by SCE. The storage structure will have a design capture volume of 2.05 acre-feet, consistent with Alternative A2 and based on the analysis described in **Section 6**. Stored flows will be conveyed to a pump well and discharged into the sewer using the same layout as the previously discussed alternatives. The optimized daytime and nighttime discharge rates will be the same as Alternative A2, 767 and 1,200 gpm, respectively. **Figure 4-3** illustrates the preliminary site layout for Alternative A3. Preliminary design plans are included in **Appendix D**.

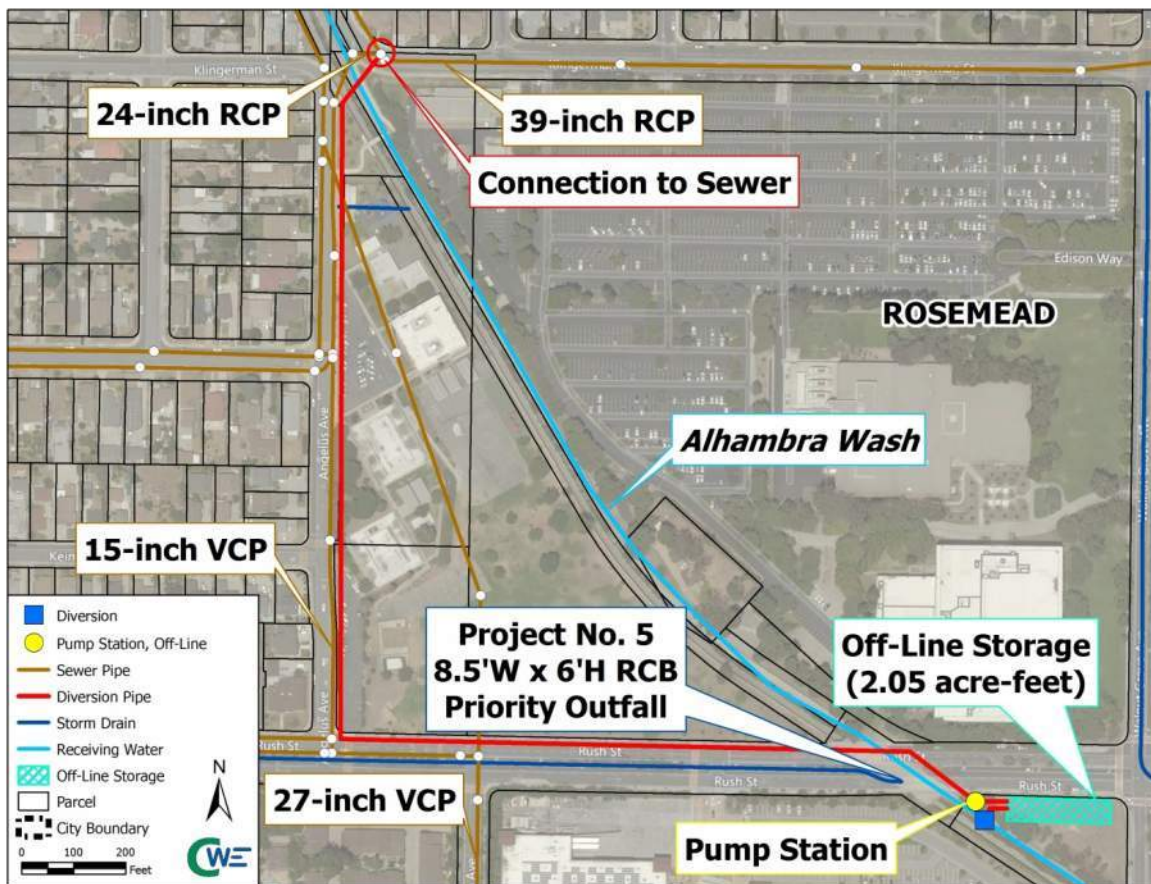

Figure 4-3 Alhambra Wash Alternative A3: Off-Line Storage

## 4.2 Eaton Wash

The following two alternatives for diverting dry-weather flows to the sanitary sewer were evaluated for Eaton Wash, which are described further in the following subsections:

1. Low flow diversion with no storage and the LRS-defined discharge rate
2. Low flow diversion with in-line storage with optimized discharge rates

### 4.2.1 Eaton Wash Alternative E1: No Storage

Eaton Wash Alternative E1 includes a low flow diversion with no storage component and a discharge rate equal to the LRS-defined discharge rate (630 gpm), as indicated in **Table 4-1**. Low flows will be diverted from Eaton Wash via Diversion Alternative 1 or Diversion Alternative 2, as discussed in **Section 5**. Flows will be conveyed to a pump well and discharged into a manhole on an 8-inch line owned by the City of El Monte, which services the adjacent mobile home park. The 8-inch sewer connects to a 36-inch RCP sewer line just south of the Project, which then connects to two 24-inch RCP siphons that crosses Eaton Wash just north of Interstate 10. The 36-inch and 24-inch sewer lines are owned and maintained by LACSD. LACSD requested the connection be made at the 8-inch line due to the siphon configuration. The connection may be located outside of LACFCD right-of-way, in which case

an easement will be required. **Figure 4-4** illustrates the preliminary site layout for Alternative E1. Preliminary design plans are included in **Appendix D**.

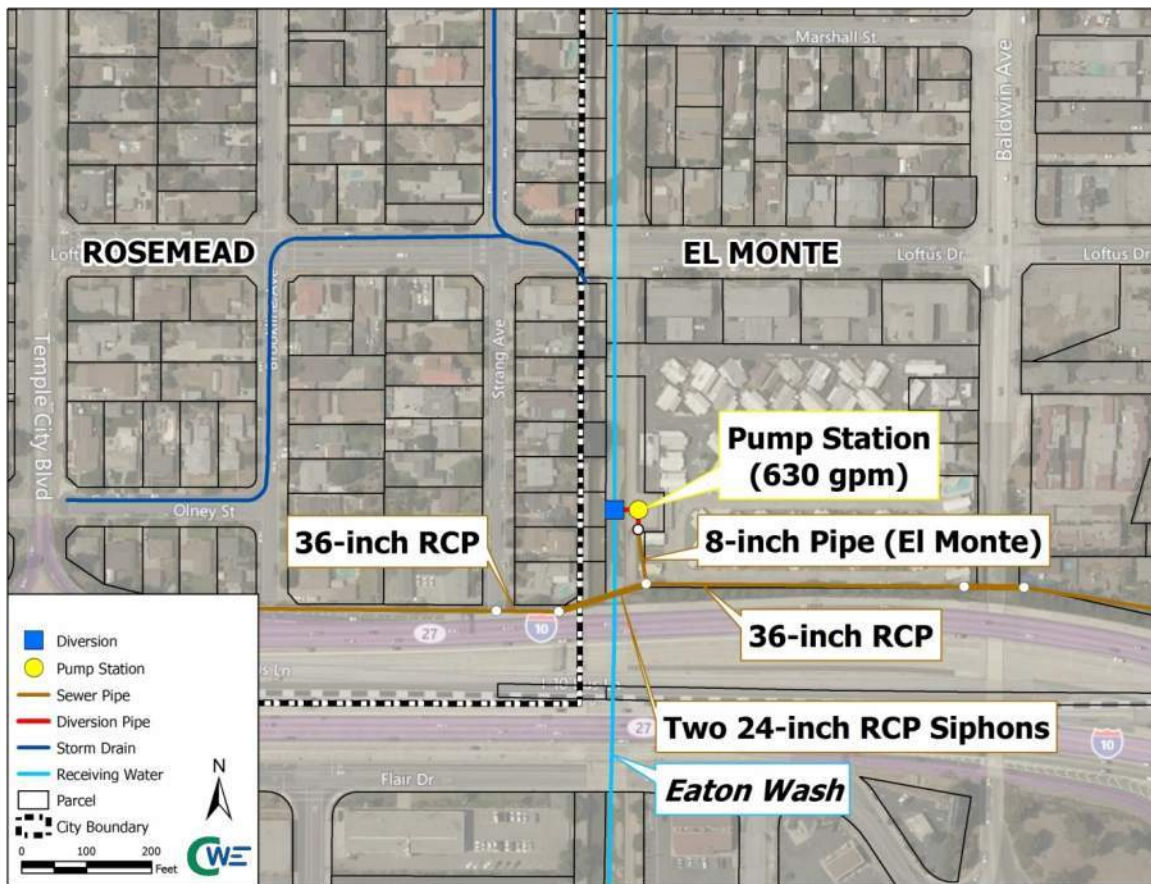

**Figure 4-4 Eaton Wash Alternative E1: No Storage**

#### 4.2.2 Eaton Wash Alternative E2: In-Line Storage

Eaton Wash Alternative E2 includes a low flow diversion with an in-line storage component and optimized daytime and nighttime discharge rates. A rubber dam (Diversion Alternative 3) will be used to divert flows and also provide storage within the channel, up to a volume of 1.87 acre-feet, as discussed in **Section 5** and **Section 6**. Diverted flows will be conveyed to a pump well and discharged into the manhole described under Alternative E1. Flows will be stored behind the rubber dam within the channel during the day and be discharged at an optimized peak rate of 965 gpm at night. **Figure 4-5** illustrates the preliminary site layout for Alternative E2. The in-line storage extent is shown with a cross hatch pattern, while this is not representative of a new structure. Preliminary design plans are included in **Appendix D**.



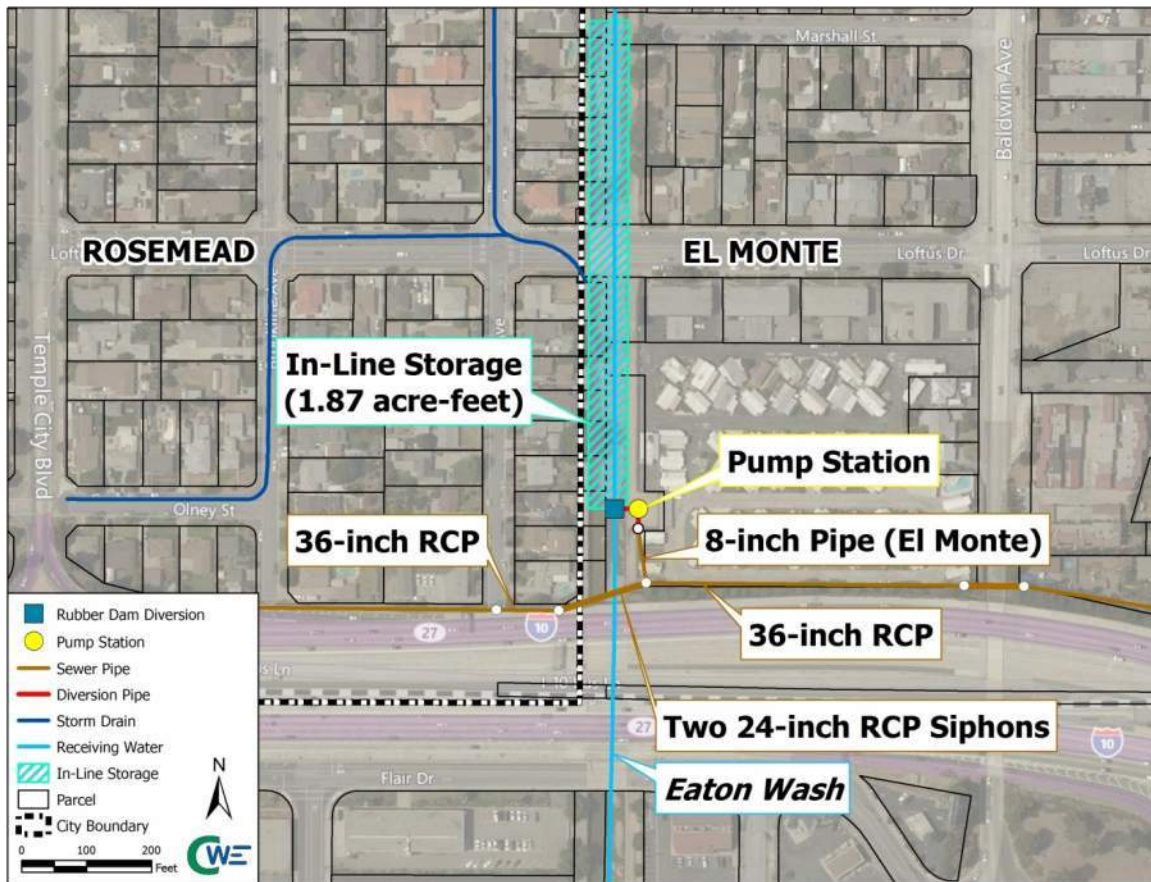

Figure 4-5 Eaton Wash Alternative E2: In-Line Storage

### 4.3 Rubio Wash

The following three alternatives for diverting dry-weather flows to the sanitary sewer were evaluated for Rubio Wash, each of which are described further in the following subsections:

1. Low flow diversion with no storage and the LRS-defined discharge rate
2. Low flow diversion with in-line storage with optimized discharge rates
3. Low flow diversion with off-line storage with optimized discharge rates

#### 4.3.1 Rubio Wash Alternative R1: No Storage

Rubio Wash Alternative R1 includes a low flow diversion with no storage component and a discharge rate equal to the LRS-defined discharge rate (800 gpm), as indicated in **Table 4-1**. Low flows will be diverted from Rubio Wash via Diversion Alternative 1 or Diversion Alternative 2, as discussed in **Section 5**. Flows will be conveyed to a pump well and discharged into the 57-inch VCP sewer line that crosses the privately owned parcel adjacent to Rubio Wash in a manhole just upstream of the siphon that crosses Rio Hondo. The sewer line is owned and maintained by LACSD. LACSD also confirmed that the sewer connection could be located on the 42-inch RCP north of the diversion if a new manhole is constructed. This option will be further evaluated if this design approach is ultimately selected for

implementation. The sewer alignments shown in the figures below are based on files provided by LACSD. Slight deviations were found through a site-specific survey, which is reflected in the preliminary design plans. **Figure 4-6** illustrates the preliminary site layout for Alternative R1. Preliminary design plans are included in **Appendix D**.

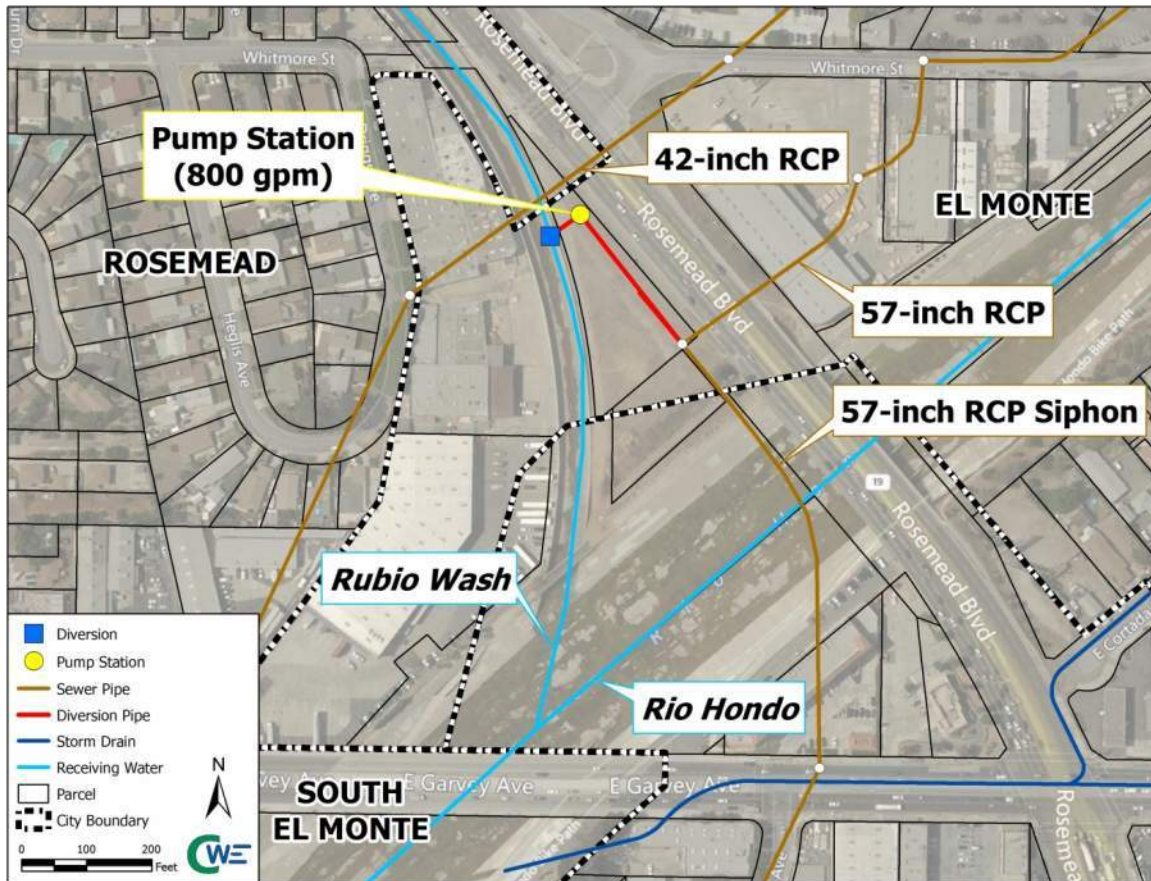

**Figure 4-6 Rubio Wash Alternative R1: No Storage**

#### 4.3.2 Rubio Wash Alternative R2: In-Line Storage

Rubio Wash Alternative 2 includes a low flow diversion with an in-line storage component and optimized daytime and nighttime discharge rates. A rubber dam (Diversion Alternative 3) will be used to divert flows and also provide storage within the channel, up to a volume of 0.92 acre-feet, as discussed in **Section 5** and **Section 6**. Diverted flows will be conveyed to a pump well and discharged into the sewer consistent with Alternative R1. Flows will discharge at an optimized rate of 225 gpm during the day and 1,436 gpm at night, per the analysis in **Section 6**. **Figure 4-7** illustrates the preliminary site layout for Alternative R2. The in-line storage extent is shown with a cross hatch pattern, while this is not representative of a new structure. Preliminary design plans are included in **Appendix D**.



Figure 4-7 Rubio Wash Alternative R2: In-Line Storage

### 4.3.3 Rubio Wash Alternative R3: Off-Line Storage

Rubio Wash Alternative R3 includes a low flow diversion with an off-line storage component and optimized daytime and nighttime discharge rates. Low flows will be diverted from Rubio Wash via Diversion Alternative 1 or Diversion Alternative 2, as discussed in **Section 5**, and stored in a subsurface storage structure that is proposed within the private parcel adjacent to the left bank of the channel. The storage structure will have a design capture volume of 0.92 acre-feet, consistent with Alternative R2. Stored flows will be conveyed to a pump well and discharged into the sewer using the same layout as the previously discussed alternatives. The optimized daytime and nighttime discharge rates will be the same as Alternative R2, 225 and 1,436 gpm, respectively. **Figure 4-8** illustrates the preliminary site layout for Alternative R3. Preliminary design plans are included in **Appendix D**.

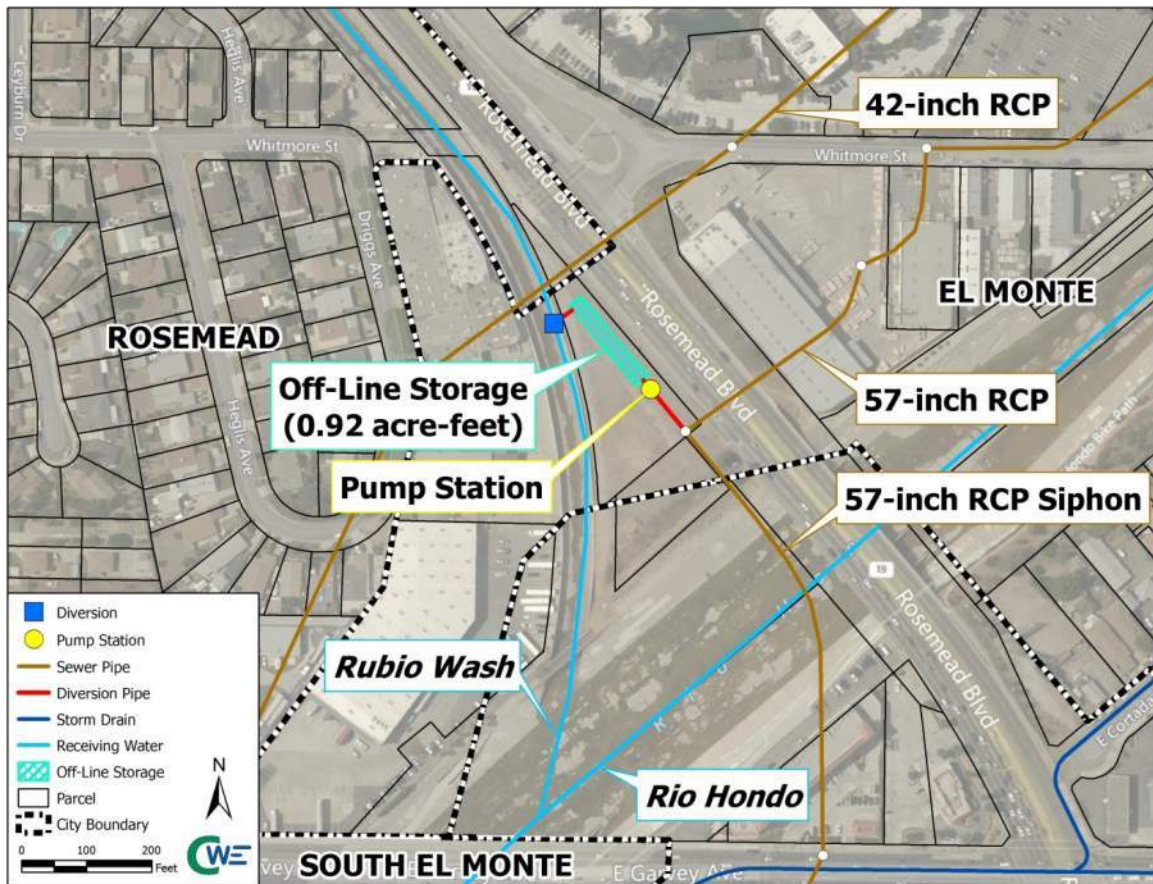

Figure 4-8 Rubio Wash Alternative R3: Off-Line Storage

## 5. Sewer Diversion Project Components

The low flow diversions at each of the three sites are unique, but would generally contain the same components: a diversion, pump, storage system, and sewer connection. The following sections describe each of the components and presents alternatives considered for each component, as applicable. Pros and cons of each component alternative evaluated are included to clearly identify the benefits and drawbacks associated with the different options.

### 5.1 Diversion System

A diversion system is necessary at each site to convey flows from the existing channel to the proposed pump system. Three alternatives are considered for the diversion system. These alternatives are described further below. Preliminary drawings are provided in **Appendix E**.

#### 5.1.1 Diversion Alternative 1: Grated Trench

Diversion Alternative 1 incorporates a steel-grated trench that lies along the width of each wash, perpendicular to flow, as shown in **Figure 5-1**. This alternative can be used with Alternatives A1, A3, E1, R1, and R3 described in **Section 4**. Flows within each wash will drop into the trench through the grate and travel towards the bank of the channel where they will be conveyed to the proposed pump well. The steel grate cover will be sloped slightly upgrade (perpendicular to flow) to easily capture flows and promote self-cleaning during large storm events, as large flows will push debris off the grate and downstream. The steel grate shall be traffic-rated with at least an H-20 loading rate to sustain loads from maintenance vehicles that travel in the channel.

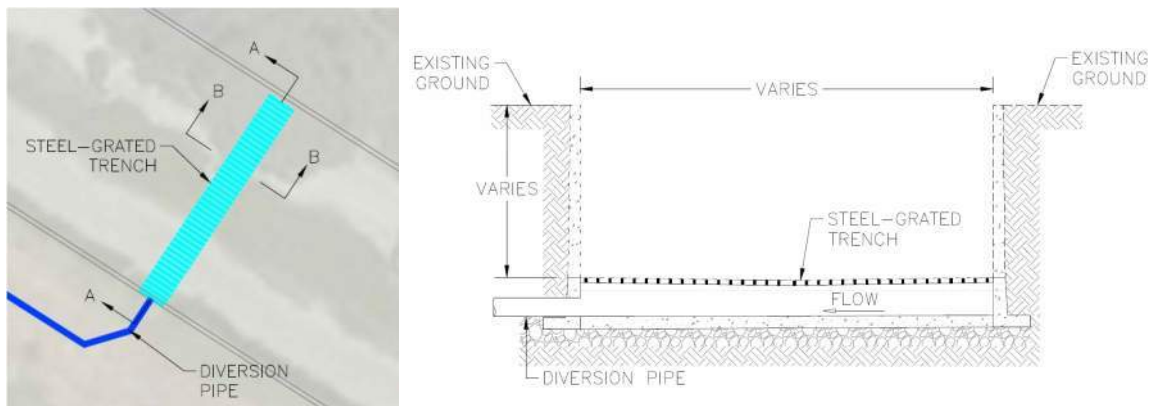

**Figure 5-1 Diversion Alternative 1 - Grated Trench**

Construction activities associated with Diversion Alternative 1 will include excavation, backfilling, compaction, minor grading, concrete work, grate installation, and diversion pipe installation. To install this diversion structure, portions of the concrete channel bottom and footings will be removed and reconstructed. The new concrete trench will be constructed following pipe installation and doweled into the existing channel bottom.

The grated trench will require periodic maintenance. The trench can fill with sediment and get clogged with debris. The steel grate will need to be removable so that sediment and debris in the trench can be

removed. The sloped design of the grate will help promote self-cleaning, but over time, debris and sediment may accumulate. It is important that the system is inspected regularly to determine when maintenance is necessary.

The trench will be sized to divert only dry-weather flows. During wet-weather events, stormwater will fill the pump well and the pumps will not turn on. Flows will back up into the channel, eventually flowing over the grate and continuing downstream in each wash. The grated trench will not cause a significant increase in the Water Surface Elevation (WSE) during the design event (high storm flows). **Table 5-1** summarizes the pros and cons associated with Diversion Alternative 1.

**Table 5-1 Pros and Cons of Diversion Alternative 1**

Pros	Cons
<ul style="list-style-type: none"> <li>➤ Self-cleans during large storm events</li> <li>➤ Effectively captures flows</li> <li>➤ Has been implemented and performed well within Los Angeles County</li> <li>➤ Preferred by LACFCD</li> </ul>	<ul style="list-style-type: none"> <li>➤ Higher initial cost as compared to Alternative 2</li> <li>➤ More intrusive construction within channel bottom and footing</li> <li>➤ Sediment build up in the grated trench will require periodic maintenance</li> </ul>

### 5.1.2 Diversion Alternative 2: Concrete Weir

Diversion Alternative 2 incorporates two concrete weirs that run diagonally along the width of each wash, as shown in **Figure 5-2**. This alternative can be used with Alternatives A1, A3, E1, R1, and R3 described in **Section 4**. The weirs will direct dry-weather runoff towards a diversion box with a steel-grated inlet. Two weirs are required because the channels currently slope towards the middle to concentrate low flows. The steel grate will be traffic rated with at least an H-20 loading rate to sustain loads from maintenance vehicles that travel in the channel. The concrete weirs will also be traffic rated and will increase in height gradually so that vehicles can easily drive over them. The height of the weirs will be dictated based on the channel geometry. Captured flows will travel through a diversion pipe to the proposed pump well. The grated inlet will prevent large debris from entering the system.

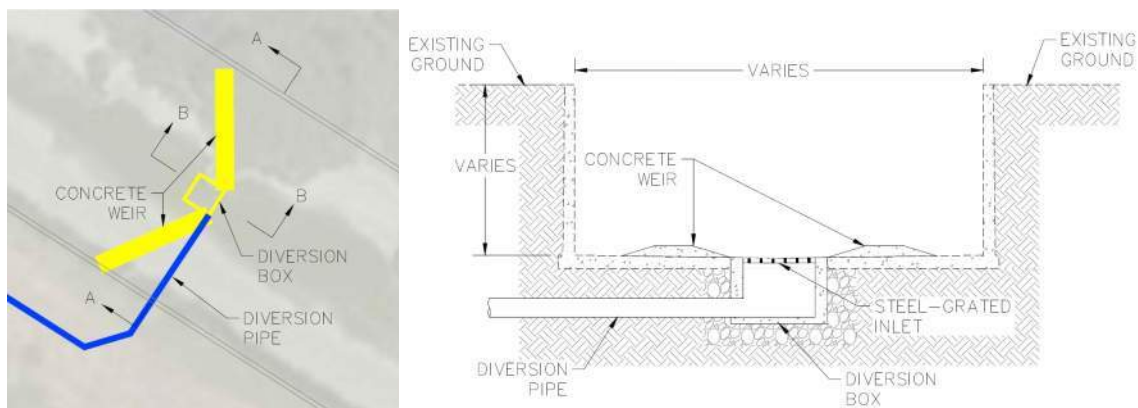

**Figure 5-2 Diversion Alternative 2 - Concrete Weirs**

Construction activities associated with Diversion Alternative 2 are less intrusive than the activities required for construction of Diversion Alternative 1. Concrete work will be required to form the weir and diversion box, which will be connected to the existing channel structure using dowels. Similar to Diversion Alternative 1, a portion of one of the channel bottom will be demolished for the diversion pipe

and box installation. Trenchless pipe installation shall be used to install the diversion pipe by using the channel bottom excavation as a receiving pit and pump well excavation as the launching pit. The diversion pipe shall be installed a minimum of 2.5 feet below the channel wall footing. This approach allows the structural integrity of the channel to be maintained and minimizes structural impacts to the channel.

Periodic maintenance will be necessary to maintain the effectiveness of the diversion structure. The steel grate and diversion box will require inspection to verify whether debris and sediment has clogged the system. Sediment may accumulate behind the weir and in the diversion box. Debris and sediment shall be removed as necessary based on regular inspection findings. It is anticipated that heavy storm events will flush some sediment and debris downstream. The structural stability of the weir will require inspection and restoration as necessary, although this is not anticipated often.

The diversion system will be sized to divert only dry-weather flows. During wet-weather events, stormwater will fill the pump well and the pumps will not turn on. Flows will back up into the channel, eventually flowing over the weir and continuing downstream in each wash. The weir will not cause a significant increase in the WSE during the design event (high storm flows). **Table 5-2** summarizes the pros and cons associated with Diversion Alternative 2.

**Table 5-2 Pros and Cons of Diversion Alternative 2**

Pros	Cons
<ul style="list-style-type: none"> <li>➤ Effectively captures flows</li> <li>➤ Least expensive (cheaper materials and construction methods)</li> <li>➤ Has been implemented and performed well within Los Angeles County</li> </ul>	<ul style="list-style-type: none"> <li>➤ Grated inlet may clog with trash and debris</li> <li>➤ Concrete weirs may need to be re-built periodically to maintain performance if damage is caused</li> </ul>

### 5.1.3 Diversion Alternative 3: Rubber Dam

Diversion Alternative 3 is similar in design to Diversion Alternative 2. However, instead of concrete weirs to direct low flows, Diversion Alternative 3 proposes a rubber dam. This alternative can be used with any alternative, but it is necessary if in-line storage alternatives are to be implemented (Alternatives A2, E2, and R2 described in **Section 4**). Diversion Alternative 3 incorporates a rubber dam that runs along the width of each wash, as shown in **Figure 5-3**. The rubber dam will impound dry-weather runoff within the channel, providing storage and allowing flows to pass through the steel grated inlet and into the diversion box when the pump system is operating. As part of the preliminary design, it is anticipated that the height of the rubber dam, once inflated will be up to half the channel depth, excluding freeboard, if the a sewer diversion is ultimately selected (approach detailed in **Section 5**). The rubber dam is anticipated to be inflated 5 feet at Alhambra Wash, 3.625 feet at Eaton Wash, and 3.75 feet at Rubio Wash. The steel grate will be traffic rated with at least an H-20 loading rate to sustain loads from maintenance vehicles that travel in the channel. The rubber dam can be deflated to allow vehicles to easily drive over it. Captured flows will travel through a diversion pipe to the proposed pump well. Portions of the channel will need to be replaced to install the rubber dam. The rubber dam shall be strategically placed to minimize channel replacement required. The diversion pipe shall be installed beneath the panel being removed. Alternatively, the diversion pipe could be installed using trenchless installation methods, as described with the previous alternatives.

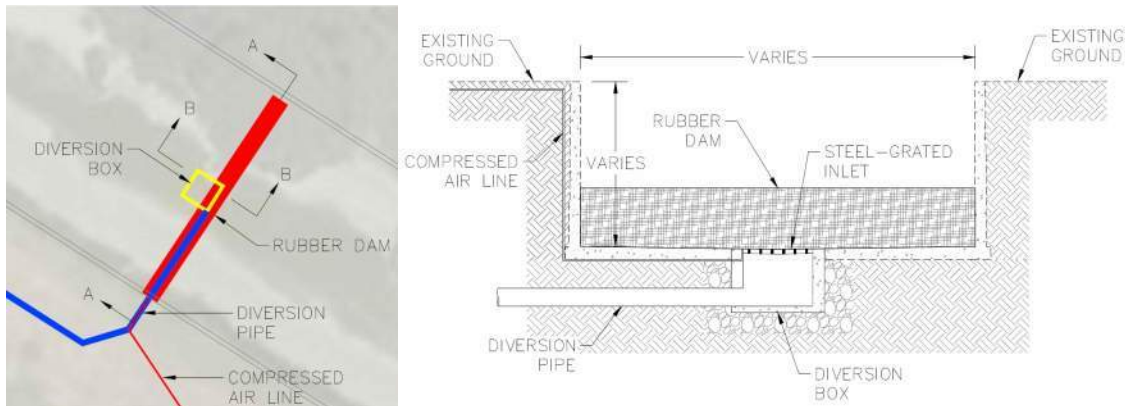

**Figure 5-3 Diversion Alternative 3 - Rubber Dam**

Similar to Diversion Alternative 2, construction activities associated with this concept are less intrusive than the activities required for construction of Diversion Alternative 1. In addition to the activities described under Alternative 2, mechanical equipment must be installed, including a compressor and electrical equipment. The rubber dam must also be installed, which includes affixing the rubber dam to the bottom of the channel. The rubber dam will require the installation of a control structure to which the compressed air line will connect.

Periodic maintenance will be necessary to maintain the effectiveness of the diversion structure. The steel grate and diversion box will require inspection to verify whether they are clogging. Sediment may accumulate behind the rubber dam and in the diversion box. Debris and sediment will require removal as necessary based on findings during regular inspections. It is anticipated that heavy storm events will flush some of these sediments downstream. The rubber dam will require inspection and restoration as necessary.

During wet-weather events, the rubber dam will be deflated and will flatten to mimic the existing channel bottom. Flows will bypass the diversion system as described under Alternative 2. The rubber dam will not have a significant effect on the WSE during the design event (high storm flows), while there will be some changes at the invert. Modeling during the final design will quantify the impact on the WSE.

**Table 5-3** summarizes the pros and cons associated with Diversion Alternative 3.

**Table 5-3 Pros and Cons of Diversion Alternative 3**

Pros	Cons
<ul style="list-style-type: none"> <li>➤ Effectively captures flows</li> <li>➤ Proposed as a part of many Los Angeles River Revitalization projects and currently implemented in LACFCD channels</li> <li>➤ Provides in-line storage, which has a smaller impact as compared to off-line storage</li> </ul>	<ul style="list-style-type: none"> <li>➤ Grated inlet may clog with trash and debris</li> <li>➤ Rubber dam may need to be patched or replaced periodically to maintain performance</li> <li>➤ Will require additional technical components for inflation</li> <li>➤ Requires skilled operation and maintenance</li> <li>➤ Most expensive</li> </ul>



## 5.2 Pump

LACSD requires that any connection to a sewer line from a storm system to utilize a pump to prevent backflow of sewer flows into the storm drain/channel system. As such, a pump system is proposed for all three washes and will control the rate and time of day flows are discharged to the sewer. The pump will operate based on the flow rates and times approved by LACSD, which will vary for each site. The pump system will be designed to receive rain gage data throughout the tributary watershed. The pump will not operate if rain greater than 0.1 inches is measured within the site’s drainage area, consistent with LACSD requirement. The method by which this information is received will be determined during final design and must be approved by LACSD, as this is the first regional project of its kind in coordination with LACSD, while previously approved projects could satisfy this requirement with an onsite rain gage.

Each pump system contains several key components, the most important of which are summarized in **Table 5-4**.

**Table 5-4 Summary of Key Pump Components**

Component	Description
Pump well	<ul style="list-style-type: none"> <li>➤ Concrete that can withstand H-20 loading (likely precast)</li> <li>➤ Varying diameters, anticipated to be 10-12 feet</li> <li>➤ Varying depths, anticipated to extend approximately 7 feet beneath channel bottom</li> </ul>
Pump/motor	<ul style="list-style-type: none"> <li>➤ Submersible pump</li> <li>➤ Requires a Variable Frequency Drive (VFD) to allow for varying flow rate to be pumped, up to the peak rates discussed in <b>Section 6</b></li> <li>➤ Redundant pump proposed (two pump system with one operating at a time)</li> </ul>
Valves/meters	<ul style="list-style-type: none"> <li>➤ Various valves proposed to control pipe flow and prevent backflow</li> <li>➤ Check valve will be placed on discharge line, potentially on vertical segment within wet well to eliminate need for valve vault</li> <li>➤ Flow meter with separate vault required on force main to quantify flows discharged to sewer</li> </ul>
Supervisory Control and Data Acquisition (SCADA)	<ul style="list-style-type: none"> <li>➤ Required to communicate with LACSD</li> <li>➤ Will likely utilize/tie into LACFCD SCADA system</li> <li>➤ Will control, and communicate information regarding, operations</li> </ul>
Electrical service	<ul style="list-style-type: none"> <li>➤ Will requires separate service (likely from SCE)</li> <li>➤ May require local upgrades if capacity is not available (anticipated to require three phase, 480 volts)</li> <li>➤ Panel will be required onsite</li> </ul>

## 5.3 Storage

Storage can be utilized to optimize the volume of dry-weather runoff that could be treated by the Project and the flow rates discharged to the sewer during a specific time period. A storage system would allow a higher flow rate of runoff to be captured, stored, and pumped into the sanitary sewer at a later time and will also work as a flow equalizer by allowing the discharge rate to the sewer to be steadier. A pump system is required at each wash, therefore, the storage does not need to be lower than the channel invert elevation, as it would be for a gravity-controlled system. The two storage approaches considered for the Project, as introduced in **Section 4**, include in-line storage within the channel through the use of a rubber dam and off-line storage in the form of subsurface structures. As presented above, in-line

alternatives are under consideration for all three washes (Alternatives A2, E2, and R2), while off-line subsurface storage is under consideration for Alhambra and Rubio Washes (Alternatives A3 and R3). The subsurface storage approach would include rectangular reinforced concrete structures, typically precast, that would be placed beneath the surface to store captured flows. The structure would include manhole access, similar to a box culvert.

The in-line storage approach is the most cost effective, as it only requires construction of a rubber dam, which takes advantage of the existing channel structure to provide storage, as compared to an off-line system, which requires significant excavation and construction. The capacity of the storage system is dependent on actual dry-weather flows experienced within each wash and the discharge rate limits enforced by LACSD. The flow analysis, detailed in **Section 6**, considered historic flows at each location and identifies optimized daytime and nighttime discharge rates, along with storage sizing. The in-line storage approach requires more complex maintenance, as the rubber dam system includes compressors, controls, and equipment that are not standard for most Permittees, as compared to subsurface storage system that requires sediment removal with a vacuum truck, which is fairly standard. **Table 5-5** and **Table 5-6** summarize pros and cons of the in-line and off-line storage approaches, respectively, understanding that LACSD discharge requirements and Permittee maintenance capabilities may ultimately decide which approach is implemented.

**Table 5-5 Pros and Cons of In-Line Storage**

Pros	Cons
<ul style="list-style-type: none"> <li>➤ Least expensive for providing storage</li> <li>➤ Less intrusive than off-line storage</li> <li>➤ Utilize existing structures, which minimizes construction impacts</li> <li>➤ Dual purpose (diversion and storage)</li> </ul>	<ul style="list-style-type: none"> <li>➤ Requires specialized maintenance</li> <li>➤ Compressor may be noisy</li> <li>➤ Requires control house/equipment</li> <li>➤ Storage capacity limited based on channel geometry</li> </ul>

**Table 5-6 Pros and Cons of Off-Line Subsurface Storage**

Pros	Cons
<ul style="list-style-type: none"> <li>➤ Reduces discharge flow rate</li> <li>➤ Provides steadier discharge to sewer</li> <li>➤ Potential to increase amount of flows captured</li> </ul>	<ul style="list-style-type: none"> <li>➤ More expensive compared to in-line storage</li> <li>➤ Greater construction impact</li> <li>➤ May require acquisitions</li> <li>➤ Additional maintenance</li> </ul>

## 5.4 Sewer Connection

Pumped flows will be conveyed through a force main to an existing sewer manhole in the vicinity of the diversion, as illustrated in the concepts presented in **Section 4**. Flows will be discharged into the manhole and continue to flow along the gravity-controlled sewer line. The invert of the proposed connection will be above the soffit of the existing sewer pipes to prevent backflow into the force main, even though flows would not be able to back up past the valves included downstream of the pump station. Energy dissipation is not anticipated, but will be evaluated as part of the final design. A flow meter will be placed upstream of the sewer connection to record the quantity of flows discharged into the sewer, as this will be used to determine the appropriate fee the Permittees must pay to LACSD for the conveyance and treatment of flows. Flows will not be discharged to the sewer if rain is recorded within the tributary drainage area or if a 20% Lower Explosive Limit (LEL) is detected in a gas meter that will be implemented within the diversion system as part of the Project. The flow meter, gas detector, and operational requirements are dictated by LACSD and are further summarized in **Section 9.8**.

## 6. Flow Analysis

A detailed dry-weather flow analysis was requested by LACSD and the Main San Gabriel Basin Watermaster for Alhambra, Eaton, and Rubio Washes as part of the permitting and approval process with LACSD. The meeting with the watermaster is required as part of Senate Bill (SB) 485, which states:

*Prior to initiating a stormwater or dry-weather runoff program or project within the boundaries of an adjudicated groundwater basin, a district shall consult with the relevant watermaster for a preliminary determination as to whether the project is inconsistent with the adjudication. If the watermaster deems the project to be inconsistent with the adjudication, the watermaster shall recommend, in writing, the measures that are necessary in order to conform the project to the adjudication.*

The detailed flow analysis evaluates historical flow data within each channel to determine what the discharge to the sewer would be like. This was requested by LACSD because the original capacity request was based on the sewer discharge rates approved by the LARWQCB as part of the Rio Hondo LRS and LACSD wanted to better understand impacts to their sewer system. Dry-weather flow is extremely variable and LACSD wanted to better understand how often flows would be discharged at the peak and at what times of the day. The flow analysis was also used to assess storage options and different discharge rates that would ultimately achieve the Rio Hondo LRS goals. The upstream portions of the tributary watersheds were evaluated to determine if natural flows are discharging to the washes and would be captured by the Project. The evaluation is included in **Appendix F** and no natural discharges were observed during the evaluation. This section summarizes the approach and findings of the detailed flow analysis performed.

### 6.1 Data Analysis Approach

Historical flow data was obtained for gaging stations on each wash. Historical rain data from the El Monte Fire Station rain gage was used to correlate flow data to storm events to differentiate them from dry-weather discharges. Days with measurable rain (greater than 0.1 inches) and days within 48 hours following a day with measurable rain were removed from the analysis. This procedure was based on a conservative analysis of the LAR Bacteria TMDL guidance, which exempts storm days and the following 48 hours from dry-weather bacterial load compliance. Flow data provided in hourly instantaneous readings from October 1, 2000 to September 30, 2015 served as the basis for the analyses performed. This date range corresponds to the date range used in the Rio Hondo LRS, which established the approved discharge flow rates. Additional flow data from October 1, 2015 to September 30, 2018 has been included in the seasonal data summary for comparison purposes.

The dry-weather flow rates based on the gaging data used in this analysis are referred to as "Discharge" flow rates, while the flow rates used in the Rio Hondo LRS are referred to as "LRS" flow rates. The Discharge flow rates (excluding the days removed due to rain) were capped at a rate equal to two times the LRS flow rates for the volume calculations, as it is unlikely flow rates greater than that are true dry-weather discharges. Possible sources for recorded measurements of high flows during dry-weather are errors in the flow measurements, flows associated with permitted discharges, or flows resulting from rain further upstream in the watershed, among other reasons. **Table 6-1** summarizes the LRS and capped Discharge flow rates by site.

**Table 6-1 LRS and Discharge Flow Rates**

Project Site	LRS Flow Rate		Capped Discharge Flow Rate	
	gpm	cfs	gpm	cfs
Alhambra Wash	1,000	2.23	2,000	4.46
Eaton Wash	630	1.40	1,260	2.80
Rubio Wash	800	1.78	1,600	3.56

A long-term “Discharge” hydrograph of dry-weather flow using the wet-weather exemptions and the high-flow caps described in the previous paragraphs were created, which were then compared to the LRS flow rate on a yearly basis to evaluate the amount of time that the low flow “Discharge” hydrograph exceeded the LRS flow rate, and to perform analyses of storage and pump size that would most efficiently convey dry-weather runoff to the sanitary sewer.

Discharge flow rates were compared to the LRS flow rates to better understand historical flow patterns. Seasonal and yearly average flow rates by day (8 am to 10 pm) and night (10 pm to 8 am) were quantified. The defined day and night hours are based on LACSD guidance, as different costs/rates apply to day versus night discharges. The model was used to identify the percentage of Discharge flow that was not captured by the Project at each site. Incorporating storage was assessed to identify if the LRS flow rates could be reduced, such that the same percentage of flows would be captured. It is important that the final design captures the same or more dry-weather flow as compared to the LRS flow rates, as these rates were approved by the LARWQCB and represent compliance with the dry-weather bacteria TMDL.

## 6.2 Comparison of Discharge and LRS Flow Rates

Historic flow rates were analyzed to determine how often dry-weather flow rates equaled the LRS flow rate, as shown in **Figure 6-1**. The measured flow rate was less than 50% of the LRS flow rate more than 90% of the time from 2015 to 2018 in Alhambra Wash. The opposite pattern is observed in Eaton Wash, with the measured flow rate increasing since 2015. The measured flow rate in Rubio Wash was less than 50% of the LRS flow rate more than 80% of the time from 2009 to 2018. The analysis shows that the LRS flow rate is greater than the observed flow rate most of the time, which aligns with the goal identified in the LRS to capture dry-weather flows.

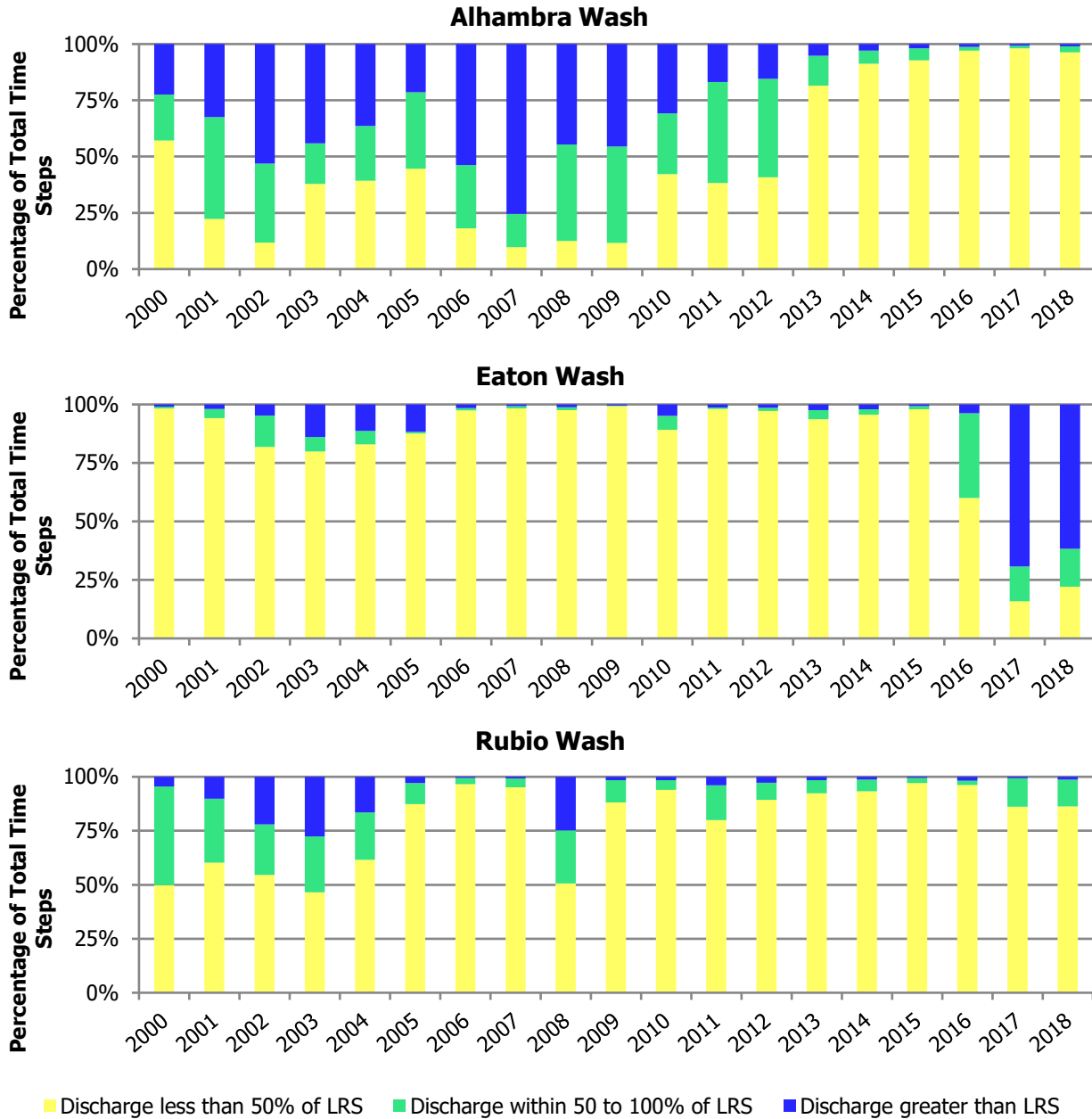

**Figure 6-1 Comparing Discharge and LRS Flow Rates**

### 6.3 Average Dry-Weather Discharge Flow Rates

The average Discharge flow rates for each wash were calculated by season on an annual basis, and by day versus night. Prior to 2015, the average Discharge flow rate for Alhambra Wash typically exceeded Eaton and Rubio Washes; however, since 2015, the Alhambra Wash flow rate has decreased and the Eaton Wash flow rate has increased. The average seasonal Discharge flow rates showed greater variation prior to 2008 for all three washes, with the average flow rates lower and with less variation since 2008. The average daytime flow rates were typically greater than the nighttime flow rates. Figures and additional information about average Discharge flow rates can be found in **Appendix G**.



## 6.4 Analysis 1: LRS Discharge with No Storage

After analyzing the Discharge flow rates for the three washes, the data was processed to determine the volume of water that would be captured by a dry-weather diversion with a capacity equal to the LRS flow rates. The volume represents how the diversions would have performed if they were constructed and in operation starting October 1, 2000 through September 30, 2015, which is consistent with the timeframe analyzed in the Rio Hondo LRS. **Table 6-2** summarizes the average annual captured volume that would have been diverted to the sewer during that timeframe based on the conditions described, the percentage of the total dry-weather runoff that would have been diverted, the percentage of the dry-weather runoff that would have bypassed the diversion, the maximum sewer discharge rate (equal to the LRS flow rate), and the average sewer discharge rate.

**Table 6-2 Analysis 1 Volume Summary**

Project Site	Average Annual Captured Volume	Diverted to Sewer	Bypass Volume	Maximum Sewer Discharge Flow Rate	Average Sewer Discharge Flow Rate
	acre-feet	%	%	gpm	gpm
Alhambra Wash	996	76.0%	24.0%	1,000	619
Eaton Wash	246	90.2%	9.8%	630	153
Rubio Wash	417	86.4%	13.6%	800	260

## 6.5 Analysis 2: Storage with Optimized Discharge Rates

Installing an inflatable rubber dam or subsurface structures could provide 2.05 acre-feet (ac-ft) of storage for Alhambra Wash, 1.87 ac-ft for Eaton Wash (in-line only), and 0.92 ac-ft for Rubio Wash. Additional information on the storage alternatives and layouts are included in **Section 4**. Incorporating storage and optimizing discharge flow rates can allow the same (or more) annual volume to be captured as without storage, but it allows the discharge into the sewer to proceed during nighttime hours (10 pm to 8 am), when the LACSD charges lower rates. In Alhambra Wash and Rubio Wash, in-line storage does not provide enough volume, so daytime discharges are still required, as shown in **Table 6-3**, while they are still significantly less than the daytime discharges. For Eaton Wash, no daytime discharge was needed to meet the volume requirement. The discharge rates require approval from LACSD, understanding that more capacity is available during nighttime hours. LACSD encouraged the use of some type of storage, as it will regulate discharge rates so that they are steadier as opposed to being highly variable. Additional off-line storage could be evaluated for Alhambra and Rubio Washes if the rates shown below are not approved by LACSD.

**Table 6-3 Analysis 2 Volume Summary with Storage**

Project Site	Storage Volume	Average Annual Captured Volume	Maximum Daytime Discharge Flow Rate	Maximum Nighttime Discharge Flow Rate	Average Sewer Discharge Flow Rate
	acre-feet	acre-feet	gpm	gpm	gpm
Alhambra Wash	2.05	996	767	1,200	619 (537 Day; 730 Night)
Eaton Wash	1.87	246	0	965	153 (366 Night)
Rubio Wash	0.92	417	225	1,436	260 (159 Day; 398 Night)

## 7. Operations and Maintenance

Operations and Maintenance (O&M) is critical in project success and will prolong the Project's lifespan. This section summarizes general O&M requirements anticipated based on the preliminary sewer diversion design alternatives described above in this report. Operational fees associated with discharging to the sewer, which represent a significant portion of the necessary O&M budget, are included in this section.

**Table 7-1** summarizes the anticipated preliminary inspection and maintenance requirements by component. The O&M indicated in the table is expected to cost approximately \$115,000 per year per site based on similar projects within Los Angeles County.

**Table 7-1 Summary of Anticipated O&M by Project Component**

Component	Inspection/Operation/Maintenance	Inspection Frequency
Diversion System (inlet and pipe)	<ul style="list-style-type: none"> <li>➤ Inspect for accumulated sediment and debris</li> <li>➤ Remove accumulated sediment and debris (litter and leaves) from the grate and inside structure(s)</li> <li>➤ Inspect conveyance pipe for clogging</li> <li>➤ Remove accumulated materials from the pipe system</li> </ul>	Twice a year (at a minimum)
Pump System	<ul style="list-style-type: none"> <li>➤ Inspect pump well for sediment and debris and remove as necessary</li> <li>➤ Check valves for operation and clogging</li> <li>➤ Clear material and replace valves as necessary</li> <li>➤ Inspect bearings and impeller for wear</li> <li>➤ Lubricate bearings as needed</li> <li>➤ Check pump for operation</li> <li>➤ Verify pump levels have been maintained</li> <li>➤ Consult manufacturer if pump has not been operated in more than 12 months or if more extensive maintenance is required</li> <li>➤ During operation, check pump for excessive noise, vibration, or other abnormal conditions</li> <li>➤ Refer to manufacturer recommendations</li> </ul>	Twice a year (at a minimum)
Off-Line Storage Structure (if utilized)	<ul style="list-style-type: none"> <li>➤ Inspect for clogging at inlet pipes</li> <li>➤ Clear debris and material at inlet if clogged</li> <li>➤ Inspect for sediment accumulation within storage area</li> <li>➤ Use a vacuum truck to remove accumulated sediment and debris as appropriate</li> </ul>	Twice a year (at a minimum)
Connection to Sewer	<ul style="list-style-type: none"> <li>➤ Inspect conveyance pipe for clogging</li> <li>➤ Remove accumulated materials from the pipe system</li> </ul>	Twice a year (at a minimum)



Component	Inspection/Operation/Maintenance	Inspection Frequency
Flow Meter	<ul style="list-style-type: none"> <li>➤ Inspect flow data to identify anomalies</li> <li>➤ Troubleshoot with manufacturer if data anomalies observed</li> <li>➤ Mostly maintenance free, but should be calibrated annually</li> </ul>	Once a year
Gas Detector	<ul style="list-style-type: none"> <li>➤ Detectors should be inspected and serviced as needed by an experienced technician</li> </ul>	Twice a year

## 7.1 Sanitary Sewer Discharge Fees

Each of the alternatives presented in **Section 4** propose a connection to an existing sanitary sewer line. Discharging runoff into these lines will require the imposition of an annual service fee. Fees are determined based on four primary variables: total annual discharge volume, daytime peak rate of discharge, Chemical Oxygen Demand (COD), and Total Suspended Solids (TSS). Total annual discharge volume and daytime peak rate of discharge varied for each alternative. Concentrations of COD and TSS were assumed to be of 21 mg/L and 26.4 mg/L, respectively, for each alternative. Initial pollutant estimates were based on local dry-weather monitoring results. Data from a monitoring site on Arcadia Wash just upstream of the Rio Hondo was referenced, along with a monitoring site on Rio Hondo downstream of the Project area. SGVCOG will be required to implement additional dry-weather monitoring prior to receiving approval from LACSD, as further mentioned in **Section 9.8**. **Table 7-2** summarizes calculated fees. Note that these annual fees are in addition to any potential costs associated with O&M as discussed above.

**Table 7-2 Sanitary Sewer Estimated Discharge Fees**

Project Site	Analysis 1: No Storage	Analysis 2: Storage
Alhambra Wash	\$397,096	\$356,149
Eaton Wash	\$198,750	\$82,529
Rubio Wash	\$257,104	\$140,044

## 7.2 Watermaster Fees

The Main San Gabriel Basin Watermaster wrote a letter (dated October 30, 2019) to SGVCOG regarding the SB 485 consultation, discussed in **Section 6**. A copy of the letter is included in **Appendix H**. At the beginning of the Project, it was assumed that diverted flows would be treated at the Whittier Narrows WRP and then used through the recycled water system or discharged for recharge at the Montebello Forebay (staying within the groundwater basin area/vicinity). It was later discovered that the Whittier Narrows WRP does not have sufficient capacity for the diverted flows, which would cause them to bypass downstream to the Joint Water Pollution Control Plant (JWPCP); therefore, leaving the basin. The Watermaster’s letter indicates that flows leaving the basin would be subject to Watermaster assessments, which at a minimum would include the prevailing Replacement Water assessment, which was \$834 per acre-foot at the time the letter was issued. Further coordination and negotiation would be required for the fees. **Table 7-3** summarizes the volume capture and fees based on **Section 6**.



**Table 7-3 Watermaster Potential Discharge Fees**

<b>Project Site</b>	<b>Average Annual Volume Capture (acre-feet)</b>	<b>Average Annual Watermaster Fee (at \$834/acre-foot)</b>
Alhambra Wash	996	\$830,664
Eaton Wash	246	\$205,164
Rubio Wash	417	\$347,778

## 8. Probable Costs

Preliminary opinions of probable cost for each proposed sewer diversion alternative (**Section 4**) are summarized in **Table 8-1** below. Complete cost opinions are provided in the following sections. The cost opinions do not include costs associated with land acquisition, which are discussed in **Section 9.9**, which may apply to Alhambra Wash Alternative A3 and Rubio Wash (all alternatives to some extent). The estimates do not include annual costs for O&M and other fees, as they are discussed in **Section 7**.

**Table 8-1 Summary of Opinions of Probable Cost**

Project Site	Alternative	Cost
Alhambra Wash	A1: No Storage	\$1,501,200
	A2: In-Line Storage	\$2,158,150
	A3: Off-Line Storage	\$5,327,100
Eaton Wash	E1: No Storage	\$1,067,120
	E2: In-Line Storage	\$1,789,400
Rubio Wash	R1: No Storage	\$1,117,750
	R2: In-Line Storage	\$1,917,050
	R3: Off-Line Storage	\$2,942,150

### 8.1 Alhambra Wash

Three preliminary cost opinions were generated for the Alhambra Wash site based on the LRS approach to divert to the sanitary sewer. Each is described further below. The cost opinions were developed using various sources of information as well as the engineer's best judgement. A contingency of 30 percent is included due to the preliminary nature of the opinion and will be decreased in design level opinions.

#### 8.1.1 Alhambra Wash Alternative A1: No Storage

**Table 8-2** presents a preliminary cost opinion for Alhambra Wash Alternative A1, which features no storage component. The estimate assumed Diversion Alternative 2 as the selected diversion structure, as it presented the lowest cost.

**Table 8-2 Opinion of Probable Cost for Alhambra Wash Alternative A1**

Item No.	Description	Unit	Quantity	Unit Price	Total
1	Mobilization (10%)	LS	1	\$105,000	\$105,000
2	Diversion Structure (Alternative 2)	LS	1	\$40,000	\$40,000
3	Diversion Line	LF	90	\$130	\$11,700
4	Pump	LS	1	\$463,000	\$463,000
5	Force Main	LF	2,610	\$100	\$261,000
6	Sanitary Sewer Connection	LS	1	\$4,000	\$4,000
7	Site Demolition	LS	1	\$60,000	\$60,000
8	SCADA and Electrical Appurtenances	LS	1	\$180,000	\$180,000
9	Meter and Vault	LS	1	\$25,000	\$25,000
10	Sampling Vault	LS	1	\$5,000	\$5,000
Total					\$1,154,700
30% Contingency					\$346,500
<b>Grand Total</b>					<b>\$1,501,200</b>

### 8.1.2 Alhambra Wash Alternative A2: In-Line Storage

**Table 8-3** presents a preliminary cost opinion for Alhambra Wash Alternative A2, which features an in-line storage component. The opinion assumed Diversion Alternative 3 as the selected diversion structure, as a rubber dam is necessary to store flows within the channel.

**Table 8-3 Opinion of Probable Cost for Alhambra Wash Alternative A2**

Item No.	Description	Unit	Quantity	Unit Price	Total
1	Mobilization (10%)	LS	1	\$151,000	\$151,000
2	Diversion Structure (Alternative 3)	LS	1	\$500,000	\$500,000
3	Diversion Line	LF	85	\$130	\$11,050
4	Pump	LS	1	\$463,000	\$463,000
5	Force Main	LF	2,610	\$100	\$261,000
6	Sanitary Sewer Connection	LS	1	\$4,000	\$4,000
7	Site Demolition	LS	1	\$60,000	\$60,000
8	SCADA and Electrical Appurtenances	LS	1	\$180,000	\$180,000
9	Meter and Vault	LS	1	\$25,000	\$25,000
10	Sampling Vault	LS	1	\$5,000	\$5,000
Total					\$1,660,050
30% Contingency					\$498,100
<b>Grand Total</b>					<b>\$2,158,150</b>

### 8.1.3 Alhambra Wash Alternative A3: Off-Line Storage

**Table 8-4** presents a preliminary cost opinion for Alhambra Wash Alternative A3, which features an off-line storage component. The opinion assumed Diversion Alternative 2 as the selected diversion structure, as it presented the lowest cost. The storage system was assumed to be a subsurface concrete structure

with a footprint of just under 9,000 square-feet and a depth of 10 feet. The estimate assumed a depth to top of structure of 18 feet.

**Table 8-4 Opinion of Probable Cost for Alhambra Wash Alternative A3**

Item No.	Description	Unit	Quantity	Unit Price	Total
1	Mobilization (10%)	LS	1	\$372,600	\$372,600
2	Diversion Structure (Alternative 2)	LS	1	\$40,000	\$40,000
3	Diversion Line	LF	70	\$130	\$9,100
4	Pump	LS	1	\$463,000	\$463,000
5	Force Main	LF	2,670	\$100	\$267,000
6	Sanitary Sewer Connection	LS	1	\$4,000	\$4,000
7	Storage	GAL	668,000	\$4	\$2,672,000
8	Site Demolition	LS	1	\$60,000	\$60,000
9	SCADA and Electrical Appurtenances	LS	1	\$180,000	\$180,000
10	Meter and Vault	LS	1	\$25,000	\$25,000
11	Sampling Vault	LS	1	\$5,000	\$5,000
Total					\$4,097,700
30% Contingency					\$1,229,400
<b>Grand Total</b>					<b>\$5,327,100</b>

## 8.2 Eaton Wash

Two preliminary opinions of probable cost were generated for the Eaton Wash site based on the LRS approach to divert to the sanitary sewer. Each is described further below. The cost opinions were developed using various sources of information as well as the engineer's best judgement. A contingency of 30 percent is included due to the preliminary nature of the opinion and will be decreased in design level opinions.

### 8.2.1 Eaton Wash Alternative E1: No Storage

**Table 8-5** presents a preliminary cost opinion for Eaton Wash Alternative E1 which features no storage component. The opinion assumed Diversion Alternative 2 as the selected diversion structure, as it presented the lowest cost.

**Table 8-5 Opinion of Probable Cost for Eaton Wash Alternative E1**

Item No.	Description	Unit	Quantity	Unit Price	Total
1	Mobilization (10%)	LS	1	\$74,620	\$74,620
2	Diversion Structure (Alternative 2)	LS	1	\$40,000	\$40,000
3	Diversion Line	LF	40	\$130	\$5,200
4	Pump	LS	1	\$418,000	\$418,000
5	Force Main	LF	90	\$100	\$9,000
6	Sanitary Sewer Connection	LS	1	\$4,000	\$4,000
7	Site Demolition	LS	1	\$60,000	\$60,000

Item No.	Description	Unit	Quantity	Unit Price	Total
8	SCADA and Electrical Appurtenances	LS	1	\$180,000	\$180,000
9	Meter and Vault	LS	1	\$25,000	\$25,000
10	Sampling Vault	LS	1	\$5,000	\$5,000
Total					\$820,820
30% Contingency					\$246,300
<b>Grand Total</b>					<b>\$1,067,120</b>

### 8.2.2 Eaton Wash Alternative E2: In-Line Storage

**Table 8-6** presents the cost opinion for Eaton Wash Alternative E2 which features an in-line storage component. The opinion assumed Diversion Alternative 3 as the selected diversion structure, as a rubber dam is necessary to store runoff within the channel.

**Table 8-6 Opinion of Probable Cost for Eaton Wash Alternative E2**

Item No.	Description	Unit	Quantity	Unit Price	Total
1	Mobilization (10%)	LS	1	\$125,200	\$125,200
2	Diversion Structure (Alternative 3)	LS	1	\$500,000	\$500,000
3	Diversion Line	LF	40	\$130	\$5,200
4	Pump	LS	1	\$463,000	\$463,000
5	Force Main	LF	90	\$100	\$9,000
6	Sanitary Sewer Connection	LS	1	\$4,000	\$4,000
7	Site Demolition	LS	1	\$60,000	\$60,000
8	SCADA and Electrical Appurtenances	LS	1	\$180,000	\$180,000
9	Meter and Vault	LS	1	\$25,000	\$25,000
10	Sampling Vault	LS	1	\$5,000	\$5,000
Total					\$1,376,400
30% Contingency					\$413,000
<b>Grand Total</b>					<b>\$1,789,400</b>

## 8.3 Rubio Wash

Three preliminary opinions of probable cost were generated for the Rubio Wash site based on the LRS approach to divert to the sanitary sewer. Each is described further below. The cost opinions were developed using various sources of information as well as the engineer's best judgement. A contingency of 30 percent is included due to the preliminary nature of the opinion and will be decreased in design level opinions.

### 8.3.1 Rubio Wash Alternative R1: No Storage

**Table 8-7** presents a preliminary cost opinion for Rubio Wash Alternative R1 which features no storage component. The opinion assumed Diversion Alternative 2 as the selected diversion structure, as it presented the lowest cost.

**Table 8-7 Opinion of Probable Cost for Rubio Wash Alternative R1**

Item No.	Description	Unit	Quantity	Unit Price	Total
1	Mobilization (10%)	LS	1	\$78,200	\$78,200
2	Diversion Structure (Alternative 2)	LS	1	\$40,000	\$40,000
3	Diversion Line	LF	35	\$130	\$4,550
4	Pump	LS	1	\$426,000	\$426,000
5	Force Main	LF	370	\$100	\$37,000
6	Sanitary Sewer Connection	LS	1	\$4,000	\$4,000
7	Site Demolition	LS	1	\$60,000	\$60,000
8	SCADA and Electrical Appurtenances	LS	1	\$180,000	\$180,000
9	Meter and Vault	LS	1	\$25,000	\$25,000
10	Sampling Vault	LS	1	\$5,000	\$5,000
Total					\$859,750
30% Contingency					\$258,000
<b>Grand Total</b>					<b>\$1,117,750</b>

### 8.3.2 Rubio Wash Alternative R2: In-Line Storage

**Table 8-8** presents a preliminary cost opinion for Rubio Wash Alternative R2 which features an in-line storage component. The opinion assumed Diversion Alternative 3 as the selected diversion structure, as a rubber dam is necessary to store runoff within the channel.

**Table 8-8 Opinion of Probable Cost for Rubio Wash Alternative R2**

Item No.	Description	Unit	Quantity	Unit Price	Total
1	Mobilization (10%)	LS	1	\$134,100	\$134,000
2	Diversion Structure (Alternative 3)	LS	1	\$500,000	\$500,000
3	Diversion Line	LF	35	\$130	\$4,550
4	Pump	LS	1	\$525,000	\$525,000
5	Force Main	LF	370	\$100	\$37,000
6	Sanitary Sewer Connection	LS	1	\$4,000	\$4,000
7	Site Demolition	LS	1	\$60,000	\$60,000
8	SCADA and Electrical Appurtenances	LS	1	\$180,000	\$180,000
9	Meter and Vault	LS	1	\$25,000	\$25,000
10	Sampling Vault	LS	1	\$5,000	\$5,000
Total					\$1,474,650
30% Contingency					\$442,400
<b>Grand Total</b>					<b>\$1,917,050</b>

### 8.3.3 Rubio Wash Alternative R3: Off-Line Storage

**Table 8-9** presents a preliminary cost opinion for Rubio Wash Alternative R3 which features an off-line storage component. The opinion assumed Diversion Alternative 2 as the selected diversion structure, as

it presented the lowest cost. The storage system was assumed to be a subsurface concrete structure with a footprint of 4,000 square-feet and a depth of 10 feet. The opinion assumed a depth to top of structure of 13 feet.

**Table 8-9 Opinion of Probable Cost for Rubio Wash Alternative R3**

Item No.	Description	Unit	Quantity	Unit Price	Total
1	Mobilization (10%)	LS	1	\$205,800	\$205,800
2	Diversion Structure (Alternative 2)	LS	1	\$40,000	\$40,000
3	Diversion Line	LF	55	\$130	\$7,150
4	Pump	LS	1	\$525,000	\$525,000
5	Force Main	LF	120	\$100	\$12,000
6	Sanitary Sewer Connection	LS	1	\$4,000	\$4,000
7	Storage	GAL	299,800	\$4	\$1,199,200
8	Site Demolition	LS	1	\$60,000	\$60,000
9	SCADA and Electrical Appurtenances	LS	1	\$180,000	\$180,000
10	Meter and Vault	LS	1	\$25,000	\$25,000
11	Sampling Vault	LS	1	\$5,000	\$5,000
Total					\$2,263,150
30% Contingency					\$679,000
<b>Grand Total</b>					<b>\$2,942,150</b>



## 9. Permits and Easement Evaluation

The Project will require coordination with various regulatory agencies throughout the design phase of the Project to obtain proper permits and approvals. Coordination with the United States Army Corps of Engineers (USACE) will be necessary, as the Project proposes connections to three USACE built facilities. Additionally, coordination for this Project may be required with the California Department of Fish and Wildlife (CDFW), LARWQCB, Division of State Architect (DSA), LACFCD, and LACSD. Local permits will also be required. Coordination with United States Fish and Wildlife Services (USFWS) as part of the Endangered Species Act was considered, but found to not be applicable, as the Project is on concrete-lined channels; therefore, the requirements are not discussed in this section. This section summarizes the anticipated requirements, approvals, and assessments necessary as part of the Project if the LRS approach (diversion to sewer) is implemented.

### 9.1 USACE Section 408

Section 14 of the Rivers and Harbors Act of 1899 and codified in 33 USC 408 (commonly referred to as "Section 408") authorizes the Secretary of the Army, on the recommendation of the Chief of Engineers of the USACE, to grant permission for the alteration or occupation of use of a USACE civil works project if the Secretary determines that the activity will not be injurious to the public interest and will not impair the usefulness of the project (USACE, 2018).

SGVCOG will need approval under Section 408, as the Project involves construction within and along Alhambra Wash, Eaton Wash, and Rubio Wash, each of which was built by USACE. These facilities were transferred for O&M to the LACFCD, as they were the local sponsor. USACE will grant permission under Section 408 if it is determined that the Project's authorized purpose and is not injurious to the public interest. LACFCD will coordinate with USACE for approval under Section 408. SGVCOG will submit the documents detailed in **Appendix I** with the LACFCD Connection Permit submittal detailed in **Section 9.7**, which will be reviewed and submitted to USACE upon review and approval by the LACFCD. The following list summarizes the major components of the Section 408 submittal.

1. General documentation
  - a. Application
  - b. Location map
  - c. As-builts
  - d. Photographs
2. Technical analysis and design documentation
  - a. Geotechnical investigation and analysis
  - b. Construction plans
  - c. Structural analysis
  - d. Hydrologic and hydraulic analysis
3. O&M documentation
4. Real estate documentation
5. Environmental compliance documentation

LACFCD will verify that the submittal package is complete and has no objections to the Project, before the package is sent to USACE for review. All comments and reviews will go through LACFCD and it generally takes one year to receive approval from USACE once the package has been approved by LACFCD and submitted. LACFCD has stated in the past that the hydraulic analysis method required is dependent on the flow conditions within each channel. Open channels with supercritical flow regimes require two-dimensional modeling, while one-dimensional modeling is sufficient for other flow regimes. Preliminary calculations suggest that Alhambra, Eaton, and Rubio Washes, in the Project vicinity, experience supercritical flow regimes and would likely then require two-dimensional modeling.

## 9.2 Clean Water Act Section 404

Section 404 of the Clean Water Act (CWA) establishes a program that requires a permit to be obtained prior to construction to regulate the discharge of dredged or fill material into the waters of the United States. The basic premise of the program is that no discharge of dredged or fill material may be permitted if a practicable alternative exists that is less damaging to the aquatic environment or the nation's waters would be significantly degraded. When applying for a permit, it must be clear that steps have been taken that will minimize potential impacts and that compensation will be provided for all remaining unavoidable impacts (USEPA, 2013).

Individual permits are reviewed by USACE and applications are evaluated under public interest review as well as Section 404 guidelines. For most discharges that will have only minimal adverse effects, a general permit may be suitable. General permits are issued on a nationwide, regional, or state basis for particular categories of activities (USEPA, 2013). The Project qualifies for authorization under Nationwide Permit (NWP) 7 (Outfall Structures and Associated Intake Structures), 18 (Minor Discharges), 33 (Temporary Construction, Access, and Dewatering), and 43 (Stormwater Management Facilities).

NWP 7 associates with the activities related to the construction or modification of outfall structures and associated intake structures, where the effluent from the outfall is authorized, conditionally authorized, or specifically exempted by, or otherwise in compliance with regulations issued under the NPDES program. The Project will divert flows out of each of the washes and therefore construction of an intake structure authorization may be needed. NWP 18 associates with minor discharges that do not exceed 25 cubic yards. It is anticipated that the Project will place concrete to reconstruct the channel diversion and NWP 18 may therefore be necessary. NWP 33 may be necessary for the temporary construction and access of the appurtenances within the washes including the diversion and potentially a rubber dam. NWP 43 is authorized for use in projects that are designed to reduce the inputs of sediments, nutrients, and other pollutants into waters to meet reduction targets established under TMDLs set under the Clean Water Act.

A Pre-Construction Notification Form (PCN) must be submitted to the USACE Los Angeles District Engineer as early as possible. Upon receipt, the District Engineer has 30 days to notify the applicant if the PCN is incomplete and request additional information. If the submittal is incomplete, the missing information will be necessary to complete the submittal package and resubmitted. Once USACE has received a complete submittal package, the applicant will be notified in writing that the activity may proceed under the NWP with any special conditions. If a notification has not been received within 45 days, the applicant can proceed with work, unless there are other conditions that require USACE notifications, such as if habitat will be impacted, or the receipt of a Section 401 certification.

**Appendix J** includes documents relevant to the USACE CWA Section 404 permitting process.

### 9.3 Fish and Wildlife Code 1600

Fish and Wildlife Code 1602 requires any entity to notify the CDFW before beginning any activity that will do one or more of the following:

1. Substantially obstruct or divert the natural flow of any river, stream, or lake.
2. Substantially change or use any material from the bed, channel, or bank of any river, stream, or lake.
3. Deposit or dispose of debris, waste, or other material containing crumbled, flaked, or ground pavement where it may pass into any river, stream, or lake.

The Notification of Lake or Streambed Alteration form must be completed and submitted along with the applicable fee to the South Coast Region (Region 5) to notify CDFW regarding the Project. **Appendix K** includes documents relevant to the Department Code 1600 approval process. The CDFW will review the application to determine if it is complete. Ample detail must be provided in the application to ensure it is deemed complete. Applicable special status studies, biological assessments, and hydrological studies must be included in the submittal package. Based on a preliminary review, endangered and threatened species are not expected to exist in the Project vicinity. If endangered or threatened species are found to exist, special status studies and biological assessments will be required for these species plus any other endangered/threatened species known in the area. Once the notification is determined to be complete, the application processing will begin.

Once the notification package is submitted to the CDFW, they have 30 days to determine completeness. If the package is incomplete additional information will be necessary to revise and resubmit the notification package. If the package is complete, it will be determined whether a Lake or Streambed Alteration Agreement is required for the proposed activity. If an agreement is required, the CDFW will conduct an on-site inspection if necessary and submit a draft agreement to the applicant that includes measures to protect fish and wildlife resources while conducting the project. If a regular agreement is sought, the CDFW will submit the draft agreement within 60 days. After the draft agreement is received, the applicant has 30 days to notify the CDFW whether the measures in the draft agreement are acceptable and a signed agreement must be resubmitted. If parts of the agreement are not acceptable to the applicant, they must meet with the CDFW within 14 calendar days to resolve the disagreement. If the applicant does not respond within 90 days, the agreement will be withdrawn by the CDFW (CDFW, 2008).

### 9.4 Clean Water Act Section 401

Section 401 of the CWA requires that any person applying for a federal permit or license, which may result in discharge of pollutants into waters of the United States, must obtain a state water quality certification that the activity complies with all water quality standards, limitations, and restrictions. Certification or a waiver under Section 401 is required prior to other federal agency authorization. This certification is required prior to construction and is only applicable during construction activities. The authority to certify projects has been delegated to local Regional Water Quality Control Boards, which in this case is the LARWQCB. The Project involves the construction of three dry-weather flow diversions at Alhambra, Eaton, and Rubio Washes – all of which are considered waters of the United States; therefore CWA 401 certification is required. The Project must be designed in such a way that will comply with

applicable water quality standards, effluent limitations, new source performance standards, toxic pollutants restrictions and other water quality requirements of State law (USEPA).

**Appendix L** includes documents related to the CWA 401 approval process. To receive certification under CWA Section 401, an application must be completed and submitted to the LARWQCB. An accurate description of the project, including the purpose and final goal of the project must be included along with completed design plans. Additionally, a detailed description of all measures to be taken to prevent the project from adversely affecting the water quality and beneficial uses of the three washes must be included.

Once the application is submitted, the LARWQCB has 30 days to notify the applicant regarding the completeness of the application. If the application is incomplete, the material must be resubmitted and another 30 days are used to review the revised application. If the applicant does not hear back within 30 days then the application is assumed to be complete. Once the application is complete, the LARWQCB is able to request additional information as they see necessary. The LARWQCB has up to one year to make a decision and a minimum 21 days must be provided for public comment prior to approval (23 CA ADC § 3855).

## 9.5 General NPDES Permit No. CAG994004

The General Waste Discharge Requirements/NPDES Permit for Discharges of Groundwater from Construction and Project Dewatering to Surface Waters in Coastal Watersheds of Los Angeles and Ventura Counties (General NPDES Permit No. CAG994004) is intended to authorize discharges of treated or untreated groundwater generated from permanent or temporary dewatering operations or other applicable water discharges not specifically covered in other general or individual NPDES permits to the MS4 (LARWQCB, 2018). Dewatering may be necessary, as there is a potential for groundwater to be encountered during construction, especially at Eaton and Rubio Washes, where groundwater has historical high water levels less than 30 feet deep. If groundwater is encountered and dewatering is necessary, a permit will be required. It must be demonstrated through the application process that the dewatered groundwater will not cause, have the reasonable potential to cause, or contribute to an in-stream excursion above any applicable state or federal water quality objectives/criteria or cause acute or chronic toxicity in the receiving water.

If dewatering is necessary at the site and it is more beneficial to discharge to the wash, as opposed to the sewer, SGVCOG will need to submit a Notice of Intent (NOI) to the LARWQCB. If the discharge is allowable, LARWQCB will notify the applicant that the discharge is permitted under the terms and of Order No. R4-2018-0125 and prescribe a monitoring and reporting program.

A complete NPDES Application shall be filed at least 45 days prior to the commencement of the discharge. Upon request, SGVCOG may need to provide any additional information deemed necessary to determine whether the discharge meets the criteria under the Order. SGVCOG must also obtain and analyze a representative sample of the groundwater using appropriate methods. Analytical results must be included with the application. Standards that are to be met are specified in the Order, which is included in **Appendix M**. Additionally, as the State Water Resources Control Board encourages the conservation or reuse of wastewater. Information regarding the feasibility of conservation, reuse, injection of the groundwater, and/or alternative disposal methods must be indicated through the application process.

A complete application shall include the following:

1. Completed NOI Form
2. Feasibility study on conservation, reuse, injection of the groundwater, and/or alternative disposal methods
3. Description of the treatment system
4. Type of chemicals that will be used (if any) during the operation and maintenance of the treatment system
5. Flow diagram of the influent to the discharge point
6. Preventive maintenance procedures and schedule for the treatment system
7. Treatment system to be used for removing toxic pollutants from the wastewater (if applicable)
8. Demonstration that the Discharger has considered sewerage, infiltration, re-use, or other discharge options and that it is infeasible to discharge to the sanitary sewer system or to re-use the dewatered groundwater

Additional requirements pertain to creekside construction dewatering operations; however do not apply to the Project in question. **Appendix M** provides more information regarding General NPDES Permit No. CAG994004 and includes a NOI Form.

## 9.6 Division of State Architect

The diversion proposed at Alhambra Wash may involve coordination with Rice Elementary School if work is conducted within the school property, in which case the Project will require approval by the DSA. This alternative is not presented in this report, and will only be necessary if LACSD determines additional off-line storage is necessary. DSA reviews construction projects under its jurisdiction, which includes K-12 public schools and community colleges, for Title 24 compliance. Plan reviews and construction oversight by DSA mostly concern structural safety governed by the Field Act contained in the California Education Code section 17280 for K-12 public schools. Various forms associated with DSA approval are provided in **Appendix N**. The Project will require an access, fire safety, and structural review if work is done within the school. DSA approval process requires the following items to be submitted:

- Required forms/documents
- Plan review fees
- Construction plans and specifications
- Structural calculations
- Geotechnical investigations, and
- Energy compliance documentation

In addition to approval prior to construction, a DSA-certified inspector must also oversee construction for the portion of the work within the DSA jurisdiction. The inspector must be at the job site full time and an on-site office must be provided by the contractor. The approval process includes an approximate plan review time of at least 90 days. Submittals must be in accordance with all requirements identified on

their checklist and provided in **Appendix N** so that the approval process is completed in a timely manner. DSA is not as familiar with underground stormwater projects as compared to more typical school construction. It has been found that DSA may issue an exemption if the surface is not impacted and proposed structures do not impact the functionality of the school.

## 9.7 LACFCD Connection Permit

The Project will divert runoff from Alhambra, Eaton, and Rubio Washes, all of which are operated and maintained by LACFCD. A Connection Permit will be required prior to construction that will allow the SGVCOG to connect to and modify existing LACFCD facilities. The following items must be submitted to LACFCD's online platform (EPIC LA) prior to receiving the Connection Permit:

- Permit application
- Plan checking and inspection fees
- Construction/engineering plans
- As-built plans with the sketch of the proposed connection location
- Hydraulic model input and output
- Allowable discharge rate and Hydraulic Grade Line (HGL)
- Contractor's license information and insurance documents including the endorsement that names the County as additional insured
- Additional information for non-stormwater discharges (if applicable)

The guidelines for Connection Permits produced by LACFCD are included in **Appendix O**. A hydraulic analysis conforming to LACFCD requirements will be required for each diversion and ultimately be included in the Connection Permit application. The Section 408 Permit submittal, as described in **Section 9.1**, will be submitted and processed as part of the Connection Permit. LACFCD typically takes six to eight weeks to review each submittal. A minimum of two submittals should be anticipated. Additionally, once the Connection Permit requirements are satisfied, LACFCD will forward the submittal package to USACE for Section 408 approval.

### 9.7.1 LACFCD Use Agreement

Activity within LACFCD facilities, including construction, operation, and maintenance, will require a LACFCD Use Agreement, which will grant the Project operator access to LACFCD property for construction, operation, maintenance, sampling, monitoring, and repair associated with the Project. Acquisition of this agreement will be coordinated through the Permitting Division and Survey/Mapping and Property Management Division and will be reconciled during the LACFCD Connection Permit Process.

Additionally, the proposed improvements will require maintenance to ensure functionality and overall Project success. It has not been determined who will be responsible for maintenance at each of the sites. If SGVCOG, or any agency other than LACFCD, is identified as being responsible for maintenance, and said agency was not granted access via the Use Agreement obtained during the construction phase of the Project, then an additional Use Agreement will be required. It is beneficial to determine who will

be responsible for maintaining each site prior to obtaining the Connection Permit and completing the Use Agreement.

## 9.8 LACSD Connection Permit

The Project proposes three connections to sewer lines owned and maintained by LACSD and thus, requires coordination with LACSD. The Project, which is under the jurisdiction of LACSD District 15, is required to comply with the District's "Dry Weather Urban Runoff Diversion Policy" and "Guidelines for the Discharge of Rainwater, Stormwater, Groundwater and Other Water Discharges" provided in **Appendix P**. These requirements are explained in further detail below.

The process of obtaining a Connection Permit will vary for all three locations as the sites differ in regards to site ownership. The sewer connection proposed for the Alhambra Wash site is located in the public right-of-way; the connection for the Eaton Wash site is located within the LACFCD right-of-way; and the connection for the Rubio Wash is located on private property. These constraints add variability to the permitting process and thus, step by step instructions will not be provided in this report; however it is recommended that coordination with LACSD begin as early as possible.

### 9.8.1 Requirements for Discharge of Dry-Weather Flows

LACSD policy states that year round, 24-hour per day discharge of dry-weather flows may be allowed if the flows are not adversely impacted and are identified as having an environmental benefit (LACSD, 2014). Otherwise, discharge may be limited to May 1<sup>st</sup> through September 30<sup>th</sup> and may further be limited to off peak hours. Additionally, the discharge rates will generally be limited to ensure all downstream systems do not flow at more than  $\frac{3}{4}$  depth. The intent of this Project is to be allowed year round, up to 24-hour per day discharge, depending on the alternative and site.

Dry-weather flow discharge requirements also state that discharge must be pumped into the sewer, as opposed to being gravity-controlled. Furthermore, a check valve must be placed along the force main to ensure that wastewater does not backflow into the storm drain diversion system. Pumped flows must further be treated to remove debris larger than  $\frac{3}{8}$ <sup>th</sup> of an inch. LACSD also requires the installation of an effluent flow meter to measure the quantity of discharge. The meter must have a non-resettable totalizer and an instantaneous recorder to assist in peak flow compliance determination.

The District requires that the area tributary to the diversion point must be provided. An illicit discharge investigation is required to determine if any significant inappropriate waste streams are tributary to the diversion. The permittee, in this case SGVCOG, may also be required to exercise procedures to minimize the generation of unnecessary dry-weather flows and to implement Best management Practices (BMPs) to minimize or eliminate nuisance flow and pollutants. As a regional dry-weather project, it is unlikely that LACSD will require these elements. Additionally, jurisdictions within the Project's drainage areas implement Minimum Control Measures (MCMs), which are non-structural BMPs, to minimize pollutant loading.

A gas detector must also be installed and able to shut down operations upon reaching a 20% Lower Explosive Limit (LEL). A rain gage must also be provided in close proximity to the low flow diversion system. The rain collector must be capable of measuring 0.1 inches of rain and upon sensing 0.1 inches of rain, the system must automatically shut off power to the pump and remain off until rain has ceased

for a minimum of 24 hours. The requirements may change, as these sites will be the first regional dry-weather facilities that will be permitted by the LACSD. It is anticipated that the Project will need to receive information from rain gages throughout the watershed, not only onsite, as storm flows upstream in the watershed will impact channel flows being diverted and LACSD cannot receive additional flows during rain events. Periodic sampling of dry-weather flows and self-monitoring reports are required following permit allocation.

In summary, LACSD requires that the agencies responsible for the stormwater collection system, in this case, SGVCOG, to meet the following:

- Obtain all proper permits from LACSD
- Utilize a pump system
- Install equipment to remove gross solids (i.e. remove particles larger than 3/8-inch)
- Install a check valve, flow meter, rain gage, and gas detector
- Conduct periodic sampling
- Pay all required fees, and
- Comply with the Districts "Wastewater Ordinance", including local effluent limitations

## 9.9 Right-of-Way Valuation

Each of the Project sites have been inspected and analyzed to assess right-of-way requirements and to identify a real property cost assessment. The Project parcels have been analyzed based on their highest and best use as of June 2019. Information contained in this section is a "valuation service," not an "appraisal service," characterized as services pertaining to aspects of property value. A detailed report is included in **Appendix Q**. Subsections are included below for Alhambra and Rubio Washes, as these two sites require the use of private property under the worst-case scenario. The worst-case scenario, in regards to land required, was considered, which is associated with off-line storage, as illustrated in **Section 4**. Temporary construction easements will be required for all three sites, which are not detailed in this section, but are discussed in **Appendix Q**. An additional subsection is included below, which details procedures to follow if an acquisition is necessary.

### 9.9.1 Alhambra Wash

Improvements to Alhambra Wash are proposed within the channel and within the parcel to the east of the channel under the alternative that requires the most land, which is associated with off-line storage. The parcel adjacent to the channel (Assessor Parcel Number [APN] 5279-033-801) is owned by SCE. Off-line storage improvements, along with the pump system, are anticipated along the north side of the parcel, adjacent to Rush Street. Details regarding the parcel and analyzed footprint are included in **Appendix Q**.

Assuming the area is to be acquired as a subsurface easement, the surface use would be limited. SCE was approached in 2017 to sell the property for development of a hotel, but the offer fell through for unknown reasons, based on coordination with SCE. The footprint of the proposed hotel was located outside the LACFCD easement area with the parking proposed on top of the channel (see site plan in appendix). According to SCE, there are no current plans for this parcel.



Under the worst-case scenario, the proposed improvements would encumber a large portion of the net buildable land area along the entire street frontage of Rush Street. Street frontage for commercial development is placed at a premium and loss of frontage may result in reduced functional utility for the remaining land area, resulting in potential damages to the remainder and/or warranting a full acquisition of the parcel for the Project. Comparable land values in the market area range from \$35 to \$73 per square foot, with an average of \$45 per square foot. Therefore, under the worst case scenario, a total fee acquisition of the property would be approximately \$1,303,000.

If it is assumed that the Project area could be acquired in easement (subsurface) and it was determined future development or functional utility of the site would not be affected by the Project, the estimated value of the acquisitions for the Project would be calculated based on an estimated total easement area of 15,000 square feet, resulting in a cost of approximately \$337,500.

### 9.9.2 Rubio Wash

Improvements to Rubio Wash are proposed within the channel and within the parcel to the east of the channel under all considered alternatives, with the greatest impact being associated with off-line storage. The channel in the vicinity of the Project is privately owned and LACFCD has an easement for use for the channel. The parcels adjacent to the channel (APNs 8595-017-010, -011, -018, and -019) are owned by a private owner. Off-line storage improvements, along with the pump system, are anticipated along the east side of the parcels, adjacent to Rosemead Boulevard. Details regarding the parcels and analyzed footprint are included in **Appendix Q**.

Assuming the area is to be acquired as a subsurface easement, the surface use would be limited. The property was listed for sale with Coldwell Banker Commercial throughout 2017 for indicated asking prices ranging from \$1,888,000 to \$3,000,000 and is no longer an active listing. Site plans were obtained from CoStar indicating a proposed retail development on the site. Copies of the site plan are included in **Appendix Q**. It is unknown if the entitlement process was started or continues for the proposed development at this time.

Under the worst case scenario, the proposed improvements would encumber a large portion of the net buildable land area along Rosemead Boulevard frontage. Street frontage for commercial development is placed at a premium and loss of frontage may result in reduced functional utility for the remaining land area, resulting in potential damages to the remainder and/or warranting a full acquisition of the parcels for the Project. Based on the site plans, the majority of the proposed project improvements would be within the designated parking area under the development scenario. Comparable land values in the market area range from \$30 to \$70 per square foot, with an average of \$40 per square foot. Therefore, under the worst-case scenario, a total fee acquisition of the property would be approximately \$2,235,000.

If it is assumed that the Project area could be acquired in easement (subsurface) and it was determined future development or functional utility of the site would not be affected by the Project, the estimated value of the acquisitions for the Project would be calculated based on an estimated total easement area of 15,000 square feet, resulting in a cost of approximately \$300,000.

### 9.9.3 Acquisition Procedures

Regardless of the type of acquisitions required for the Project (fee, easement, temporary easement, permits, etc.), the following procedures are typically followed:

- Official acquisition exhibits need to be finalized (legal descriptions and plats)
- Obtain preliminary title reports for all properties involved
- Perform an official survey of each property (Alta Survey) recommended
- Notification to the owners via a “Notice of Decision to Appraise”
- Begin the appraisal process based on the following:
  - Notification to the owners via a “Notice of Appraisal Inspection”
  - Inspection of the subject properties
  - Review and investigate the respective land jurisdictions
  - Perform a Highest and Best Use Analysis on the subject properties
  - Value the subject properties using all applicable approaches to value
  - Value the part(s) acquired
  - Value the remainder parcel to estimate benefits and/or damages, if any
  - Complete an Appraisal Report and Appraisal Summary Statement
- Approach the property owners with an offer of compensation

### 9.10 Local Requirements

In addition to the permits and approvals discussed above, the Project must be covered under applicable local permits. Electrical, Encroachment, Excavation, Mechanical, and/or Right-of-Way Construction Permits may be required prior to constructing the Project. Coordination with the Cities of El Monte and Rosemead will be required to identify which permits are applicable, as the Projects take place in these jurisdictions. These permits are generally investigated and acquired by the Project contractor.

## 10. Additional Treatment Alternatives

The concepts summarized in **Section 4** (based on the LRS approach) were submitted to LACSD with the flow analysis (**Section 6**) to determine if the proposed discharge rates would be accepted based on the sewer network and treatment system capacities. During this review process, LACSD discovered that the Whittier Narrows WRP does not have sufficient capacity to treat flows captured at Alhambra, Eaton, and Rubio Washes. LACSD explained that the Whittier Narrows WRP has historically operated as a scalping plant, as wastewater flows in the influent tributary sewer are higher than the plant capacity. The Whittier Narrows WRP retains flows within the plant's capacity, while the remaining flows go downstream to the JWPCP. The WRP capacity also depends on the influent water quality, which has changed due to water conservation measures. Whittier Narrows WRP could not take on these additional flows without plant upgrades.

Diverting dry-weather flows to the sanitary sewer means they will end up at JWPCP, which is outside of the groundwater basin. The Main San Gabriel Basin Watermaster had verbally agreed that the Project would be approved by them through the SB 485 consultation, as it had been assumed the water would remain within the basin. These findings resulted in the Watermaster identifying a potential discharge fee, as summarized in **Section 7.2**.

This section includes three alternative approaches considered for Alhambra, Eaton, and Rubio Washes due to the abovementioned findings. The alternative approaches aim to accomplish the original regulatory goal of reducing bacteria loading in dry-weather flows. The purpose of these alternative approaches is to identify opportunities to keep dry-weather flows within the basin as opposed to having them directed into the sanitary sewer and leaving the basin. These alternatives vary from those presented in **Section 4**, while some of the components described in **Section 5** remain applicable. Each alternative approach will feature a diversion structure, pump, and connection to sanitary sewer. The connection to sanitary sewer is necessary for infrastructure backwash. The alternative approaches may also include storage (in-line or off-line).

The following three approaches are described in this section, along with information pertaining to the treatment approach, site requirements, O&M, cost, permitting, pros and cons, and next steps.

1. Advanced treatment for release
2. Title 22 treatment for discharge into existing recycled water system
3. Advanced treatment for groundwater injection

### 10.1 Treatment Alternative T1: Advanced Treatment for Release

Treatment Alternative T1 includes advanced treatment of dry-weather flows from each site prior to being released back to the channel. The main goal of the Project is to address bacteria loading in each of the three washes. **Figure 10-1** illustrates the treatment schematic associated with Treatment Alternative T1. The treatment system would need to be effective at removing bacteria, which would likely be comprised of either Ultra Violet (UV) or ozone treatment.

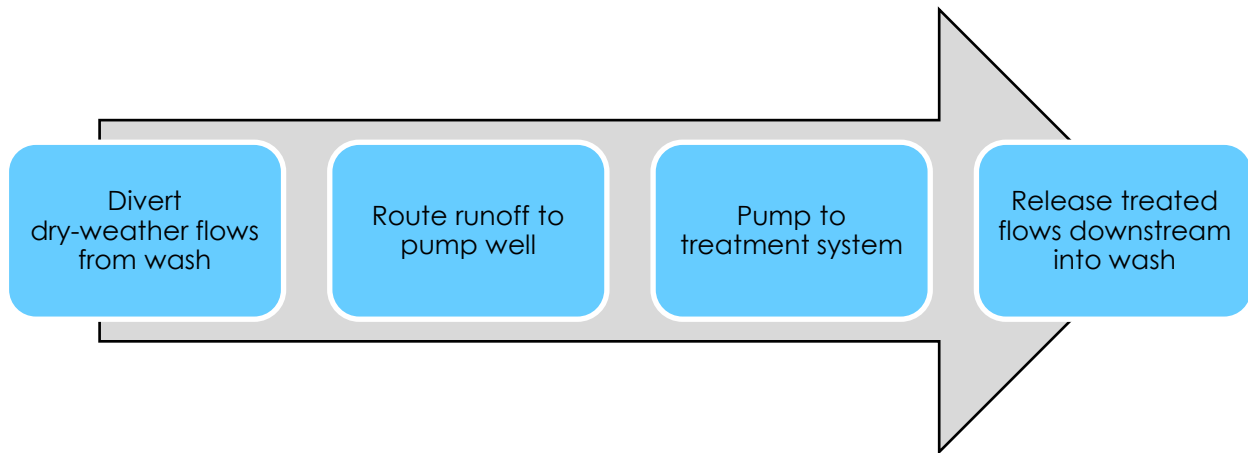

**Figure 10-1 Treatment Alternative T1 Project Concept**

Centralized and decentralized alternatives were considered under this approach. It would be more cost-effective to have a separate treatment system at each location to avoid extensive amounts of piping between facilities. The treatment system is not too large, and would easily be able to be located at the Alhambra Wash and Rubio Wash sites in the adjacent open space (see easement and acquisition description in **Section 9.9**).

### 10.1.1 Treatment Approach

UV and/or ozone can be used to actively remove microbial organism from stormwater if coupled with a pretreatment device. The pretreatment device must remove sediments and suspended solids in addition to trash and debris. The following pretreatment device types could be utilized upstream of the treatment system:

- Media filter
- Membrane filter
- Fine mesh screen

#### UV Treatment

UV lamps will be used to expose flows to UV radiation, which will kill bacteria. The UV treatment equipment will be housed within a small enclosure or building. UV kills microorganisms when UV rays strike the cell. UV energy penetrates the outer cell membrane, passes through the cell body, and disrupts its DNA, which prevents reproduction. UV treatment does not alter water chemically; nothing is being added except energy. Microorganisms are not removed from the water, but deactivated. The degree of deactivation is directly related to the UV dose applied to the water. The dosage is a product of UV light intensity and exposure time, measured in watt per square centimeter. The required UV dosage is based on existing water quality and desired discharge quality. Additional water quality data and testing will be required to determine the appropriate dosage and pretreatment system.

UV treatment is most effective when levels of turbidity and suspended solids are low, as cloudy water prevents UV rays from penetrating the full water column. Pretreatment will be used to remove the suspended solids, which could otherwise shield the bacteria, allowing it to move through the system

without being exposed to the UV radiation. UV treatment does not provide any residual effects downstream. It is possible that bacteria could regrow within the washes downstream of treatment. The treatment system will require a connection to the sanitary sewer for backflushing.

UV treatment requires less extensive maintenance as compared to ozone treatment, as it mostly includes changing a light with no mechanical parts. Some drawbacks are that it is not effective when high turbidity and suspended solids exist. UV treatment also does not leave a residual for continued treatment downstream (one point of treatment). UV treatment does not prevent regrowth.

## Ozone Treatment

Diverted dry-weather flows will be exposed to ozone, which is a disinfectant that to some extent oxidizes certain contaminants found in the water column. The ozone treatment system would be housed within an enclosure or a small building. Ozone comes into contact with the microorganism's cell wall and a reaction called oxidative burst occurs which creates tiny holes in the cell wall which causes the cell to lose its shape. The cell dies after ozone collisions occur due to the damaged cell wall.

Ozone will be generated on site and the amount generated will be based on influent water quality and desired effluent quality. If an ozone dosage higher than what is necessary is applied then there may be residual ozone in the water column, which is then discharged downstream. This will continue the treatment process downstream. In most instances this is not harmful, as the half-life of ozone is very short. However, it is recommended that an ozone treatment system include an ozone meter, which will monitor the system and kill residual ozone to a predefined level prior to discharge (5-10 percent is desirable).

Ozone treatment is effective at killing bacteria and operates more effectively than UV when high turbidity and suspended solids exist. Some drawbacks of ozone include its reactive and corrosive nature and the potential that some byproducts may be carcinogenic. Ozone treatment does not prevent regrowth.

### 10.1.2 Site Requirements and Existing Constraints

UV and/or ozone treatment systems require some space aboveground for the housing of treatment equipment. The pretreatment system may be located above ground or in subsurface vaults. Both systems will require a mechanical skid for the treatment components. The UV system will include UV lamps, which the water flows through. The ozone system will include ozone storage, an injection system, and a system for flows to go through as they are injected. The systems would each benefit with flow equalization to normalize the treatment flow rate and allow sediment particles to settle out. The system sizing will depend on the manufacturer, who can typically work with the space available, especially at Alhambra and Rubio washes.

### 10.1.3 Operation and Maintenance

The treatment systems each require unique O&M and are dependent on site-specific influent water quality, which is currently unknown. General maintenance is summarized below:

- Pretreatment system
  - Regular inspection to determine if cleaning is necessary
  - Remove accumulated sediment as necessary
  - Replace filter/screen if clogging is observed and at a frequency indicated by the manufacturer
  - Membrane filter cartridges will need to be removed, rinsed, and reinstalled at least once annually and replaced every five years
- UV system
  - Clean quartz sleeve surrounding UV lamps
  - Quartz parts require chemical cleaning if they become fouled
  - Automatic wiper system operates when the system is running and must be replaced approximately once per year
  - UV lamp replacement every 8,000 to 10,000 hours of run time, or once per year
- Ozone system
  - Ozone injection skid will require maintenance related to the pumps
  - Oxygen concentrator within treatment unit (produces ozone) requires service every 12,000 to 30,000 hours to filters, solenoid valves, and other appurtenant parts
  - Sieve material (within oxygen concentrator) will require replacement every four to five years
  - Regular inspection for leaks

#### 10.1.4 Similar Projects and Probable Cost

Probable costs to implement Treatment Alternative T1 will vary depending on several factors. Including whether a centralized or decentralized system is selected, water quality, UV versus ozone treatment, pretreatment approach, and land acquisitions, among other factors. **Table 10-1** summarizes implementation efforts using a similar approach within Los Angeles County. The table identifies the similar project, year it was constructed, capacity, and cost. **Section 6** identifies the anticipated capacity of each site depending on whether storage is used or not. The capacity of each system individually varies from 630 to 1,436 gpm (0.9 to 2.0 Million Gallons per Day [MGD]), with a cumulative capacity ranging from 2,430 to 3,600 gpm (3.5 to 5.2 MGD).

**Table 10-1 Similar Projects to Treatment Alternative T1**

Project	Size	Year	Cost	Notes
Agoura Hills' Medea Creek	2.4 MGD	2021	\$8,200,000	In design phase (probable cost)
Ballona Creek Watershed LFTF-1	29 MGD/ 6 MGD	2024	\$19,500,000	In design (probable cost) – 29 MGD pump station, 6 MGD ozone treatment
Ballona Creek Watershed LFTF-2	1.3 MGD	2024	\$6,100,000	In design (probable cost) – ozone treatment
Malibu's Legacy Park	2 MGD	2010	\$35,000,000	Includes development of 19-acre park with detention facility and ozone treatment
Malibu's Paradise Cove	1 MGD	2010	\$1,000,000	Filtration and UV treatment

### 10.1.5 Permitting

Similar to the alternatives discussed in **Section 4**, Treatment Alternative T1 will be subject to most of the permits/approvals described in **Section 9**, including land acquisition. Other permits and approvals will not be necessary as part of this alternative approach.

### 10.1.6 Pros and Cons

**Table 10-2** summarizes the pros and cons associated with Treatment Alternative T1, as it compares to the LRS approach (**Section 4**) and the other treatment alternatives presented in **Section 10**. The pros and cons between UV and ozone treatment are incorporated into the narrative discussion in **Section 10.1.1**.

**Table 10-2 Pros and Cons for Treatment Alternative T1**

Pros	Cons
<ul style="list-style-type: none"> <li>➤ Water would remain in the basin as it does under existing conditions, reaching natural portions downstream in Rio Hondo</li> <li>➤ LACSD and Watermaster fees would not apply (small LACSD fee in association with backwashing with UV treatment)</li> <li>➤ Least expensive alternative approach</li> </ul>	<ul style="list-style-type: none"> <li>➤ Placement alternatives at Eaton Wash would require additional consideration</li> <li>➤ Higher upfront capital cost as compared to LRS approach</li> <li>➤ Stringent sampling regulations</li> <li>➤ Specialized maintenance for treatment system</li> <li>➤ Regrowth could occur downstream in the wash after treated water is discharged</li> </ul>

### 10.1.7 Next Steps

If the Treatment Alternative T1 approach is of interest to the Cities, the following steps would be necessary to further assess feasibility and cost:

1. Identify system placement at Eaton Wash and confirm placement at Alhambra Wash and Rubio Wash
2. Determine whether UV or ozone is preferred, or make this open to contractor with performance specification
3. Coordinate with potential vendors to identify data needs and sizing
4. Perform water quality sampling to define pretreatment levels and required UV dosage
5. Coordination with LARWQCB to confirm deviation from LRS approach.

## 10.2 Treatment Alternative T2: Title 22 Treatment for Discharge into Existing Recycled Water System

Treatment Alternative T2 involves the treatment of dry-weather flows and connection to existing recycled water infrastructure for use as recycled/non-potable water, as illustrated in **Figure 10-2**. Treatment of these flows would be consistent with the regulations set forth by Title 22 of California’s Water Recycling Criteria, as the water will be blended with existing recycled water sources and must match the water quality of the recycled water system.



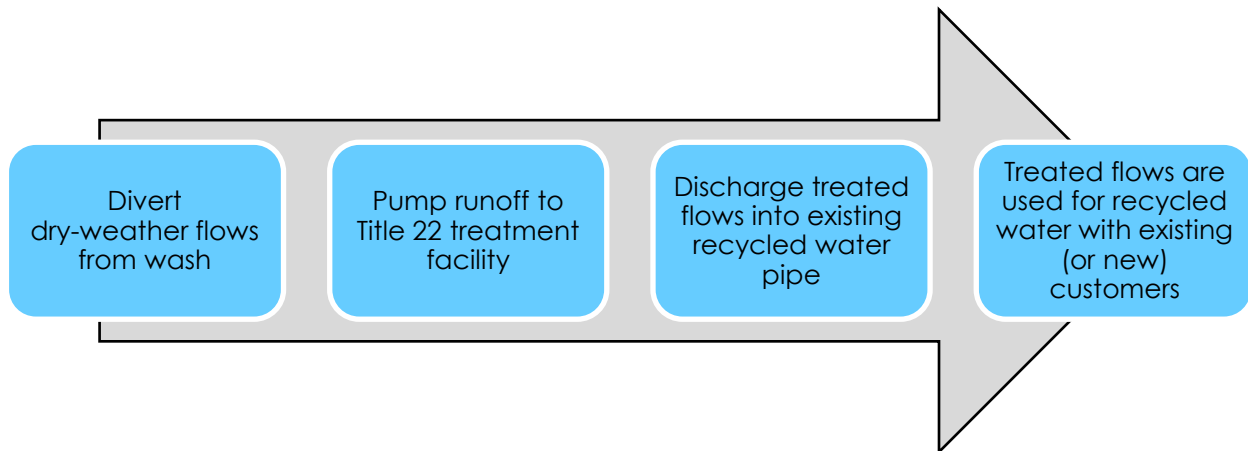

**Figure 10-2 Treatment Alternative T2 Project Concept**

The Whittier Narrows WRP treats wastewater from the Upper San Gabriel Valley and delivers it to a wholesale water purveyor – the Upper San Gabriel Valley Municipal Water District (USGVMWD). Currently, the Whittier Narrows WRP operates at capacity and is unable to meet USGVMWD’s recycled water demands. Treatment Alternative T2 would provide additional supply to USGVMWD in an effort to meet or exceed the recycled water demand. If the supply exceeds the demand, then new recycled water customers would be necessary. The T2 approach proposes to deliver treated dry-weather runoff into the existing recycled water system managed by the USGVMWD, as USGVMWD has existing infrastructure in place, along with clients. This represents a more cost-effective approach, in terms of both upfront capital and ongoing operational costs, as compared to establishing a new recycled water provider. USGVMWD would pay for the recycled water, similar to how their system currently operates.

This treatment approach could include three separate treatment facilities at each of the three washes or a single facility at a centralized location. Both options are considered in the following subsections.

### 10.2.1 Treatment Approach

Water recycling is broken down into the following different categories:

1. Non-potable reuse: recycled water for purposes other than drinking, including irrigation, agriculture, and industrial uses.
2. Indirect potable reuse: treated water sent to a natural water body, either on the surface or underground, before it is extracted again for drinking water.
3. Direct potable reuse: wastewater is highly treated and becomes a drinking water source.

Treatment Alternative T2 falls under the non-potable reuse category, as the dry-weather runoff captured will be treated for non-potable uses, as it will be combined with the existing recycled water system. The existing USGVMWD recycled water system in the Project area delivers water to schools, parks, golf courses, medians, corporate offices, commercial properties, and a nursery.

Title 22 includes non-potable reuse requirements based on the treatment of wastewater, while the Project will be capturing dry-weather runoff, which has significantly different water chemistry as compared to wastewater. Conventional wastewater treatment facilities treat to a secondary level before



discharging downstream. This includes removing floating and suspended solids (primary) along with biological methods to reduce chemical and biological loadings (secondary). Recycled water must be treated to a tertiary level, achieving a higher level of disinfection than typical wastewater treatment. According to Title 22, wastewater must be both filtered and disinfected before becoming recycled water for non-potable use, meeting the following standards:

- Filtration requirements:
  - Average daily turbidity less than 2 NTU
  - Effluent cannot exceed 5 NTU more than 5% of the time
  - Effluent cannot exceed 10 NTU at any time
  - Coagulant must be added if the influent to the filter exceeds 5 NTU for more than 15 minutes or 10 NTU at any time
- Disinfection requirements:
  - Filtered wastewater has been disinfected by either:
    - Chlorine disinfection process with chlorine residual that provides 450 milligram-minutes per liter under a minimal contact time of 90 minutes, which corresponds to a residual of 5 mg/L OR
    - Disinfection process that has been demonstrated to inactivate and/or remove 99.999% of the plaque forming units of F-specific bacteriophage MS2, or polio virus
  - Median total coliform count in disinfected water cannot exceed an average Most Probable Number (MPN) of 2.2/100 mL, and no more than one sample per month can read over 23 MPN/100mL

There are several treatment train variations that can be used to meet Title 22 requirements, keeping in mind that urban runoff contains constituents not typically found in wastewater, such as metals. Advanced treatment may include Granulated Activated Carbon (GAC) units with chlorination, UV, or ozone. The treatment system could also include ceramic ultra-filtration. The treatment train configuration and sizing will depend on influent water quality and necessary treatment flow rates. A centralized treatment system could be used to treat flows from the three sites, which would require a large pipe network, or individual treatment systems could be used at each site, which would require more distributed maintenance. Each configuration may benefit from storage as a way to equalize the treatment flow rate. This could be accomplished with in-line storage within each wash or a storage system at the treatment facility (off-line).

### 10.2.2 Site Requirements and Existing Constraints

Treatment facilities can range in size depending on a variety of factors, including treatment capacity (flow rate), selected treatment train, administrative staffing needs, and more. A packaged system could be used, which contains the treatment components in one package, or a treatment train could be designed based on preferred equipment for each treatment process. Equipment will need to be enclosed, typically within a building or shelter. The system will require a diversion and pump station, as described in **Section 5**. Flow equalization (storage) may be beneficial or necessary depending on the selected system. The treatment system will also need to be connected to the sanitary sewer to discharge backwash from the treatment process.

Vacant property exists near the Alhambra Wash and Rubio Wash diversion sites, which may be purchased to house a treatment facility (see **Section 9.9** for acquisition information). Both sites could be used as part of a distributed approach, with Eaton Wash having a treatment facility nearby or shared with one of the other sites. Alternatively, a centralized treatment facility may be located at Alhambra or Rubio Wash or between the three diversion sites on a vacant property (to be purchased) or on existing property owned by one of the Cities.

In addition to sizing requirements, additional constraints exist. Both the centralized and decentralized options will require pipelines to deliver water. The centralized option will require more than three miles of pipelines to divert dry-weather flows from each individual wash to a centralized treatment facility. From there, the treated water will be delivered, via additional pipelines, to the existing recycled water lines owned and maintained by USGVMWD. The decentralized option will similarly require pipeline between each of the three washes and USGVMWD's existing system.

Additional research and explorations will be necessary to determine where the pipelines can be installed. The pump, or series of pumps, needed to deliver flows will be much larger than those proposed under the LRS approach, as the headloss will be much higher due to elevation changes and the distance flows are being pumped. The pipelines will cross several intersections and potentially the washes. Design of the alignment will have to consider the various utilities present, overall topography, underlying soil conditions, jurisdictional preferences, and any permitting requirements. Pipe installation and associated traffic control will impact costs.

### 10.2.3 Operation and Maintenance

O&M will vary depending on the type of treatment system selected. Several system components, including fully packaged systems, are described as "fully automated needing auditors not operators." This means that the system will run without any attendants however, should be checked on a consistent basis to verify components are functioning properly and water quality standards are met. Frequency of these audits will vary based on each system's treatment flow rate and direction from regulating agencies. Monitoring and reporting will be necessary to demonstrate the system is meeting regulatory requirements.

It is recommended that the Cities determine who will be responsible for maintenance prior to final design, such that those maintaining the system can provide input as to any manufacturer/part preferences and available equipment for maintenance. This may not be as critical if a third party will be hired to perform maintenance. O&M of the diversion, pump, sewer connection, and other appurtenances are described in **Section 7**.

The following general O&M can be expected at a treatment facility related to the selected equipment:

- Component inspection and servicing
- System cleaning
- Valve inspection and maintenance (periodic replacement)
- Chemical treatment

### 10.2.4 Similar Projects and Probable Cost

Probable costs to implement Treatment Alternative T2 will vary depending on several factors, including whether a centralized or decentralized system is selected, water quality, preferred treatment system, packaged versus designed system, and land acquisitions, among other factors. **Table 10-3** summarizes implementation efforts using a similar approach within Los Angeles County. The table identifies the similar project, year it was constructed, capacity, and cost. **Section 6** identifies the anticipated capacity of each site depending on whether storage is used or not. The capacity of each system individually varies from 630 to 1,436 gpm (0.9 to 2.0 Million Gallons per Day [MGD]), with a cumulative capacity ranging from 2,430 to 3,600 gpm (3.5 to 5.2 MGD).

**Table 10-3 Similar Projects to Treatment Alternative T2**

Project	Size	Year	Cost	Notes
LB-MUST	2 MGD	2020	\$24,000,000	In design phase (probable cost) – includes building and treatment system, but not piping for delivery
Regional Recycled Water Advanced Purification Center	0.5 MGD	2020	\$17,000,000	Phase 1 of project construction costs using JWPCP’s cleaned wastewater
SMURRF	0.5 MGD	2000	\$12,000,000	Title 22 with walk through building

### 10.2.5 Permitting

Similar to the alternatives discussed in **Section 4**, Treatment Alternative T2 will be subject to most of the permits/approvals described in **Section 9**, including land acquisition. In addition, this alternative may require permits/approvals related to the alignment of piping. Permits/approvals may be required from the Los Angeles Department of Public Health (LADPH) under the Cross Connection Program, Caltrans for encroachments, and approvals from the various Cities the project pipelines are aligned through. Coordination will be required with USGVMWD to understand any specific requirements they may have.

#### 10.2.5.1 Los Angeles County Department of Public Health

LADPH’s Cross-Connection and Water Pollution Control Program is responsible for the oversight of new and converted recycled water re-use sites from planning stage through final approval, ultimately approving the safe use of recycled water. Recycled water is limited to use that is approved by the California Department of Public Health, the LARWQCB, and LADPH. Recycled water may only be used in those areas approved by the local water utility company, in this case, USGVMWD. Approval by the local water utility company will only be granted upon the fulfillment of all requirements of the applicable regulatory agencies.

**Appendix R** includes the application for submitting the Project to LADPH, along with Guidelines for Pipeline Construction and Installation – for the Safe Use of Recycled/Reclaimed Water. The guidelines identify implementation requirements, pipe separation, pipeline materials and identifications, and backflow protection. Once design plans have been prepared, an application along with two hard copies and one electronic copy of the plans, and payment must be delivered to LADPH. The LADPH reviewer will work with the applicant to confirm requirements are met and will stay involved in the project into construction to satisfy inspection and monitoring requirements.



**10.2.5.2 Caltrans Encroachment Permit**

A Caltrans encroachment permit may be necessary if construction occurs within Caltrans right-of-way. This may occur depending on pipe installation alignment in association with Treatment Alternative T2, specifically if a centralized system is implemented. **Appendix S** includes the Standard Encroachment Permit Application and checklist, which must be completed and submitted along with supporting documentation, such as plans, location map, environmental documentation, fees, and other items. Several other reference and guidance documents are available on the Caltrans website. Caltrans is required to either approve or deny the application within 60 calendar days. The Caltrans reviewer will work with the Project applicant to refine the submittal package until it is ultimately approved.

**10.2.6 Pros and Cons**

**Table 10-4** summarizes the pros and cons associated with Treatment Alternative T2, as it compares to the LRS approach (**Section 4**) and the other treatment alternatives presented in **Section 10**.

**Table 10-5** summarizes the pros and cons of selecting a centralized system over a decentralized system.

**Table 10-4 Pros and Cons for Treatment Alternative T2**

Pros	Cons
<ul style="list-style-type: none"> <li>➤ Water conservation benefit through use as recycled water within the basin</li> <li>➤ Will assist USGVMWD in meeting demands and may allow for additional customers</li> <li>➤ LACSD and Watermaster fees would not apply</li> <li>➤ Reduces bacteria loading through retention</li> </ul>	<ul style="list-style-type: none"> <li>➤ Potentially costliest alternative (centralized and decentralized options)</li> <li>➤ Much higher upfront capital cost as compared to LRS approach</li> <li>➤ Stringent sampling regulations</li> <li>➤ Prevents water from reaching natural channel portions downstream of Project on Rio Hondo</li> <li>➤ Specialized maintenance for treatment system</li> <li>➤ USGVMWD may or may not allow flows to be blended with existing network directly</li> </ul>

**Table 10-5 Pros and Cons for Treatment Alternative T2 – Centralized**

Pros	Cons
<ul style="list-style-type: none"> <li>➤ Treatment component O&amp;M at one location</li> <li>➤ Less expensive</li> <li>➤ Single acquisition/property needed</li> </ul>	<ul style="list-style-type: none"> <li>➤ Excessive piping required from diversion sites to treatment facility (pipe O&amp;M distributed across several jurisdictions)</li> <li>➤ Large pumps required to deliver flows to recycled water system due to headlosses</li> </ul>



### 10.2.7 Next Steps

If the Treatment Alternative T2 approach is of interest to the Cities, the following steps would be necessary to further assess feasibility and cost:

1. Coordination with USGVMWD:
  - a. Determine existing unmet recycled water demand in comparison to Project supply,
  - b. Assess Project interest and support,
  - c. Identify recycled water blending requirements, and
  - d. Evaluate opportunities for new services (if supply exceeds existing unmet demand).
2. Further evaluation to determine if a single centrally located treatment facility is preferred over multiple facilities (review of potential sites).
3. Coordination with LARWQCB to confirm deviation from LRS approach.

## 10.3 Treatment Alternative T3: Advanced Treatment for Groundwater Injection

Treatment Alternative T3 involves the treatment of dry-weather flows for injection into the ground for the purpose of groundwater recharge, as illustrated in **Figure 10-3**. This approach is a form of water recycling and would fall under the indirect potable reuse category described in **Section 10.2.1**. The injection wells would be considered Class V injection wells based on the USEPA classification and would further fall under the “Aquifer Recharge Wells and Aquifer Storage and Recovery Wells” category. This section assumes direct injection into aquifer, as opposed to gravity infiltration into groundwater (also known as drywells).

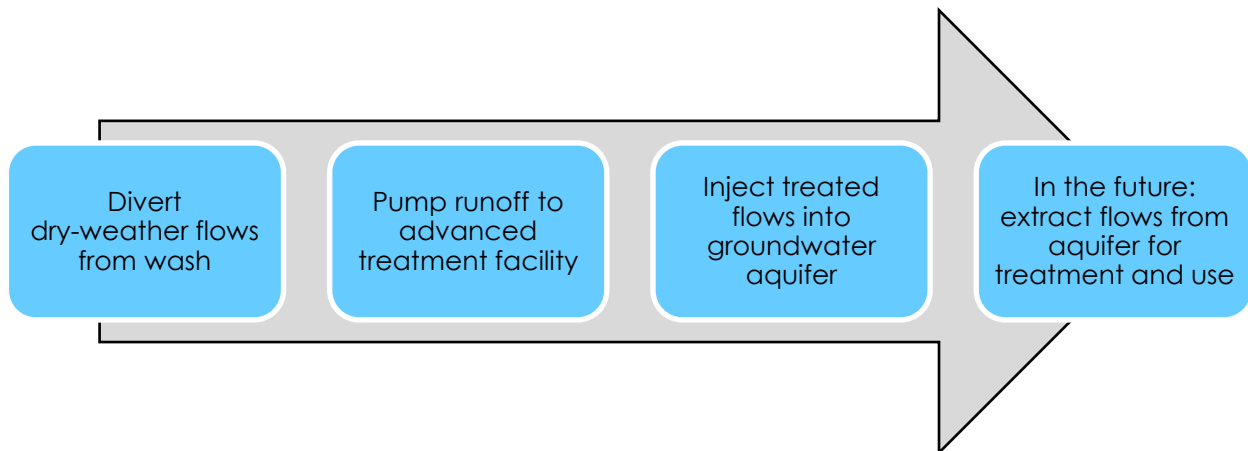

**Figure 10-3 Treatment Alternative T3 Project Concept**

### 10.3.1 Treatment Approach

Treatment Alternative T3 will likely require advanced treatment, greater than Treatment Alternative T2. Water injected directly into a drinking water aquifer must meet primary and secondary drinking water standards in an effort to protect the aquifer and preserve the quality of groundwater for future recovery. A more detailed exploration into the local aquifer depths and characteristics will be necessary before

determining the right level of treatment. The same advanced treatment standards do not apply if water is injected outside of the aquifer. The main difference between Treatment Alternative T3 and T2 is the destination of the treated water. Under this alternative, treated flows will be injected for groundwater recharge as compared to being delivered for recycled water. Under both treatment alternatives, flows will remain within the basin, such that the fees described in **Section 7.2** from the Main San Gabriel Watermaster would not apply, and will not be conveyed downstream to Rio Hondo.

**Section 10.2.1** summarizes the general treatment approach for this alternative, specifically related to packaged versus designed systems, while the treatment standard may be higher.

Once flows are treated, they will be conveyed to one or more injection wells which will pump the flows into the ground. Depth of injection will vary across the three sites and will be determined following additional geotechnical explorations to better characterize aquifer depths and conditions (hydrogeologic evaluation required). Explorations will include a pump or slug test with depth-specific wells, along with observation wells to observe lateral spread and mounding. Groundwater modeling may be necessary to determine how the injection will affect the hydrogeology depending on the location and depth of the potable water aquifer. Injection wells utilize pressure to push water into the ground at a faster rate. The injection process goes through perched groundwater layers into the confined or unconfined aquifer.

Each injection well will feature injection tubing encased by an inner casing, as illustrated in **Figure 10-4**. The inner casing will be perforated at the bottom to allow treated flows to be injected into the injection zone. Each injection well will feature two tremie pipes to allow for the pouring of concrete upon well abandonment. The inner casing and tremie pipes will be grouted in place and enclosed by a concrete protective casing. The injection well typically includes a well screen with a sand/gravel pack surrounding it. A pump may be located within the casing if water will be recovered from the same well.

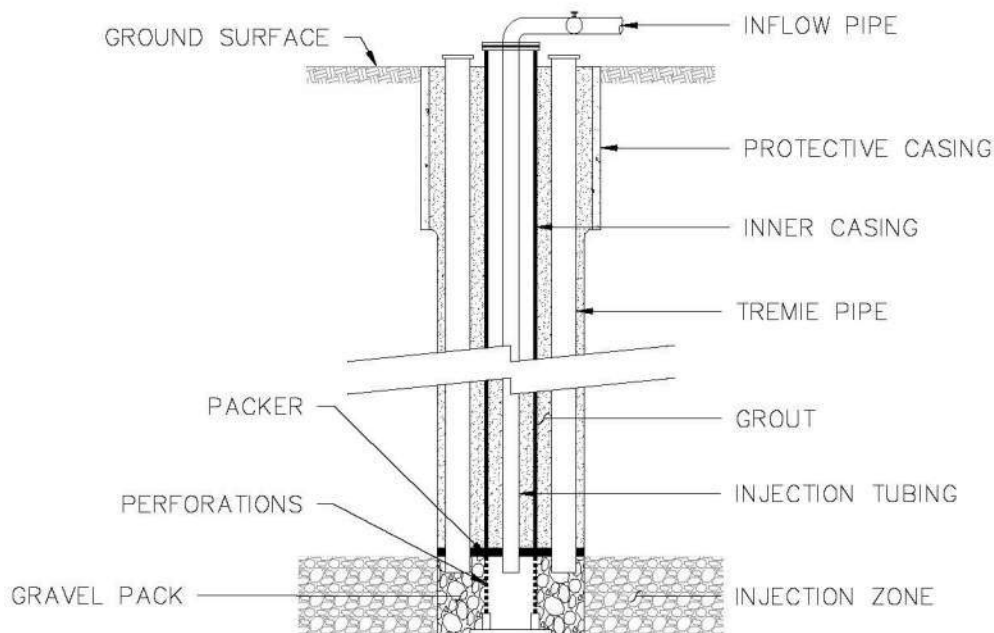

**Figure 10-4 Injection Well Design**

### 10.3.2 Site Requirements and Existing Constraints

The location of the injection well(s) must be in proximity to the diversions, such that flows for recharge can be conveyed to the site. The site must also be able to accommodate the necessary treatment, which will depend on the aquifer characteristics. Treatment could be up to drinking water standards under the worse-case scenario. Site requirements described in **Section 10.2.2** regarding a treatment system would also apply under this alternative. Potential sites will require a hydrogeologic evaluation to identify the aquifer depth and characteristics, hydraulic characteristics, local groundwater flow gradient, nearby drinking wells, and more. The injection well(s) should not be located in close proximity to other drinking water wells.

A wellhouse is used to house the wellhead facilities, which extend out of the ground. In some instances, the wellhead could be located within a vault. The wellhead will include valves and flow meters to monitor how much water is injected and regulate flow for injection. Monitoring wells may need to be located in close proximity to the injection well, as they will be used to monitor the well characteristics and performance and collect samples as needed.

A centralized location would be ideal if an advanced treatment system is needed, as it would be more economical to design and construct one treatment facility as opposed to three. This would also allow for more centralized maintenance to occur. If advanced treatment greater than that described under Treatment Alternative T1 is not needed, then it may be more beneficial to have decentralized injection wells, each located in close proximity to the diversion sites, if conditions allow for it. This would reduce the amount of piping necessary for the centralized system.

### 10.3.3 Operation and Maintenance

The treatment process required prior to injection will require O&M, similar to that described under Treatment Alternative T2. The treatment components will require regular inspection and periodic maintenance, such that the system functions as intended and meets the water quality requirements prior to injecting. The pump used to inject flows will require maintenance, similar to that summarized in **Section 7**.

The injection well itself will also require maintenance. A properly designed pretreatment unit will limit the accumulation of sediment within the inner casing. However, unless additional treatment is implemented, sediment is still likely to build up over time. Determining how often the inner casing will need to be cleaned out will require monitoring of the well throughout its first few years of service. Periodic backflushing will be required to clean the well head and screen. During the backwash process, the well will switch from injection mode to production mode and the change in flow direction allows for the removal of softer materials. Backwash material is typically discharged to the sanitary sewer or back to the treatment process. Wellhead maintenance and rehabilitation will be necessary over time. It is recommended to wait until problems are observed, as these treatments are more costly. Typical rehabilitation periods range from five to ten years. Chemical treatments may be needed periodically to further improve efficiency. Sometimes chlorinated water is used to control bacterial activity adjacent to the well.

It is recommended that the Cities determine who will be responsible for maintenance prior to final design, such that those maintaining the system can provide input as to any manufacturer/part preferences and available equipment for maintenance. This may not be as critical if a third party will be hired to perform

maintenance. O&M of the diversion, pump, sewer connection, and other appurtenances are described in **Section 7**.

The following general O&M can be expected at a treatment facility related to the selected equipment, along with the injection well:

- Component inspection and servicing
- System cleaning
- Valve inspection and maintenance (periodic replacement)
- Periodic backwashing of well screen
- Chemical treatment of treatment system and injection system

### 10.3.4 Similar Projects and Probable Cost

Probable costs to implement Treatment Alternative T3 will vary depending on several factors, including whether a centralized or decentralized system is selected, water quality, hydrogeology of injection site(s), treatment requirements and approach, packaged versus designed system, and land acquisitions, among other factors. **Table 10-6** summarizes implementation efforts using a similar approach within Los Angeles County. The table identifies the similar project, year it was constructed, capacity, and cost. **Section 6** identifies the anticipated capacity of each site depending on whether storage is used or not. The capacity of each system individually varies from 630 to 1,436 gpm (0.9 to 2.0 Million Gallons per Day [MGD]), with a cumulative capacity ranging from 2,430 to 3,600 gpm (3.5 to 5.2 MGD).

**Table 10-6 Similar Projects to Treatment Alternative T3**

Project	Size	Year	Cost	Notes
Goldsworthy Desalter Expansion	2.5 MGD	2019	\$22,400,000	Torrance and WRD expand facility, including two new wells and RO treatment, providing additional 2.5 MGD
LACPW Alamitos Barrier Project	5.4 MGD	2012	\$1,500,000	Partnered with Orange County and included 43 injection wells (does not include treatment costs – purchases water to inject)
LACPW Dominguez Gap Barrier	1 MGD	2014	\$1,900,000	41 injection wells (does not include treatment costs – purchases water to inject)

### 10.3.5 Permitting

Similar to the alternatives discussed in **Section 4**, Treatment Alternative T3 will be subject to most of the permits/approvals described in **Section 9**, potentially including land acquisition. Additionally, improvements will be subject to the USEPA's Underground Injection Control (UIC) program described below. This alternative may also be subject to a Caltrans encroachment permit, as described in **Section 10.2.5.2**, depending on the alignment of piping, specifically if a centralized approach is implemented. Other regulatory permits may be required depending on the treatment standard necessary.



**10.3.5.1 USEPA Underground Injection Control Program**

The injection well proposed under Treatment Alternative T3 is classified as a Type V well under USEPA’s UIC program. As such, injected flows must be consistent with the regulations set forth by CFR Title 40 which states:

*"If you own or operate any type of Class V well, the regulations below require that you cannot allow movement of fluid into underground sources of drinking water (USDWs) that might cause endangerment, you must comply with other Federal UIC requirements in 40 CFR parts 144 through 147, and you must comply with any other measures required by your State or EPA Regional Office UIC Program to protect USDWs, and you must properly close your well when you are through using it."*

In addition to inhibiting the endangerment of USDW, basic inventory information must be submitted for the injection well, per 40 CFR 144.26. The following information must be submitted:

- Facility name and location,
- Name and address of legal contact,
- Ownership of facility,
- Nature and type of injection wells, and
- Operating status of injection wells.

This information can be provided in the UIC summary reporting forms which must be submitted prior to injection. These forms are provided in **Appendix T**.

**10.3.6 Pros and Cons**

**Table 10-7** below summarizes the pros and cons associated with Treatment Alternative T3. **Table 10-8** summarizes the pros and cons of selecting a centralized system over a decentralized system.

**Table 10-7 Pros and Cons for Treatment Alternative T3**

Pros	Cons
<ul style="list-style-type: none"> <li>➤ Provides groundwater recharge (water conservation benefit)</li> <li>➤ LACSD and Watermaster fees would not apply</li> </ul>	<ul style="list-style-type: none"> <li>➤ Requires several miles of force main for centralized system</li> <li>➤ Advanced treatment may be necessary (depending on aquifer characteristics)</li> <li>➤ Much higher upfront capital cost as compared to LRS approach</li> <li>➤ Stringent sampling regulations</li> <li>➤ Prevents water from reaching natural channel portions downstream of Project on Rio Hondo</li> <li>➤ Specialized maintenance for treatment system and injection well</li> </ul>



**Table 10-8 Pros and Cons for Treatment Alternative T3 – Centralized**

Pros	Cons
<ul style="list-style-type: none"> <li>➤ Only one treatment system required</li> <li>➤ O&amp;M at one location</li> <li>➤ Less expensive</li> <li>➤ Single acquisition/property needed</li> </ul>	<ul style="list-style-type: none"> <li>➤ Excessive piping required from diversion sites to treatment facility (pipe O&amp;M distributed across several jurisdictions)</li> <li>➤ Large pumps required to deliver flows to recycled water system due to headlosses</li> </ul>

### 10.3.7 Next Steps

If the Treatment Alternative T3 approach is of interest to the Cities, the following steps would be necessary to further assess feasibility and cost:

1. Hydrogeologic evaluation required
  - a. Assess aquifer characteristics (depth, type, layers, etc.)
  - b. Determine aquifer flow direction
  - c. Identify any nearby injection wells
  - d. Perform pump or slug test
  - e. Observation wells to observe lateral spread and mounding
  - f. Groundwater modeling (depending on location, depth to potable water aquifer, etc.)
2. Further evaluation to determine if a single centrally located treatment facility is preferred over multiple facilities (review of potential sites).
3. Coordination with LARWQCB to confirm deviation from LRS approach.

# 11. Summary and Recommendations

**Table 11-1** summarizes the current design recommendations for the Project based on the analyses and assessments included in this study. Details and discussions surrounding the identified elements are found in the sections above. These recommendations will evolve through the design process. Preliminary concept drawings are included in **Appendix U**.

The costs (capital and O&M) are lower for the LRS approach as compared to the treatment alternatives, especially in the short term. The Cities are required to comply with several wet-weather TMDLs within these same watersheds (Alhambra, Eaton, and Rubio Washes) and implementation efforts are anticipated upstream. Wet-weather projects will ultimately address most of the dry-weather runoff. It is therefore anticipated that these washes will convey less dry-weather runoff in the future once wet-weather projects and programs are implemented upstream. For this reason, the efforts made now may not be as critical in the long-term, making upfront investments not as economical (such as treatment facilities).

Varying approaches can be implemented at each wash. As an example, a site with lower flows may be diverted to the sanitary sewer, while larger flows could be treated and released downstream for beneficial uses. It should be noted that the compliance for treated and released water will only be at the point of discharge and not downstream. The implementing agencies agreed that the same approach should be used at all three sites, as recommended below.

**Table 11-1 Project Recommendations**

Element	Recommendation
Project type/approach	Divert dry-weather flows for UV treatment and discharge back to wash (Treatment Alternative T1)
Diversion system	Rubber dam diversion (Diversion Alternative 3) to accomplish flow capture and provide in-line storage for equalization before treatment (rubber dam height will be less than that described for the sewer diversion approach)
Pump	Submersible diversion pump required downstream of diversion before treatment to lift flows from channel (gravity flow through treatment)
Storage	Rubber dam diversion to provide in-line storage
Data needs for final design	The following information is pertinent to final design: <ul style="list-style-type: none"> <li>➤ UV transmittance and TSS monitoring will be required at each wash to design UV treatment system and pretreatment</li> <li>➤ Maintenance agency will need to be determined and will influence component selection</li> <li>➤ Existing structural design/calculations for channel infrastructure would be beneficial in redesign of channel structure</li> <li>➤ More recent flow quantification would allow for Project optimization</li> <li>➤ Coordination for use or purchase of private property will be necessary for Alhambra Wash and Rubio Wash</li> </ul>



The approaches presented in this study were taken into consideration by the implementing agencies before identifying the recommendations above. The following factors played a role in selecting the treat and release approach (Treatment Alternative T1):

- Maintaining water source in downstream natural area to preserve habitat
- Understanding upstream improvements to address wet-weather flows will minimize dry-weather flow rates in the future
- Lower short- and long-term capital and O&M costs

## 11.1 Cost Opinion

Preliminary cost opinions were developed for Alhambra, Eaton, and Rubio Washes based on the recommended approach (UV treatment based on Treatment Alternative T1). **Table 11-2**, **Table 11-3**, and **Table 11-4** summarize the cost opinions for Alhambra, Eaton, and Rubio Washes, respectively. The cost opinions were developed using various sources of information as well as the engineer's best judgement. A contingency of 30 percent is included due to the preliminary nature of the opinion and will be decreased in design level opinions. It should be noted that sewer connections will be required for byproducts from pretreatment process, requiring additional coordination with LACSD during the final design phase. Some of the individual line item costs/unit prices identified in the following tables do not match the those included in **Section 8**. This is based on advancement in design and refined sizes/layouts. The cost opinions do not include costs associated with land acquisition, as discussed in **Section 9.9**, which may apply to Alhambra Wash and Rubio Wash.

**Table 11-2 Opinion of Probable Cost for Alhambra Wash Recommended Alternative**

Item No.	Description	Unit	Quantity	Unit Price	Total
1	Mobilization (10%)	LS	1	\$192,500	\$192,500
2	Site Demolition	LS	1	\$60,000	\$60,000
3	Diversion Structure (Rubber Dam)	LS	1	\$650,000	\$650,000
4	Diversion Pipe (24" RCP)	LF	40	\$350	\$14,000
5	Pretreatment System	LS	1	\$142,500	\$142,500
6	Pump	LS	1	\$351,000	\$351,000
7	Discharge Pipe (Channel)	LF	40	\$100	\$4,000
8	Discharge Pipe/Sewer Connection	LS	1	\$68,500	\$68,500
9	UV Treatment System	LS	1	\$385,000	\$385,000
10	SCADA and Electrical Appurtenances	LS	1	\$250,000	\$250,000
Total					\$2,117,500
30% Contingency					\$635,300
<b>Grand Total</b>					<b>\$2,752,800</b>

**Table 11-3 Opinion of Probable Cost for Eaton Wash Recommended Alternative**

Item No.	Description	Unit	Quantity	Unit Price	Total
1	Mobilization (10%)	LS	1	\$172,700	\$172,700
2	Site Demolition	LS	1	\$60,000	\$60,000
3	Diversion Structure (Rubber Dam)	LS	1	\$650,000	\$650,000
4	Diversion Pipe (24" RCP)	LF	50	\$350	\$17,500
5	Pretreatment System	LS	1	\$142,500	\$142,500
6	Pump	LS	1	\$282,000	\$282,000
7	Discharge Pipe (Channel)	LF	30	\$100	\$3,000
8	Discharge Pipe/Sewer Connection	LS	1	\$11,600	\$11,600
9	UV Treatment System	LS	1	\$310,000	\$310,000
10	SCADA and Electrical Appurtenances	LS	1	\$250,000	\$250,000
Total					\$1,899,300
30% Contingency					\$569,800
<b>Grand Total</b>					<b>\$2,469,100</b>

**Table 11-4 Opinion of Probable Cost for Rubio Wash Recommended Alternative**

Item No.	Description	Unit	Quantity	Unit Price	Total
1	Mobilization (10%)	LS	1	\$169,100	\$169,100
2	Site Demolition	LS	1	\$60,000	\$60,000
3	Diversion Structure (Rubber Dam)	LS	1	\$650,000	\$650,000
4	Diversion Pipe (24" RCP)	LF	40	\$350	\$14,000
5	Pretreatment System	LS	1	\$142,500	\$142,500
6	Pump	LS	1	\$326,000	\$326,000
7	Discharge Pipe (Channel)	LF	30	\$100	\$3,000
8	Discharge Pipe/Sewer Connection	LS	1	\$23,300	\$23,300
9	UV Treatment System	LS	1	\$372,000	\$372,000
10	SCADA and Electrical Appurtenances	LS	1	\$250,000	\$250,000
Total					\$1,859,900
30% Contingency					\$558,000
<b>Grand Total</b>					<b>\$2,417,900</b>

**Table 11-5** summarizes overall implementation costs by location and total, which will be used to support funding requests. Administrative costs are not currently accounted for separately. Construction costs are based on the cost opinion and other implementation line items are based on the percentage indicated (percent of construction cost).

**Table 11-5 Summary of Implementation Costs**

Description	Alhambra Wash	Eaton Wash	Rubio Wash	Total
Planning	\$125,000	\$125,000	\$125,000	<b>\$375,000</b>
Design (10%)	\$275,300	\$247,000	\$241,800	<b>\$764,100</b>
Environmental/Permitting (10%)	\$275,300	\$247,000	\$241,800	<b>\$764,100</b>
Construction Administration (15%)	\$413,000	\$370,400	\$362,700	<b>\$1,146,100</b>
Construction (Opinion Above)	\$2,752,00	\$2,469,100	\$2,417,900	<b>\$7,639,800</b>
<b>Total</b>	<b>\$3,841,400</b>	<b>\$3,458,500</b>	<b>\$3,389,200</b>	<b>\$10,689,100</b>



## 12. References

- California Department of Fish and Wildlife (CDFW). 2008. LSA Notification Forms, Instructions, and Fees. Printable version of Questions and Answers. <https://nrm.dfg.ca.gov/FileHandler.ashx?DocumentID=3771&inline>. Accessed March 21, 2019.
- CWE. 2019. Water Quality Monitoring Results for RH3\_ARC as part of the Rio Hondo/San Gabriel River Water Quality Group Coordinated Integrated Monitoring Program Implementation. Results from Dry-Weather Events between January 2016 and December 2018.
- Los Angeles County Department of Public Works (LACPW). 2014. West Coast Basin Barrier Project Unit 12 Injection and Observation Wells. As-Builts. PD052925.
- Los Angeles County Department of Public Works (LACPW). 2016-2017. Alamos Barrier Project. Prepared by Aric Rodriguez and Jason St. Pierre. [https://dpw.lacounty.gov/wrd/barriers/files/ABP\\_FY16-17\\_Annual\\_JMC\\_Report.pdf](https://dpw.lacounty.gov/wrd/barriers/files/ABP_FY16-17_Annual_JMC_Report.pdf).
- Los Angeles County Department of Public Works (LACPW). 2019. Water Quality Results for RH\_SLA as part of the Upper Los Angeles River Coordinated Integrated Monitoring Program Implementation. Data emailed by Joseph Venzon to Katie Harrel on May 2, 2019.
- Los Angeles County Flood Control District (LACFCD). March 1936 (Latest Revision). Rubio Wash As-Builts. January 1935. PD002275.
- Los Angeles County Flood Control District (LACFCD). October 1961 (Latest Revision). Eaton Wash As-Builts. November 20, 1936. Drawing No. 24-D13, PD003809.
- Los Angeles County Flood Control District (LACFCD). December 1985 (Latest Revision). Project No. 5, Alhambra-Monterey Park, Line B As-Builts. Prepared by William J. Fox. June 23, 1954. Drawing No. 81-5-D1, PD023588.
- Los Angeles County Flood Control District (LACFCD). 2018. Flow Data for Stations F81D, F318, and F82C emailed by Arthur Gotingco to Katie Harrel on November 29, 2018.
- Los Angeles County GIS Data Portal. 2018. <https://egis3.lacounty.gov/dataportal/>.
- Los Angeles County Sanitation Districts (LACSD). August 6, 2012. Guidelines for the Discharge of Rainwater, Stormwater, Groundwater and Other Water Discharges. [https://lacs.org/wastewater/industrial\\_waste/iwpolicies/waterdischarges.asp](https://lacs.org/wastewater/industrial_waste/iwpolicies/waterdischarges.asp). Accessed February 28, 2019.
- Los Angeles County Sanitation Districts (LACSD). 2014. Dry weather Urban Runoff Policy. <https://www.lacs.org/civicax/filebank/blobdload.aspx?blobid=2560>. Accessed February 28, 2019.
- Los Angeles Regional Water Quality Control Board (LARWQCB). 2010. Amendment to the Water Quality Control Plan for the Los Angeles Region to Incorporate a Total Maximum Daily Load for Indicator Bacteria in the Los Angeles River Watershed. Resolution No. R10-007. July 9, 2010.

Los Angeles Regional Water Quality Control Board (LARWQCB). 2012. NPDES Waste Discharge Requirements for Municipal Separate Storm Sewer System (MS4) Discharges within the Coastal Watersheds of Los Angeles County, Except Those Discharges Originating from the City of Long Beach. NPDES Permit No. CAS004001; Order No. R4-2012-0175.

Los Angeles Regional Water Quality Control Board (LARWQCB). 2018. Order No. R4-2018-0125, General NPDES Permit No. CAG994004, Waste Discharge Requirements for Discharges of Groundwater from Construction and Project Dewatering to Surface Waters in Coastal Watersheds of Los Angeles and Ventura Counties. Effective Date: November 13, 2018.

Los Angeles Regional Water Quality Control Board (LARWQCB). 2019. 401 Water Quality Certification and Waste Discharge Requirements Program. [https://www.waterboards.ca.gov/losangeles/water\\_issues/programs/401\\_water\\_quality\\_certification/](https://www.waterboards.ca.gov/losangeles/water_issues/programs/401_water_quality_certification/). Accessed on April 24, 2019.

Metropolitan Water District (MWD). Regional Recycled Water Advanced Purification Center. [http://www.mwdh2o.com/PDF About Your Water/Regional Recycled Water Supply Program.pdf](http://www.mwdh2o.com/PDF%20About%20Your%20Water/Regional%20Recycled%20Water%20Supply%20Program.pdf). Accessed January 2020.

Oram, Brian. Water Research Center. Ozonation in Water Treatment. Accessed January 2020. <http://www.water-research.net/index.php/ozonation>.

Purifics. 2019a. CUF (Ceramic Ultra Filtration). <http://www.purifics.com/complete-ultra-filtration-cuf>. Accessed November 8, 2019.

Purifics. 2019b. <http://www.purifics.com/water-treatment-capabilities>. Accessed November 8, 2019.

Purifics. 2019c. <http://www.purifics.com/photo-cat-photocatalytic-membrane-system>. Accessed November 8, 2019.

State of California. October 2015. Senate Bill No. 485. Chapter 678, an act to add Section 4730.68 to the Health and Safety Code. [https://leginfo.ca.gov/faces/billNavClient.xhtml?bill\\_id=201520160SB485](https://leginfo.ca.gov/faces/billNavClient.xhtml?bill_id=201520160SB485).

State Water Resources Control Board (SWRCB). October 2018. Regulations Related to Recycled Water. Includes Title 17 and 22 Code of Regulations.

United States Army Corps of Engineers (USACE). July 1937. Alhambra Wash Improvement Record Drawings.

United States Army Corps of Engineers (USACE). 2017. 2017 Nationwide Permits, General Conditions, District Engineer's Decision, Further Information, and Definitions. <https://usace.contentdm.oclc.org/utills/getfile/collection/p16021coll7/id/8593>. Accessed February 28, 2019.

United States Army Corps of Engineers (USACE). September 7, 2018 (2018). Section 408 Process. <https://www.usace.army.mil/Media/Fact-Sheets/Fact-Sheet-Article-View/Article/1623978/section-408-process/>. Accessed March 21, 2019.



United States Environmental Protection Agency (USEPA). Basic Information on Section 401 Certification. <https://www.epa.gov/cwa-401/basic-information-section-401-certification>. Accessed April 23, 2019.

United States Environmental Protection Agency (USEPA). 1999. The Class V Underground Injection Control Study. Volume 1: Study Approach and Findings and Volume 21: Aquifer Recharge and Aquifer Storage and Recovery Wells. <https://www.epa.gov/uic/class-v-underground-injection-control-study>. Accessed January 2020.

United States Environmental Protection Agency (USEPA). January 2013. Design and Installation of Monitoring Wells. [https://www.epa.gov/sites/production/files/2016-01/documents/design\\_and\\_installation\\_of\\_monitoring\\_wells.pdf](https://www.epa.gov/sites/production/files/2016-01/documents/design_and_installation_of_monitoring_wells.pdf). Accessed January 2020.

United States Environmental Protection Agency (USEPA). 2013. Water: Discharge of Dredged Fill Materials (404). Section 404 Permitting. <http://water.epa.gov/lawsregs/guidance/cwa/dredgdis/>. Accessed March 31, 2019.

Upper Los Angeles River Watershed Management Group. 2016. Enhanced Watershed Management Program (EWMP) for the Upper Los Angeles River Watershed.

Upper Los Angeles River Watershed Management Group, Los Angeles River Upper Reach 2 Group, Lower Los Angeles River Watershed Management Program Group, City of El Monte, and City of Irwindale. March 2016. Rio Hondo Load Reduction Strategy for Los Angeles River Watershed Bacteria TMDL. Prepared by Paradigm Environmental, Larry Walker and Associates, and CDM Smith.

Upper Los Angeles River Watershed Management Program Group. September 2017. Rio Hondo Load Reduction Strategy: Addendum to Revise Implementation Actions for Alhambra Wash, Eaton Wash, and Rubio Wash. Revision to the March 2016 Rio Hondo Load Reduction Strategy.

Water Research Foundation (WRF). 2008. Design, Operation, and Maintenance for Sustainable Underground Storage Facilities. Prepared by Herman Bouwer, R. David G. Pyne, Jess Brown, Daniel St Germain, Tom M. Morris, Christopher J. Brown, Peter Dillon, and Mitchell J. Rycus. Published by American Water Works Association (AWWA).

West Basin Municipal Water District. 2020. Proposition 84, Round 3: Goldsworthy Desalter Expansion Project.. <https://www.westbasin.org/policy-planning-integrated-planning/proposition-84-round-3>. Accessed January 2020.

West Basin Municipal Water District. 2020. Seawater Barriers. <https://www.westbasin.org/water-supplies-groundwater/seawater-barriers/>. Accessed January 2020.

# Appendix A

## Topographic Surveys



# Appendix B

## Geotechnical Report



# Appendix C

## Utility Log



# Appendix D

## Proposed Improvements



# Appendix E

## Diversion Alternatives



# Appendix F

## Dry-Weather Flow Field Investigation



# **Appendix G**

## **Flow Analysis**





## Average Dry-Weather Discharge Flow Rates

The average Discharge flow rates for each wash were calculated by each season within each year, defined according to the following list:

- Winter: December through February
- Spring: March through May
- Summer: June through August
- Fall: September through November

The average dry-weather flow rate in each season is shown in **Figure G-1**. No maximum caps were applied to the data presented in this section; therefore, the assessment includes dry-weather flows with large peaks that are likely not associated with typical dry-weather runoff. Prior to 2015, the average Discharge flow rate for Alhambra Wash typically exceeded Eaton and Rubio Washes; however, since 2015, the Alhambra Wash flow rate has decreased and the Eaton Wash flow rate has increased. The average seasonal Discharge flow rates showed greater variation prior to 2008 for all three washes, with the average flow rates lower and with less variation since 2008. The seasonal average day (8 am to 10 pm) and night (10 pm to 8 am) Discharge flow rates from 2008 to 2018 for the three washes are shown in **Figure G-2**. The average daytime flow rates were typically greater than the nighttime flow rates. The average daytime and nighttime Discharge flow rates were lower than the LRS flow rate (2.23 cfs) from 2013 to 2018 in Alhambra Wash. The average day and night Discharge flow rates in Eaton Wash were similar to the LRS flow rate (1.40 cfs) from 2017 to 2018. The average day and night Discharge flow rates were lower than the LRS flow rate (1.78 cfs) from 2009 to 2018 in Rubio Wash. The data presented in the two figures below extends to 2018 (past the analysis limits) to provide context to more recent conditions.

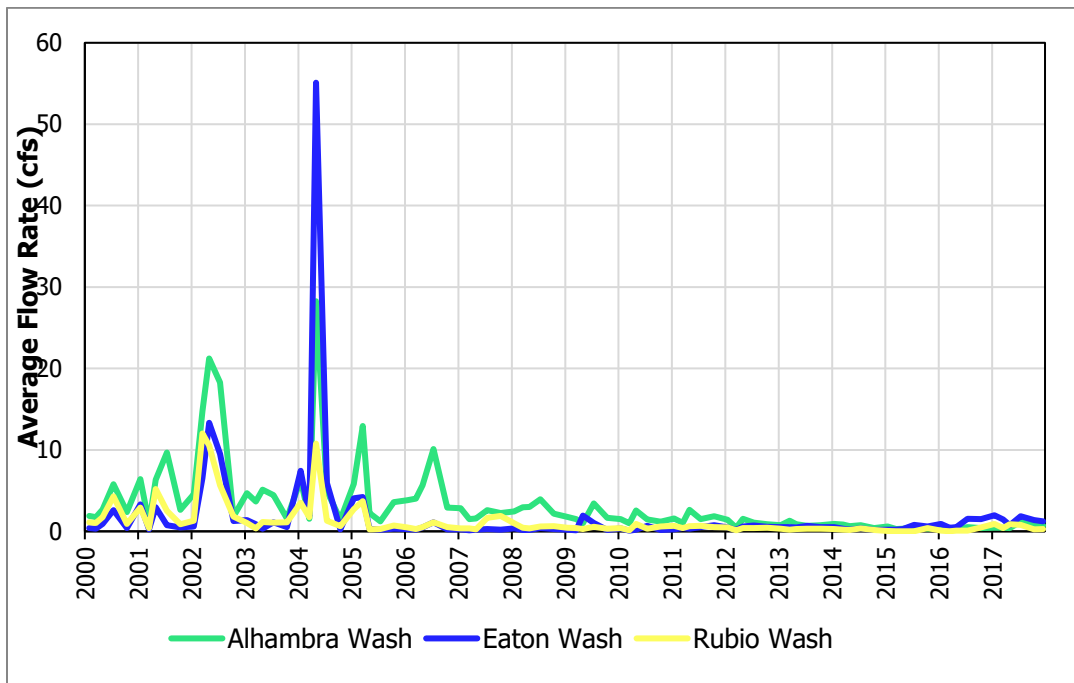

**Figure G-1 Average Seasonal Dry-Weather Discharge Flow Rates**

When the peaks observed in the figure above are consistent for all three washes, it is assumed there was rain somewhere within the tributary watersheds, even if rain was not recorded at the local rain gage used to remove wet-weather flow days.

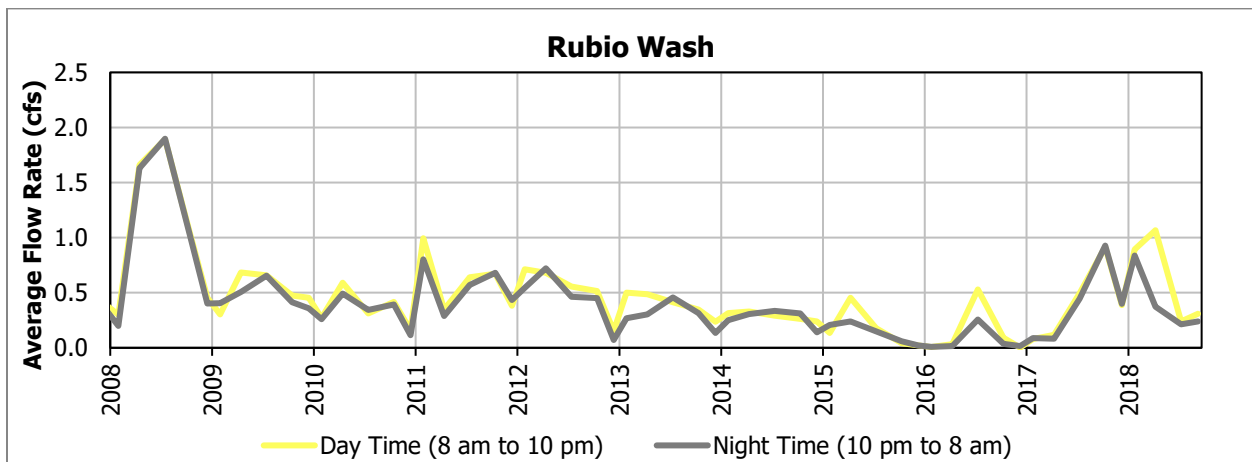
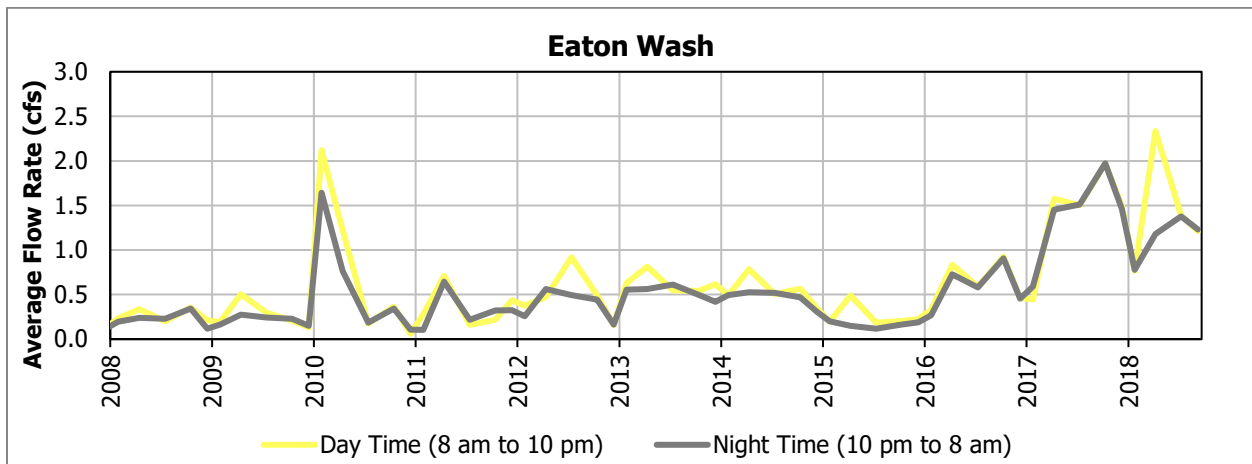
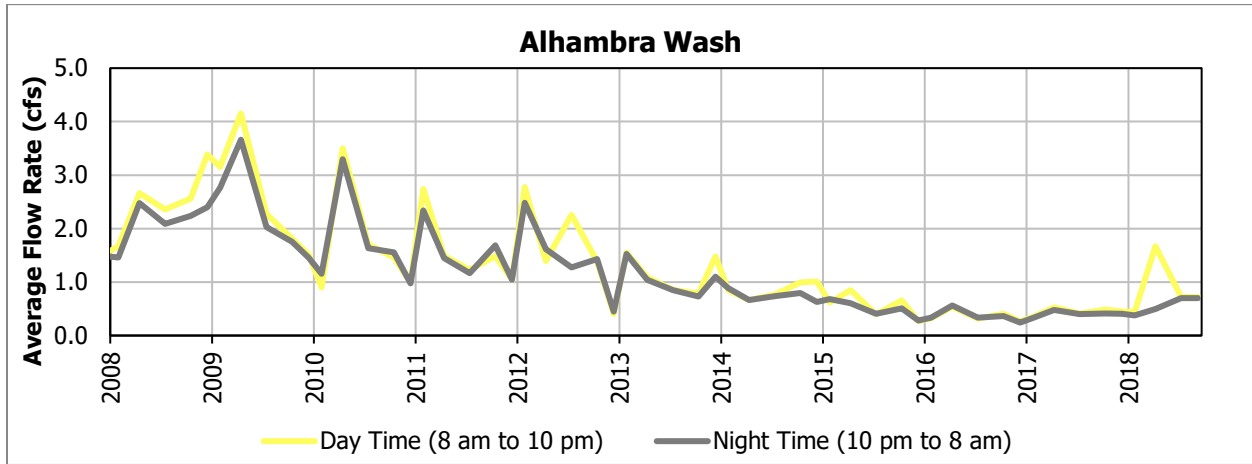

**Figure G-2 Average Dry-Weather Day and Night Flow Rates**



# Appendix H

## Main San Gabriel Basin Watermaster Letter



# Appendix I

## Section 408 Related Documents



# Appendix J

## CWA 404 Certification Related Documents



# Appendix K

## Fish and Wildlife Code 1600 Related Documents



# Appendix L

## CWA 401 Certification Related Documents



**Appendix M**  
**General NPDES Permit No. CAG994004**  
**Related Documents**





# Appendix N

## DSA Related Documents



# Appendix O

## LACFCD Connection Permit Related Documents



# Appendix P

## LACSD Connection Permit Related Documents



# Appendix Q

## Right-of-Way Valuation Service



**Appendix R**

**LADPH Cross Connection and Water Pollution  
Control Program Documents**



## Appendix S

# Caltrans Encroachment Permit Documents

Reference documents attached to PDF (click paperclip to access documents)



# Appendix T

## UIC Reporting Forms



# Appendix U

## Preliminary Plans for Recommended Design





# Geotechnical Engineering Report

SGVCOG ACE Rio Hondo Load Reduction Strategy Design Project

San Gabriel Valley  
Los Angeles County, California

March 6, 2019

Terracon Project No. 60185184

**Prepared for:**  
CWE Corporation  
Fullerton, California

**Prepared by:**  
Terracon Consultants, Inc.  
Tustin, California

[terracon.com](http://terracon.com)

**Terracon**

Environmental



Facilities



Geotechnical



Materials



March 6, 2019

CWE Corporation  
1561 E. Orangethorpe Avenue, Suite 240  
Fullerton, CA 92831

Attn: Mr. Vik Bapna, P.E.  
Principal  
P: 714-526-7500 ext.212  
E: vbapna@cwecorp.com

Re: **Geotechnical Engineering Report**  
**SGVCOG ACE Rio Hondo Load Reduction Strategy Design Project**  
**San Gabriel Valley**  
**Los Angeles County, California**  
**Terracon Project No. 60185184**

Dear Mr. Bapna:

Terracon has completed geotechnical engineering exploration for the proposed underground infiltration systems and stormwater structures planned at Alhambra Wash, Rubio Wash and Eaton Wash which are located within San Gabriel Valley in Los Angeles County, California. The purpose of this study was to evaluate the pertinent geotechnical conditions at the site and to develop geotechnical parameters which will assist in the design and construction of the planned underground infiltration systems onsite.

We appreciate the opportunity to be of service to you on this project. If you have any questions concerning this report, or if we may be of further service, please contact us.

Sincerely,  
**Terracon Consultants, Inc.**

  
Sivasubramaniam (Raj) Pirathiviraj, P.E.,  
Senior Engineer

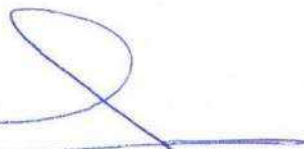

  
Fred Buhamdan, P.E.  
Principal



Terracon Consultants, Inc. 1421 Edinger Avenue, Suite C Tustin, California 92780  
P [949] 261 0051 F [949] 261 6110 terracon.com

**TABLE OF CONTENTS**

<b>1.0</b>	<b>INTRODUCTION</b> .....	<b>2</b>
<b>2.0</b>	<b>PROJECT INFORMATION</b> .....	<b>3</b>
<b>3.0</b>	<b>SUBSURFACE CONDITIONS</b> .....	<b>3</b>
3.1	Field Exploration .....	3
3.2	Typical Subsurface Profile .....	4
3.3	Groundwater .....	5
3.4	Seismic Considerations.....	6
3.4.1	Seismic Site Classification Parameters.....	6
3.4.2	Faulting and Estimated Ground Motions.....	6
3.4.3	Liquefaction .....	7
3.5	Percolation Test Results .....	8
3.6	Corrosion Potential .....	10
<b>4.0</b>	<b>RECOMMENDATIONS FOR DESIGN AND CONSTRUCTION</b> .....	<b>11</b>
4.1	Pump Station Structure Foundation .....	11
4.2	Lateral Earth Pressure .....	12
4.2.1	Cantilevered Shoring Recommendations.....	12
4.2.2	Braced Shoring Recommendations .....	12
4.3	Pavements.....	13
4.3.1	Design Recommendations.....	13
4.3.2	Construction Considerations.....	14
4.4	Earthwork .....	15
4.4.1	Excavations .....	16
4.4.2	Open Trench Construction.....	17
4.4.3	Below Grade Structures Considerations .....	18
4.4.4	Utility Trenches.....	19
<b>5.0</b>	<b>GENERAL COMMENTS</b> .....	<b>20</b>

**Geotechnical Engineering Report**

SGVCOG ACE Rio Hondo Load Reduction Strategy Design Project  
San Gabriel Valley, CA ■ March 6, 2019 ■ Terracon Project No. 60185184



**Table of Contents (continue)**

**APPENDIX A – FIELD EXPLORATION**

Exhibit A-1	Site Location Plan
Exhibit A-2A to A-2C	Boring Location Diagram
Exhibits A-3 to A-13	Boring Logs

**APPENDIX B – LABORATORY TESTING**

Exhibit B-1	Atterberg Limits Results
Exhibit B-2	Direct Shear Test
Exhibit B-3	Corrosion Test Results

**APPENDIX C – SUPPORTING DOCUMENTS**

Exhibit C-1	General Notes
Exhibit C-2	Unified Soil Classification

**APPENDIX D – LIQUEFACTION ANALYSIS**

**GEOTECHNICAL ENGINEERING REPORT**  
**SGVCOG ACE RIO HONDO LOAD REDUCTION STRATEGY DESIGN PROJECT**  
**SAN GABRIEL VALLEY, LOS ANGELES COUNTY, CALIFORNIA**

Terracon Project No. 60185184

March 6, 2019

**1.0 INTRODUCTION**

This report presents the results of our geotechnical engineering services performed for the proposed underground infiltration systems and stormwater structures planned at the following facilities located within San Gabriel Valley in Los Angeles County, California.

- Alhambra Wash
- Rubio Wash
- Eaton Wash

The Site Location Plan (Exhibit A-1) is included in Appendix A of this report. The purpose of these services is to provide information and geotechnical engineering recommendations relative to:

- subsurface soil conditions
- groundwater conditions
- earthwork
- lateral earth pressures for shoring
- percolation rates
- liquefaction analysis
- pavement design

Our geotechnical scope of work included the advancement of eleven (11) test borings as follows:

Sub-Project	Boring	Type of Boring	Boring Depth (feet)
Alhambra Wash	BA-1	Hollow-Stem Auger Boring	51.5
	BA-2	Hollow-Stem Auger Boring	26.5
	BA-3	Hollow-Stem Auger Boring	10.0
	BA-4	Hollow-Stem Auger Boring	10.0
	PA-1	Percolation Boring	25.0
Eaton Wash	BE-1	Hollow-Stem Auger Boring	51.5
	BE-2	Hollow-Stem Auger Boring	26.5
	PE-1	Percolation Boring	25.0
Rubio Wash	BR-1	Hollow-Stem Auger Boring	51.5
	BR-2	Hollow-Stem Auger Boring	26.5
	PR-1	Percolation Boring	25.0

Logs of the borings along with a Boring Location Diagram (Exhibit A-2A to A-2C) are included in Appendix A of this report. The results of the laboratory testing performed on soil samples obtained from the site during the field exploration are included in Appendix B of this report.

## 2.0 PROJECT INFORMATION

ITEM	DESCRIPTION
<b>Proposed Systems</b>	<p>The project will include three (3) stormwater Low Flow Diversion (LFD) systems at the three facilities (1 each). Each system will include piping, wet well pump intake, pump station, and infiltration systems with a bottom at 23 feet below existing ground surface. The pump station is proposed to be installed inside underground vault structures and bottom of the vault structure is at approximate depth of 18 feet bgs.</p> <p>The Alhambra Wash site will include additional piping within the adjacent Rush Street.</p>
<b>Location</b>	<p>This study includes 3 facilities along existing washes within the San Gabriel valley in Los Angeles County, California.</p> <ul style="list-style-type: none"> <li>■ Alhambra Wash Site – located on the south side of Rush Street, approximately 400 feet west of S. Walnut Grove Avenue in South San Gabriel, CA</li> <li>■ Eaton Wash Site – located on the southwest side of an existing mobile home park approximately 500 feet west of Baldwin Avenue and 400 feet south of Loftus Drive, in Rosemead, CA</li> <li>■ Rubio Wash Site – located on the southwest side of Rosemead Boulevard approximately 900 feet northwest of Garvey Avenue in Rosemead, CA</li> </ul>
<b>Existing site features</b>	<p>The project sites are existing washes that are comprised of 40 to 60-foot wide, 8 to 16-foot deep depressed channels bounded by concrete retaining walls.</p>
<b>Existing Topography</b>	<p>Surrounding developments of the washes are relatively flat.</p>
<b>Current ground cover</b>	<p>The ground within the banks of the channels and areas of exploration is currently unpaved. Rush Street is covered with asphalt concrete pavement.</p>

## 3.0 SUBSURFACE CONDITIONS

### 3.1 Field Exploration

The scope of the services performed for this project included site reconnaissance by a field representative, subsurface exploration program, laboratory testing, and engineering analyses for the proposed improvement. Total of eight (8) borings and three (3) percolation tests were performed on site as shown on Exhibits A-2A through A-2C in Site Location. The borings were marked on-site using the site plan, aerial photograph, and a handheld GPS device. The accuracy of the boring locations should only be assumed to the level implied by the method used.

Continuous lithologic logs of the test borings were recorded by our field representative during the drilling operations. At selected intervals, samples of subsurface materials were taken by driving split-spoon or ring-lined barrel samplers. Groundwater conditions were evaluated in the borings at the time of site exploration.

Penetration resistance measurements were obtained by driving the split-spoon and ring-barrel samplers into the subsurface materials with a 140-pound automatic hammer falling 30 inches. The penetration resistance value is a useful index in estimating the consistency or relative density of materials encountered.

An automatic hammer was used to advance the split-barrel sampler in the borings performed on this site. A significantly greater efficiency is achieved with the automatic hammer compared to the conventional safety hammer operated with a cathead and rope. This higher efficiency has an appreciable effect on the SPT-N value. The effect of the automatic hammer's efficiency has been considered in the interpretation and analysis of the subsurface information for this report.

The samples were tagged for identification, sealed to reduce moisture loss, and taken to our laboratory for further examination, testing, and classification. Information provided on the boring logs attached to this report includes soil descriptions, consistency evaluations, boring depths, sampling intervals, and groundwater conditions. The borings were backfilled with auger cuttings and capped with concrete patch prior to the drill crew leaving the site.

Selected soils samples were tested for the following engineering properties:

- In-situ Dry Density
- Sieve Analysis
- Direct Shear Tests
- Soil Resistivity
- Sulfides
- In-situ Water Content
- Atterberg Limits
- pH
- Chlorides
- Red-Ox Potential

### **3.2 Typical Subsurface Profile**

Based on the results of the borings, the subsurface conditions encountered at each project site are presented below:

- Alhambra Wash: Predominantly interbedded layers of loose to dense sand with variable amounts of gravel, silt and clay, and medium stiff to very stiff clay with variable amounts of sand to the maximum depth explored to about 50 feet bgs.
- Eaton Wash: Predominantly loose to dense sand with variable amounts of silt to the maximum depth explored to about 50 feet bgs. A silt with variable amount of sand layer was encountered between the approximate depths of 7.5 and 25 feet bgs.
- Rubio Wash: Undocumented fill was encountered to the depth of about 12 to 15 feet bgs. The fill materials consist of sand with variable amounts of silt and clay. Below the fill, subsurface conditions consisted predominantly of loose to dense sand with variable amounts of silt and clay to the maximum depth explored to about 50 feet bgs. A soft to medium stiff silty clay with variable amounts of sand was encountered between the approximate depths of 25 and 35 feet bgs.

Fill materials were encountered at the Rubio Wash project site to the depth of about 12 to 15 bgs at the boring locations. However, the depth to the fill materials may be deeper than 15 feet within the project site. Furthermore, Terracon does not have any documentation indicating if these fill materials were monitored during placement. Field blow counts indicate the fill materials may not have received adequate effort during placement.

Laboratory tests were conducted on selected soil samples and the test results are presented in Appendix B. The Atterberg limits test results indicated that the onsite materials exhibit low to medium plasticity. Direct shear tests were performed on sandy materials encountered at various depths and indicated ultimate friction angles of 29° to 40° with corresponding cohesion values up to 384 psf.

### **3.3 Groundwater**

Groundwater was not encountered in any of the borings at each project site. These observations represent groundwater conditions at the time of the field exploration and may not be indicative of other times, or at other locations.

Groundwater level fluctuations occur due to seasonal variations in the amount of rainfall, runoff and other factors not evident at the time the borings were performed. Therefore, groundwater levels during construction or at other times in the life of the structure may be higher or lower than the levels indicated on the boring logs. The possibility of groundwater level fluctuations should be considered when developing the design and construction plans for the project.

Based on the LA County Public Work Historical Well Measurement Data, the historic high groundwater elevations are presented below for each site:

- Alhambra Wash: Elevation of 193 feet above mean sea level. This corresponds to approximate depth of about 50 feet bgs at the project site.<sup>1</sup>
- Eaton Wash: Elevation of 235 feet above mean sea level. This corresponds to approximate depth of about 28 feet bgs at the project site.<sup>2</sup>
- Rubio Wash: Elevation of 225 feet above mean sea level. This corresponds to approximate depth of about 25 feet bgs at the project site.<sup>3</sup>

---

<sup>1</sup> Los Angeles County groundwater monitoring well # 2915D which is located about 800 feet south of the project site. The data was obtained between 1972 and 2015.

<sup>2</sup> Los Angeles County groundwater monitoring well # 2942G which is located about 675 feet northwest of the project site. The data was obtained between 1972 and 2009.

<sup>3</sup> Los Angeles County groundwater monitoring well # 2933H which is located about 800 feet north of the project site. The data was obtained between 1972 and 2015.



### 3.4 Seismic Considerations

#### 3.4.1 Seismic Site Classification Parameters

The seismic design requirements for buildings and other structures are based on Seismic Design Category. Site Classification is required to determine the Seismic Design Category for a structure. The Site Classification is based on the upper 100 feet of the site profile defined by a weighted average value of either shear wave velocity, standard penetration resistance, or undrained shear strength in accordance with Section 20.4 of ASCE 7.

Description	Alhambra Wash	Eaton Wash	Rubio Wash
<b>2016 California Building Code Site Classification (CBC) <sup>1</sup></b>	D	D	D
<b>Site Latitude</b>	34.0514°N	34.0732°N	34.0649°N
<b>Site Longitude</b>	118.0832°W	118.0555°W	118.0678°W

1. Seismic site classification in general accordance with the *2016 California Building Code*.

#### 3.4.2 Faulting and Estimated Ground Motions

All three project sites are located in Southern California, which is a seismically active area. The type and magnitude of seismic hazards affecting the site are dependent on the distance to causative faults, the intensity, and the magnitude of the seismic event. As calculated using the USGS Unified Hazard Tool, the Elysian Park (Upper) Fault is considered to have the most significant effect at each of the project sites from a design standpoint. This fault has a maximum credible earthquake magnitude of 6.48. Distance to this fault from each project sites are presented in the table below.

Based on the OSHPD Seismic Design Maps, using the American Society of Civil Engineers (ASCE 7-10) standard, the peak ground acceleration ( $PGA_M$ ) at each of the project site are presented in the table below. Based on the USGS Unified Hazard Tool, each of the project site has mean magnitudes presented in the table below.

Project Site	Distance to Nearest Fault (kilometers) <sup>1</sup>	Mean Magnitude <sup>1</sup>	Peak Ground Acceleration ( $PGA_M$ ) <sup>2</sup>
Alhambra Wash	5.23	6.87	0.93
Eaton Wash	5.69	6.92	0.909
Rubio Wash	5.16	6.89	0.925

Note:

1. Based on USGS Unified Hazard Tool
2. Based on OSHPD Seismic Design Maps, using the ASCE 7-10 standard

Furthermore, Eaton Wash and Rubio Wash project sites are not located within an Alquist-Priolo (AP) Earthquake Fault Zone based on our review of the State Fault Hazard Maps.<sup>4</sup> However, Alhambra Wash project site is located within AP Earthquake Fault Zone. Based on the proposed projects and the low risk they present to human life in case of failure, we assumed that fault rupture studies are not required and therefore, additional fault rupture studies have not been performed.

### **3.4.3 Liquefaction**

Liquefaction is a mode of ground failure that results from the generation of high pore water pressures during earthquake ground shaking, causing loss of shear strength. Liquefaction is typically a hazard where loose sandy soils exist below groundwater. The California Geological Survey (CGS) has designated certain areas as potential liquefaction hazard zones. These are areas considered at a risk of liquefaction-related ground failure during a seismic event, based upon mapped surficial deposits and the presence of a relatively shallow water table.

All three project sites are located within a liquefaction potential zones as indicated by the CGS. Based on the materials encountered at the project site, subsurface conditions encountered at these project sites are predominantly interbedded coarse- and fine-grained soils to the depth of about 50 feet bgs. Historical high groundwater in the project vicinity are presented in Section 3.3.

Liquefaction analyses for all three project sites were performed in general accordance with the DMG Special Publication 117. The liquefaction study utilized the software “LiquefyPro” by CivilTech Software. This analysis was based on the soils data from Borings BA-1, BE-1 and BR-1 in Alhambra Wash, Eaton Wash and Rubio Wash, respectively. Peak Ground Acceleration (PGA) presented in Section 3.4.2 were used for each site. Calculations utilized conservative historical high groundwater elevations. Settlement analysis used the Tokimatsu, M-correction method. Fines were corrected for liquefaction using modified Stark and Olson. Liquefaction potential analysis was performed from a depth of 0 to 50 feet bgs. Liquefaction potential analysis is attached in Appendix D of this report.

Based on the subsurface conditions encountered in Borings BA-1, BE-1 and BR-1, historical high groundwater elevations, and laboratory test results, liquefiable saturated sands are encountered below the historical high groundwater elevation at Rubio Wash only. Liquefiable saturated sands are not encountered below the historical high groundwater elevation at Alhambra Wash and Eaton Wash. Based on the calculation results, the seismically-induced saturated and dry sand settlements are presented in the table below:

---

<sup>4</sup> California Department of Conservation Division of Mines and Geology (CDMG), “*Digital Images of Official Maps of Alquist-Priolo Earthquake Fault Zones of California, Southern Region*”, CDMG Compact Disc 2000-003, 2000.

Project Location	Boring	Seismically-Induced Saturated Sand Settlement (inch)		Seismically-Induced Dry Sand Settlement (inch)	
		Below Existing Ground Surface	Below Bottom of Vault Structure located at 18 feet bgs	Below Existing Ground Surface	Below Bottom of Vault Structure located at 18 feet bgs
Alhambra Wash	BA-1	0	0	1.8	0.6
Eaton Wash	BE-1	0.1	0.1	3	1.6
Rubio Wash	BR-1	1.5	1.5	4.6	1.2

Liquefiable layers are encountered in Rubio Wash project site below the depth of about 35 feet bgs. Liquefiable layers are not encountered in Alhambra Wash and Eaton Wash project sites. Since the liquefiable layers at Eaton Wash are at deeper depth compared to the depth of nearby channel wall, and liquefiable layers were not encountered at the Alhambra Wash and Eaton Wash, the susceptibility to earthquake-induced lateral spread is not considered to be design issue at each of the project site.

### 3.5 Percolation Test Results

Within each project site, one (1) in-situ percolation tests (using falling head borehole permeability) were performed to approximate depths of 20 to 25 feet bgs. A 2-inch thick layer of gravel was placed in the bottom of each boring after the borings were drilled to investigate the soil profile. A 3-inch diameter perforated pipe was installed on top of the gravel layer in each boring. Gravel was used to backfill between the perforated pipes and the boring sidewall to the top depth of the zone of percolation. Above the zone of percolation, the top of this gravel layer was filled with bentonite. The borings were then filled with water for a pre-soak period. At the beginning of each test, the pipes were refilled with water and readings were taken at standardized time intervals. Percolation rates are provided in the following table:

TEST RESULTS				
Project Location	Test Location (depth, feet bgs)	Slowest Measured Percolation Rate (in/hr)	Correlated Infiltration Rate <sup>1</sup> (in/hr)	Water Head (in)
Alhambra Wash	PA-1 (20 – 25 ft)	1.7	0.11	59
Eaton Wash	PE-1 (20 – 25 ft)	1	0.06	54
Rubio Wash	PR-1 (20 – 25 ft)	0.7	0.09	27

<sup>1</sup> If the proposed infiltration systems will mainly rely on vertical downward seepage, the correlated infiltration rates should be used. The correlated infiltration rates were calculated using the LA County Reduction Factor Method.

Based on our test results, the correlated infiltration rates were found to be less than 0.3 in/hr between depths of 20 and 25 feet bgs. Since the project site is located within the liquefaction potential hazard zone, liquefaction analyses were performed considering the historical high

## Geotechnical Engineering Report

SGVCOG ACE Rio Hondo Load Reduction Strategy Design Project  
San Gabriel Valley, CA ■ March 6, 2019 ■ Terracon Project No. 60185184



groundwater elevations. Based on the liquefaction analysis, the seismically-induced total saturated and dry sand settlements are 1.8, 3.1 and 6.1 inches at Alhambra Wash, Eaton Wash and Rubio Wash. Therefore, the liquefaction hazard potential is considered medium to high at all three sites.

The field test results are not intended to be design rates. They represent the result of our tests, at the depths and locations indicated, as described above. The design rate should be determined by the designer by applying an appropriate factor of safety. Based on the County of Los Angeles Department of Public Works GS200.2 document, the following reduction factors are recommended:

LA County Reduction Factor	Value
$RF_t$	2
$RF_v$	1
$RF_s^*$	2*
RF, Total Reduction Factor $RF=RF_t \times RF_v \times RF_s$	4*

\* If the stormwater will be treated prior to infiltration into the proposed infiltration system, the reduction factor  $RF_s$  may be changed to 1 and therefore, the resulting total reduction factor RF may be changed to 2.

With time, the bottoms of infiltration systems tend to plug with organics, sediments, and other debris. Long term maintenance will likely be required to remove these deleterious materials to help reduce decreases in actual percolation rates.

The percolation test was performed with clear water, whereas the storm water will likely not be clear, but may contain organics, fines, and grease/oil. The presence of these deleterious materials will tend to decrease the rate that water percolates from the infiltration systems. Design of the storm water infiltration systems should account for the presence of these materials and should incorporate structures/devices to remove these deleterious materials.

Based on the soils encountered in our borings, we expect the percolation rates of the soils could be different than measured in the field due to variations in fines and gravel content. The design elevation and size of the proposed infiltration system should account for this expected variability in infiltration rates.

Infiltration testing should be performed after construction of the infiltration system to verify the design infiltration rates. It should be noted that siltation and vegetation growth along with other factors may affect the infiltration rates of the infiltration areas. The actual infiltration rate may vary from the values reported here. Infiltration systems should be located a minimum of 20 feet from any existing or proposed foundation system and existing channel wall.

### 3.6 Corrosion Potential

Results of soluble sulfate testing indicate that ASTM Type I/II Portland cement may be used for all concrete on and below grade. Structural concrete may be designed for sulfate exposure category class S0 in accordance with the provisions of the ACI Design Manual, Section 318, Chapter 19.

Laboratory test results are presented in the table below. These values should be used to evaluate corrosive potential of the on-site soils to underground ferrous metals.

Project Site	pH	Resistivity (ohm-cm)	Chlorides (mg/kg)	Water Soluble Sulfate (%)	Red-Ox (mV)
Alhambra Wash	8.28	1,455	42	0.01	+683
Eaton Wash	8.37	3,589	43	0.01	+677
Rubio Wash	8.56	3,783	53	0.01	+677

Refer to the Results of Corrosivity Analysis sheet in Appendix B for the complete results of the corrosivity testing conducted in conjunction with this geotechnical exploration.

## 4.0 RECOMMENDATIONS FOR DESIGN AND CONSTRUCTION

### 4.1 Pump Station Structure Foundation

Based on the information provided by client, pump stations are proposed at each project site. We understand that the pump station will be installed in to below ground vault. The bottom of the vaults is proposed to be at the depth of about 18 feet below ground surface. These vault structures will be supported on mat foundation systems.

Liquefaction induced total settlements are about 0.6, 1.6 and 2.7 inches below the bottom of the pump station in Alhambra Wash, Eaton Wash and Rubio Wash, respectively. However, it is our understanding that these proposed vault structures are underground monolithic non-human occupancy structures. Therefore, these structures do not pose a significant risk on human life in case of failure during a seismic event.

The following foundation recommendations are presented for the mat foundation systems for the vault structure:

DESCRIPTION	RECOMMENDATIONS: ALHAMBRA WASH, EATON WASH AND RUBIO WASH
<b>Structures</b>	Proposed pump station vault
<b>Foundation Type</b>	Reinforced mat foundations
<b>Bearing Material</b>	A minimum of 18 inches of engineered fill comprised of low volume change imported materials.
<b>Design Modulus of Subgrade Reaction, k*</b>	120 pci
<b>Modulus Correction Factor*</b>	$k_c = k/b$
<b>Allowable Bearing Capacity</b>	1,500 psf
<b>Minimum Width</b>	24 inch
<b>Minimum Depth</b>	18 feet below existing ground surface
<b>Total Estimated Static Settlement</b>	1 inch or less
<b>Estimated Differential Settlement</b>	½ inch

\*It is common to reduce the k-value to account for dimensional effects of large loaded areas. Where  $k_c$  is the corrected or design modulus value and b is the mat width in feet.

Foundation excavations should be observed by the geotechnical engineer. If the soil conditions encountered differ significantly from those presented in this report, supplemental recommendations will be required.

## 4.2 Lateral Earth Pressure

### 4.2.1 Cantilevered Shoring Recommendations

The lateral earth pressure recommendations herein are applicable to the design of cantilevered shoring system. The lateral earth pressures are based on the free draining level backfill conditions. The parameters below consider a soil profile of existing soils as backfill materials:

ITEM	VALUE		
	Alhambra Wash and Rush Street	Eaton Wash	Rubio Wash
Active Case Backfill	38 psf/ft	40 psf/ft	43 psf/ft
Passive Case	375 psf/ft	360 psf/ft	330 psf/ft
At-Rest Case	58 psf/ft	60 psf/ft	64 psf/ft
Surcharge Pressure	0.3*(Surcharge)	0.33*(Surcharge)	0.36*(Surcharge)
Ultimate Coefficient of Friction	0.35	0.3	0.3

The lateral earth pressures herein do not include any factor of safety and are not applicable for submerged soils/hydrostatic loading. Additional recommendations may be necessary if such conditions are to be included in the design.

The design of any shoring system should consider surcharge loads imposed by the existing structures and vehicular loads in the vicinity of the shoring. In general, surcharge loads should be considered where they are located within a horizontal distance behind the shoring equal to the height of the shoring.

Surcharge loads acting at the top of the shoring should be applied to the shoring over the backfill as a uniform pressure over the entire shoring height and should be added to the static earth pressures. Surcharge stresses due to point loads, line loads, and those of limited extent, such as compaction equipment, should be evaluated using elastic theory.

### 4.2.2 Braced Shoring Recommendations

For the design of braced shoring, we recommend such shoring be designed using a rectangular-shaped distribution of lateral earth pressure of 25H, 26H, 28H (in psf) (H is the total height of excavation) in Alhambra Wash and Rush Street, Eaton Wash, and Rubio Wash, respectively.

The design of the shored excavation should be performed by an engineer knowledgeable and experienced with the on-site soil conditions. The contractor should be aware that slope height, slope inclination or excavation depths should in no case exceed those specified in local, state or federal safety regulations, e.g. OSHA Health and Safety Standards for Excavation, 29 CFR Part 1926, or successor regulations. Such regulations are strictly enforced and, if not followed, the owner or the contractor could be liable for substantial penalties.

### 4.3 Pavements

#### 4.3.1 Design Recommendations

Estimated design R-Values were used to calculate the asphalt concrete pavement thickness sections and the portland cement concrete pavement sections. R-value testing should be completed prior to pavement construction to verify the design R-value.

Assuming the pavement subgrades will be prepared as recommended within this report, the following pavement sections should be considered minimums for this project for the traffic indices assumed in the table below. As more specific traffic information becomes available, we should be contacted to reevaluate the pavement calculations.

<b>Alhambra Wash, Eaton Wash and Rubio Wash</b>		
	<b>Recommended Pavement Section Thickness (inches)*</b>	
	<b>Light (Automobile) Parking Assumed Traffic Index (TI) = 4.5</b>	<b>On-site Driveways and Delivery Areas, Assumed TI = 5.5</b>
<u>Section I</u> Portland Cement Concrete (600 psi Flexural Strength)	5-inches PCC over 4-inches Class II Aggregate Base	6-inches PCC over 4-inches Class II Aggregate Base
<u>Section II</u> Asphaltic Concrete	3-inches AC over 4-inches Class II Aggregate Base	3-inches AC over 6-inches Class II Aggregate Base

<b>Rush Street</b>		
<b>Recommended Pavement Section Thickness (inches)*</b>		
<b>Traffic Index (TI) = 7.0</b>	<b>Traffic Index (TI) = 8.0</b>	<b>Traffic Index (TI) = 9.0</b>
4-inches AC over 7-inches Class II Aggregate Base Or 5-inches AC over 5-inches Class II Aggregate Base Or 6-inches AC over 4-inches Class II Aggregate Base	4-inches AC over 10-inches Class II Aggregate Base Or 5-inches AC over 8-inches Class II Aggregate Base Or 6-inches AC over 6-inches Class II Aggregate Base	4-inches AC over 12-inches Class II Aggregate Base Or 5-inches AC over 10-inches Class II Aggregate Base Or 6-inches AC over 8-inches Class II Aggregate Base

\* All materials should meet the CALTRANS Standard Specifications for Highway Construction.

All pavements should be supported on a minimum of 10 inches of scarified, moisture conditioned, and compacted materials. The subgrade and aggregate base materials beneath the pavements should be compacted to minimum of 95% of relative compaction per the modified proctor test (ASTM D1557) with moisture contents ranging between -1% and +4% of optimum moisture content. These pavement sections are considered minimal sections based upon the expected traffic and the existing subgrade conditions. However, they are expected to function with periodic maintenance and overlays if good drainage is provided and maintained.



Undocumented fill materials are encountered within the Rubio Wash project site. Support of pavements on or above these existing fill materials is discussed in this report. However, even with the recommended construction testing services, there is an inherent risk for the owner that compressible fill or unsuitable material within or buried by the fill will not be discovered. This risk of unforeseen conditions cannot be eliminated without completely removing the existing fill, but can be reduced by performing additional testing and evaluation.

Subsequent to clearing, grubbing, and removal of topsoil, subgrade soils beneath all pavements should be scarified, moisture conditioned, and compacted to a minimum depth of 10 inches. All materials should meet the CALTRANS Standard Specifications for Highway Construction. Aggregate base materials should meet the gradation and quality requirement of Class 2 Aggregate Base (¾ inch maximum) in Caltrans Standard Specifications, latest edition, Sections 25 through 29.

All concrete for rigid pavements should have a minimum flexural strength of 600 psi (4,250 psi Compressive Strength), and be placed with a maximum slump of four inches. Proper joint spacing will also be required to prevent excessive slab curling and shrinkage cracking. All joints should be sealed to prevent entry of foreign material and dowelled where necessary for load transfer.

#### **4.3.2 Construction Considerations**

Materials and construction of pavements for the project should be in accordance with the requirements and specifications of the State of California Department of Transportation, or other approved local governing specifications.

Base course or pavement materials should not be placed when the surface is wet. Surface drainage should be provided away from the edge of paved areas to minimize lateral moisture transmission into the subgrade.

Preventative maintenance should be planned and provided for through an on-going pavement management program in order to enhance future pavement performance. Preventative maintenance activities are intended to slow the rate of pavement deterioration, and to preserve the pavement investment.

Preventative maintenance consists of both localized maintenance (e.g. crack sealing and patching) and global maintenance (e.g. surface sealing). Preventative maintenance is usually the first priority when implementing a planned pavement maintenance program and provides the highest return on investment for pavements.

#### **4.4 Earthwork**

The recommendations presented are for the design and construction of earth supported elements are contingent upon following the recommendations outlined in this report.

Strip and remove existing pavements, vegetations, and other deleterious materials from proposed construction area. Exposed surfaces should be free of mounds and depressions which could prevent uniform compaction.

For the subgrade preparation of the foundation for the vault structure, a minimum of 18 inches of exposed soils should be overexcavated and replaced with engineered fill below the bottom of the foundation. Onsite sandy materials are considered suitable to be used as engineered fill materials.

Undocumented fill materials were encountered at the Rubio Wash project site to the depth of about 12 to 15 bgs at the boring locations. However, the depth to these fill materials may be deeper than 15 feet within the project site. Furthermore, Terracon does not have any documentation indicating if these fill materials were monitored during placement. Field blow counts indicate the fill materials may not have received adequate effort during placement. Fill materials will be encountered during construction and if encountered, these fill materials should be removed entirely within the structural areas.

All new fill materials should be inorganic soils free of vegetation, debris, and fragments larger than three inches in size. Pea gravel or other similar non-cementitious, poorly-graded materials should not be used as fill or backfill without the prior approval of the geotechnical engineer.

Within all three project sites, the on-site sandy soils are considered suitable to be used as backfill materials. Backfill materials should be mechanically placed and compacted to minimum of 90% of relative compaction per the modified proctor test (ASTM D1557) with moisture contents ranging between -1% and +4% of optimum moisture content. Backfill should be placed and compacted in horizontal lifts, using equipment and procedures that will produce recommended moisture contents and densities throughout the lift. Fill lifts should not exceed eight inches loose thickness.

Within all three project sites, it is anticipated that excavations for the proposed construction can be accomplished with conventional earthmoving equipment. Based upon the subsurface conditions determined from the geotechnical exploration, subgrade soils exposed during construction are anticipated to be relatively workable. However, the workability of the subgrade may be affected by precipitation, repetitive construction traffic or other factors. If unworkable conditions develop, workability may be improved by scarifying and drying.

On-site clayey soils may pump or become unworkable at high water contents. The workability of the subgrade may be affected by precipitation, repetitive construction traffic or other factors. Workability may be improved by scarifying and drying. Lightweight excavation equipment may be

required to reduce subgrade pumping. Should unstable subgrade conditions develop stabilization measures will need to be employed.

At the time of our study, moisture contents of the surface and near-surface native soils ranged from about 5 to 20 percent within all the project sites. Based on these moisture contents, some moisture conditioning may be needed for the project. The soils may need to be dried by aeration during dry weather conditions, or an additive, such as lime, cement, or kiln dust, may be needed to stabilize the soil. If the construction schedule does not allow for drying by aeration, clay sand soils may be stabilized using triaxial geogrid and coarse aggregate materials.

The geotechnical engineer should be retained during the construction phase of the project to observe earthwork and to perform necessary tests and observations during subgrade preparation, proof-rolling, placement and compaction of controlled compacted fills, backfilling of excavations to the completed subgrade.

We recommend that the earthwork portion of this project be completed during extended periods of dry weather if possible. If earthwork is completed during the wet season (typically November through April) it may be necessary to take extra precautionary measures to protect subgrade soils. Wet season earthwork operations may require additional mitigation measures beyond that which would be expected during the drier summer and fall months. This could include diversion of surface runoff around exposed soils and draining of ponded water on the site. Once subgrades are established, it may be necessary to protect the exposed subgrade soils from construction traffic.

The individual contractor(s) is responsible for designing and constructing stable, temporary excavations as required to maintain stability of both the excavation sides and bottom. Excavations should be sloped or shored in the interest of safety following local, and federal regulations, including current OSHA excavation and trench safety standards.

Within all three project sites, underground utility lines may be encountered during construction. Furthermore, evidence of underground facilities such as septic tanks, cesspools, and basements was not observed during the site reconnaissance, such features could be encountered during construction. If unexpected fills or utility lines or underground facilities are encountered, such features should be removed, and the excavation thoroughly cleaned prior to backfill placement and/or construction.

#### **4.4.1 Excavations**

Up to 18 feet of excavation is anticipated for the construction of the infiltration system and pump station within each project site. Furthermore, in Alhambra Wash project site, up to 10 feet of excavation is anticipated along the Rush Street for the installation of the diversion pipes. The individual contractor(s) is responsible for designing and constructing stable, temporary excavations as required to maintain stability of both the excavation sides and bottom. The sides

of excavations may either be sloped or formed with vertical cuts. For vertical sided excavations greater than 5 feet in depth, the excavations will require the use of shoring, bracing or some form of retention to prevent sloughing and caving of the soil into the excavation. The individual contractor(s) is responsible for temporary shoring design. The lateral earth pressure recommendations are presented in Section 4.2.1.

For the excavation of temporary slopes, the subsurface soils consisting of the granular materials can be considered Type C soils when applying the OSHA. OSHA allows a maximum slope inclination of 1½H:1V for Type C soils in excavations of 20 feet or less. Flatter slopes may be required if caving soils or seepage is encountered in any excavation. Furthermore, care should be taken during excavation to avoid any sloughing and raveling of the side slopes. If any sloughing and raveling observed, the slope should be benched as necessary. Based on OSHA guidelines, the maximum height of the bench should be 4 feet.

Based on the proposed construction, excavations deeper than 20 feet are not anticipated. However, if excavations deeper than 20 feet will be needed, slope stability analyses should be performed to determine the configuration of the temporary slopes.

Existing washes are concrete lined channels running adjacent to the project site. Any excavation adjacent to the existing channels should follow the Los Angeles County Flood Control excavation guidelines.

In nonstructural areas, the upper 10 inches at the bottom of the excavation should be scarified, moisture conditioned, and compacted to minimum of 90% of relative compaction per the modified proctor test (ASTM D1557) with moisture contents ranging between -1% and +4% of optimum moisture content.

The exposed soils in all excavations should be monitored by the responsible geotechnical engineer. This will provide an opportunity to modify the excavation slopes as necessary. It also offers an opportunity to verify the stability of the excavation slopes during construction.

#### **4.4.2 Open Trench Construction**

In Alhambra Wash project site, up to 10 feet of open trench excavation is anticipated along the Rush Street for the installation of the diversion pipes. This open trench excavation should follow the recommendations presented in Section 4.4.1 for the excavations.

Any loose and/or unsuitable material encountered at the bottom of excavations should be removed and be replaced with an adequate bedding material. The pipe subgrade should be level, uniform, firm, unyielding, and free of loose material. Pipe subgrade should also be properly graded to provide uniform bearing and support to the entire section of the pipe, over size particles larger than 2 inches in the largest dimension should be removed from the trench bottom and replaced with compacted materials. The compaction should confirm to minimum of 90% of relative

compaction per the modified proctor test (ASTM D1557) with moisture contents ranging between -1% and +4% of optimum moisture content.

Bedding is defined as the material supporting and surrounding the pipe to 12 inches above the pipe. To provide uniform and firm support for the pipe, compacted granular materials such as clean sand may be used as pipe bedding material. The type and thickness of the granular bedding placed underneath and around the pipe, if any, should be selected by the pipe manufacturer or design. Care should be taken to densify the bedding material below the spring line of the pipe. Pipe design generally requires a granular material with a sand equivalent (SE) greater than 30.

The sandy materials encountered in the project site are anticipated to be suitable as pipe bedding materials, provided they are screened and oversized particles are removed. During construction these stockpiled soils should be tested for conformance with the sand equivalent requirements set forth by the pipe manufacturer.

The on-sites sandy materials are considered suitable for use as trench backfill on the project, provided they are screened of large particles with dimensions larger than three (3) inches. The trench backfill materials should be mechanically placed and compacted to minimum of 90% of relative compaction per the modified proctor test (ASTM D1557) with moisture contents ranging between -1% and +4% of optimum moisture content. Backfill should be placed and compacted in horizontal lifts, using equipment and procedures that will produce recommended moisture contents and densities throughout the lift. Fill lifts should not exceed eight inches loose thickness.

#### **4.4.3 Below Grade Structures Considerations**

Based on our understanding of each of the project, we anticipate that excavations up to 18 feet below existing grades are planned for the construction of the infiltration system and pump station. For vertical sided excavations, the excavations will require the use of shoring, bracing or some form of retention to prevent sloughing and caving of the soil into the excavation.

As a safety measure, no equipment should be operated within 5 feet of the edge of the excavation and no materials should be stockpiled within 10 feet of the excavation. Excavations should not approach closer than 10 feet from existing structures/facilities without some form of protection for the facilities. Proper berm or ditch should be performed to divert any surface runoff away from the excavation.

Soils from the pits excavation should not be stockpiled higher than six (6) feet or within ten (10) feet of the edge of an open trench. Construction of open cuts adjacent to existing structures, including underground pipes, is not recommended within a 1½ H:1V plane extending beyond and down from the perimeter of structures. Cuts that are proposed within five (5) feet of light standards, other utilities, underground structures, and pavement should be provided with temporary shoring.

#### **4.4.4 Utility Trenches**

It is anticipated that the on-site soils will provide suitable support for underground utilities and piping that may be installed. Any loose and/or unsuitable material encountered at the bottom of excavations should be removed and be replaced with an adequate bedding material. A non-expansive granular material with a sand equivalent greater than 30 is recommended for bedding and shading of utilities, unless otherwise allowed by the utility manufacturer.

On-site materials are considered suitable for backfill of utility and pipe trenches from one foot above the top of the pipe to the final ground surface, provided the material is free of organic matter and deleterious substances. Trench backfill should be mechanically placed and compacted to minimum of 90% of relative compaction (upper 12 inches should be compacted to 95% of relative compaction within the pavements) per the modified proctor test (ASTM D1557) with moisture contents ranging between -1% and +4% of optimum moisture content. Compaction of initial lifts should be accomplished with hand-operated tampers or other lightweight compactors. Where trenches are placed beneath footings, the backfill should satisfy the gradation and expansion index requirements of engineered fill. Flooding or jetting for placement and compaction of backfill is not recommended.

## **5.0 GENERAL COMMENTS**

Terracon should be retained to review the final design plans and specifications, so comments can be made regarding interpretation and implementation of our geotechnical recommendations in the design and specifications. Terracon also should be retained to provide observation and testing services during grading, excavation, foundation construction and other earth-related construction phases of the project.

The analysis and recommendations presented in this report are based upon the data obtained from the borings performed at the indicated locations and from other information discussed in this report. This report does not reflect variations that may occur between borings, across the site, or due to the modifying effects of construction or weather. The nature and extent of such variations may not become evident until during or after construction. If variations appear, we should be immediately notified so that further evaluation and supplemental recommendations can be provided.

The scope of services for this project does not include either specifically or by implication any environmental or biological (e.g., mold, fungi, bacteria) assessment of the site or identification or prevention of pollutants, hazardous materials or conditions. If the owner is concerned about the potential for such contamination or pollution, other studies should be undertaken.

This report has been prepared for the exclusive use of our client for specific application to the project discussed and has been prepared in accordance with generally accepted geotechnical engineering practices. No warranties, either express or implied, are intended or made. Site safety, excavation support, and dewatering requirements are the responsibility of others. In the event that changes in the nature, design, or location of the project as outlined in this report are planned, the conclusions and recommendations contained in this report shall not be considered valid unless Terracon reviews the changes and either verifies or modifies the conclusions of this report in writing.

**APPENDIX A**  
**FIELD EXPLORATION**



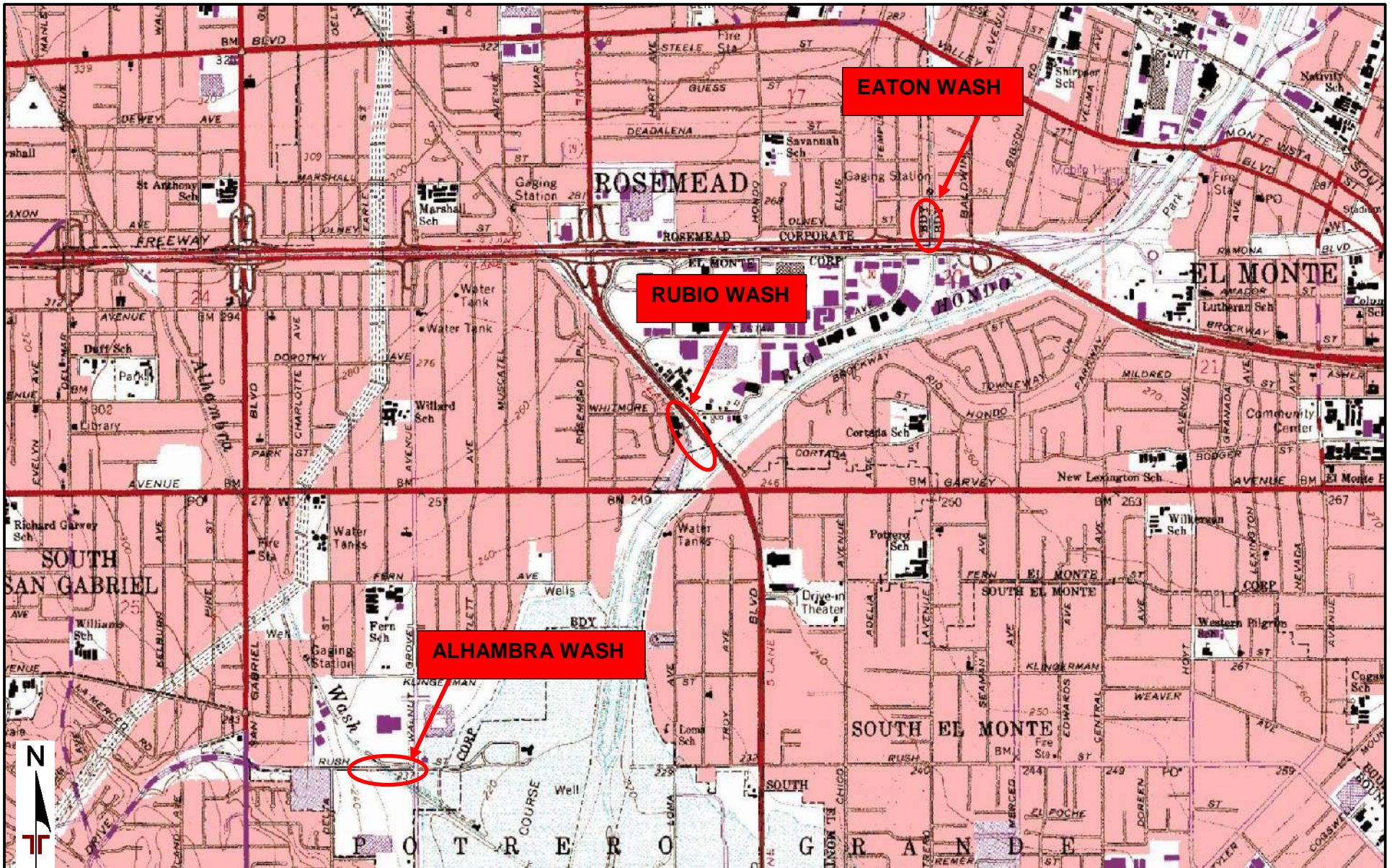

TOPOGRAPHIC MAP IMAGE COURTESY OF THE U.S. GEOLOGICAL SURVEY  
 QUADRANGLES INCLUDE: EL MONTE, CA (1/1/1994).

DIAGRAM IS FOR GENERAL LOCATION ONLY, AND IS NOT INTENDED FOR CONSTRUCTION PURPOSES

Project Manager:	SP	Project No.	60185184
Drawn by:	SP	Scale:	1"=2,000'
Checked by:	FFB	File Name:	A-1
Approved by:	FFB	Date:	MAR 2019

**Terracon**

1421 Edinger Ave, Ste C  
 Tustin, CA 92780-6287



**SITE LOCATION**

SGVCOG ACE Rio Hondo Load Reduction Strategy  
 Design  
 Alhambra, Eaton, and Rubio Wash  
 San Gabriel Valley, CA

Exhibit

**A-1**

## LEGEND

-  BA-1: APPROXIMATE BORING LOCATION
-  PA-1: APPROXIMATE PERCOLATION TEST LOCATION



AERIAL PHOTOGRAPHY PROVIDED BY MICROSOFT BING MAPS

DIAGRAM IS FOR GENERAL LOCATION ONLY, AND IS NOT INTENDED FOR CONSTRUCTION PURPOSES

Project Manager:	SP	Project No.	60185184
Drawn by:	SP	Scale:	AS SHOWN
Checked by:	FFB	File Name:	A-2A
Approved by:	FFB	Date:	MAR 2019

Terracon

1421 Edinger Ave, Ste C  
Tustin, CA 92780-6287



EXPLORATION PLAN

SGVCOG ACE Rio Hondo Load Reduction Strategy  
Design  
Alhambra Wash  
San Gabriel Valley, CA

Exhibit  
A-2A



**LEGEND**

-  **BE-1: APPROXIMATE BORING LOCATION**
-  **PE-1: APPROXIMATE PERCOLATION TEST LOCATION**

AERIAL PHOTOGRAPHY PROVIDED BY MICROSOFT BING MAPS

DIAGRAM IS FOR GENERAL LOCATION ONLY, AND IS NOT INTENDED FOR CONSTRUCTION PURPOSES



Project Manager:	SP	Project No.	60185184
Drawn by:	SP	Scale:	AS SHOWN
Checked by:	FFB	File Name:	A-2B
Approved by:	FFB	Date:	MAR 2019

**Terracon**  
 1421 Edinger Ave, Ste C  
 Tustin, CA 92780-6287

**EXPLORATION PLAN**  
 GVCOG ACE Rio Hondo Load Reduction Strategy  
 Design  
 Eaton Wash  
 San Gabriel Valley, CA

Exhibit  
 A-2B

## LEGEND

-  BR-1: APPROXIMATE BORING LOCATION
-  PR-1: APPROXIMATE PERCOLATION TEST LOCATION



bing

200 feet

© 2019 Microsoft Corporation

AERIAL PHOTOGRAPHY PROVIDED BY MICROSOFT BING MAPS

DIAGRAM IS FOR GENERAL LOCATION ONLY, AND IS NOT INTENDED FOR CONSTRUCTION PURPOSES

Project Manager:	SP	Project No.	60185184
Drawn by:	SP	Scale:	AS SHOWN
Checked by:	FFB	File Name:	A-2C
Approved by:	FFB	Date:	MAR 2019

**Terracon**

1421 Edinger Ave, Ste C  
Tustin, CA 92780-6287

### EXPLORATION PLAN

SGVCOG ACE Rio Hondo Load Reduction Strategy  
Design  
Rubio Wash  
San Gabriel Valley, CA

Exhibit

A-2C

# BORING LOG NO. BA-1

**PROJECT: SGVCOG ACE Rio Hondo Load Reduction Strategy Design Project**

**CLIENT: CWE Corp  
Fullerton, CA**

**SITE: Alhambra Wash, Eaton Wash, Rubio Wash  
San Gabriel Valley, Los Angeles County, CA**

GRAPHIC LOG	LOCATION See Exhibit A-2 Latitude: 34.0513° Longitude: -118.0831°	DEPTH (Ft.)	WATER LEVEL OBSERVATIONS	SAMPLE TYPE	FIELD TEST RESULTS	STRENGTH TEST			WATER CONTENT (%)	DRY UNIT WEIGHT (pcf)	ATTERBERG LIMITS	
						TEST TYPE	COMPRESSIVE STRENGTH (tsf)	STRAIN (%)			LL-PL-PI	PERCENT FINES
DEPTH												
<b>CLAYEY SAND (SC)</b> , brown, loose		5		X	3-4-4 N=8					25-15-10		
medium dense		10.0		X	5-6-9 N=15							22
<b>CLAYEY SAND WITH GRAVEL (SC)</b> , olive brown, medium dense		15.0		X	6-8-8 N=16							
<b>SANDY LEAN CLAY (CL)</b> , brown, medium stiff, mica		20.0		X	2-3-4 N=7							61
<b>CLAYEY SAND (SC)</b> , dark brown, loose, mica		25.0		X	0-2-3 N=5					29-17-12		45
<b>LEAN CLAY (CL)</b> , yellowish brown, stiff				X	2-4-7 N=11							

Stratification lines are approximate. In-situ, the transition may be gradual.

Hammer Type: Automatic

Advancement Method:  
Hollow-stem auger

See Exhibit A-3 for description of field procedures.  
See Appendix B for description of laboratory procedures and additional data (if any).

Notes:

Abandonment Method:  
Boring backfilled with cement-bentonite grout upon completion.

See Appendix C for explanation of symbols and abbreviations.

**WATER LEVEL OBSERVATIONS**

*Groundwater not encountered*

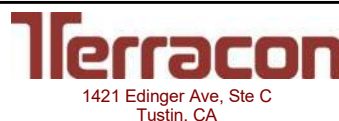

Boring Started: 02-12-2019

Boring Completed: 02-12-2019

Drill Rig: CME 75

Driller: Martini

Project No.: 60185184

Exhibit: A-3

THIS BORING LOG IS NOT VALID IF SEPARATED FROM ORIGINAL REPORT. GEO SMART LOG-NO WELL. 60185184 BORING LOGS.GPJ MODEL LAYER.GPJ 3/6/19

# BORING LOG NO. BA-1

**PROJECT:** SGVCOG ACE Rio Hondo Load Reduction Strategy Design Project

**CLIENT:** CWE Corp  
Fullerton, CA

**SITE:** Alhambra Wash, Eaton Wash, Rubio Wash  
San Gabriel Valley, Los Angeles County, CA

GRAPHIC LOG	LOCATION See Exhibit A-2 Latitude: 34.0513° Longitude: -118.0831°	DEPTH (Ft.)	WATER LEVEL OBSERVATIONS	SAMPLE TYPE	FIELD TEST RESULTS	STRENGTH TEST			WATER CONTENT (%)	DRY UNIT WEIGHT (pcf)	ATTERBERG LIMITS	PERCENT FINES
						TEST TYPE	COMPRESSIVE STRENGTH (tsf)	STRAIN (%)			LL-PL-PI	
30.0	<b>LEAN CLAY (CL)</b> , yellowish brown, stiff <i>(continued)</i>											
35.0	<b>POORLY GRADED SAND WITH SILT (SP-SM)</b> , olive brown, dense	30		X	12-18-25 N=43							7
40.0	<b>LEAN CLAY WITH SAND (CL)</b> , yellowish brown, stiff, mica	35		X	8-6-6 N=12							
45.0	<b>POORLY GRADED SAND WITH SILT (SP-SM)</b> , olive brown, dense	40		X	2-3-6 N=9							78
50.0	<b>POORLY GRADED SAND WITH SILT (SP-SM)</b> , olive brown, dense	45		X	10-16-21 N=37							7
51.5	<b>SILTY SAND (SM)</b> , olive brown, dense	50		X	8-15-20 N=35							
<b>Boring Terminated at 51.5 Feet</b>												

Stratification lines are approximate. In-situ, the transition may be gradual.

Hammer Type: Automatic

Advancement Method:  
Hollow-stem auger

See Exhibit A-3 for description of field procedures.  
See Appendix B for description of laboratory procedures and additional data (if any).  
See Appendix C for explanation of symbols and abbreviations.

Notes:

Abandonment Method:  
Boring backfilled with cement-bentonite grout upon completion.

**WATER LEVEL OBSERVATIONS**

Groundwater not encountered

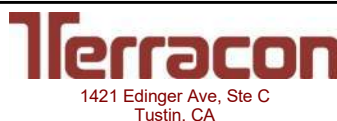

Boring Started: 02-12-2019

Boring Completed: 02-12-2019

Drill Rig: CME 75

Driller: Martini

Project No.: 60185184

Exhibit: A-3

THIS BORING LOG IS NOT VALID IF SEPARATED FROM ORIGINAL REPORT. GEO SMART LOG-NO WELL\_60185184 BORING LOGS.GPJ MODEL LAYER.GPJ 3/6/19

# BORING LOG NO. BA-2

**PROJECT: SGVCOG ACE Rio Hondo Load Reduction Strategy Design Project**

**CLIENT: CWE Corp  
Fullerton, CA**

**SITE: Alhambra Wash, Eaton Wash, Rubio Wash  
San Gabriel Valley, Los Angeles County, CA**

GRAPHIC LOG	LOCATION See Exhibit A-2 Latitude: 34.0514° Longitude: -118.0835°	DEPTH (Ft.)	WATER LEVEL OBSERVATIONS	SAMPLE TYPE	FIELD TEST RESULTS	STRENGTH TEST			WATER CONTENT (%)	DRY UNIT WEIGHT (pcf)	ATTERBERG LIMITS		PERCENT FINES
						TEST TYPE	COMPRESSIVE STRENGTH (tsf)	STRAIN (%)			LL-PL-PI		
	<p><b>CLAYEY SAND WITH GRAVEL (SC)</b>, brown, medium dense</p>	5		X	8-20-20			10	127				
		7.5	<p><b>SILTY SAND (SM)</b>, trace gravel, olive brown, medium dense</p>	10		X	8-12-12 N=24						
		15.0		11-12-15		X	8-4-6 N=10		15	120	23-20-3	21	
		20	<p><b>SANDY LEAN CLAY (CL)</b>, dark gray, stiff, mica</p> <p>yellowish brown</p>	25		X	2-5-10		16	114			
		26.5		2-4-7 N=11		X					40-16-24	69	
<p><b>Boring Terminated at 26.5 Feet</b></p>													

Stratification lines are approximate. In-situ, the transition may be gradual.

Hammer Type: Automatic

Advancement Method:  
Hollow-stem auger

See Exhibit A-3 for description of field procedures.  
See Appendix B for description of laboratory procedures and additional data (if any).  
See Appendix C for explanation of symbols and abbreviations.

Notes:

Abandonment Method:  
Boring backfilled with cement-bentonite grout upon completion.

**WATER LEVEL OBSERVATIONS**

Groundwater not encountered

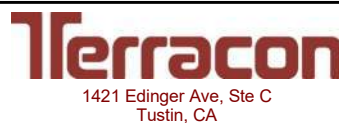

Boring Started: 02-12-2019

Boring Completed: 02-12-2019

Drill Rig: CME 75

Driller: Martini

Project No.: 60185184

Exhibit: A-4

THIS BORING LOG IS NOT VALID IF SEPARATED FROM ORIGINAL REPORT. GEO SMART LOG-NO WELL\_60185184 BORING LOGS.GPJ MODEL LAYER.GPJ 3/6/19

# BORING LOG NO. BA-3

**PROJECT: SGVCOG ACE Rio Hondo Load Reduction Strategy Design Project**

**CLIENT: CWE Corp  
Fullerton, CA**

**SITE: Alhambra Wash, Eaton Wash, Rubio Wash  
San Gabriel Valley, Los Angeles County, CA**

GRAPHIC LOG	LOCATION See Exhibit A-2 Latitude: 34.0516° Longitude: -118.084°	DEPTH (Ft.)	WATER LEVEL OBSERVATIONS	SAMPLE TYPE	FIELD TEST RESULTS	STRENGTH TEST			WATER CONTENT (%)	DRY UNIT WEIGHT (pcf)	ATTERBERG LIMITS	
						TEST TYPE	COMPRESSIVE STRENGTH (tsf)	STRAIN (%)			LL-PL-PI	PERCENT FINES
	DEPTH											
0.4	<b>ASPHALT</b> , 5" thickness											
1.3	<b>AGGREGATE BASE COURSE</b> , 10" thickness <b>CLAYEY SAND (SC)</b> , dark borwn, medium dense											
5.0	<b>CLAYEY SAND WITH GRAVEL (SC)</b> , dark brown, medium dense	5		X	5-15-16 8-16-10 N=26			9	127			
8.5	<b>CLAYEY SAND (SC)</b> , trace gravel, olive brown, loose											
10.0	<b>Boring Terminated at 10 Feet</b>	10			3-4-4			10	108		35	

Stratification lines are approximate. In-situ, the transition may be gradual.

Hammer Type: Automatic

Advancement Method:  
Hollow-stem auger

See Exhibit A-3 for description of field procedures.  
See Appendix B for description of laboratory procedures and additional data (if any).

Notes:

Abandonment Method:  
Boring backfilled with Auger Cuttings  
Surface capped with asphalt

See Appendix C for explanation of symbols and abbreviations.

**WATER LEVEL OBSERVATIONS**

Groundwater not encountered

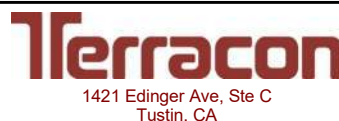

Boring Started: 02-12-2019

Boring Completed: 02-12-2019

Drill Rig: CME 75

Driller: Martini

Project No.: 60185184

Exhibit: A-5

THIS BORING LOG IS NOT VALID IF SEPARATED FROM ORIGINAL REPORT. GEO SMART LOG-NO WELL\_ 60185184 BORING LOGS.GPJ MODEL LAYER.GPJ 3/6/19



# BORING LOG NO. BA-4

**PROJECT: SGVCOG ACE Rio Hondo Load Reduction Strategy Design Project**

**CLIENT: CWE Corp  
Fullerton, CA**

**SITE: Alhambra Wash, Eaton Wash, Rubio Wash  
San Gabriel Valley, Los Angeles County, CA**

GRAPHIC LOG	LOCATION See Exhibit A-2 Latitude: 34.0516° Longitude: -118.0855°	DEPTH (Ft.)	WATER LEVEL OBSERVATIONS	SAMPLE TYPE	FIELD TEST RESULTS	STRENGTH TEST			WATER CONTENT (%)	DRY UNIT WEIGHT (pcf)	ATTERBERG LIMITS	
						TEST TYPE	COMPRESSIVE STRENGTH (tsf)	STRAIN (%)			LL-PL-PI	PERCENT FINES
	0.4	<b>ASPHALT</b> , 5" thickness										
	1.5	<b>AGGREGATE BASE COURSE</b> , 13" thickness										
	5.0	<b>CLAYEY SAND WITH GRAVEL (SC)</b> , brown, medium dense		X	2-4-7 N=11							
	10.0	<b>CLAYEY SAND (SC)</b> , brown, medium dense	5	X	10-18-26			11	118			49
		10.0		X	4-7-8 N=15							
	<b>Boring Terminated at 10 Feet</b>											

Stratification lines are approximate. In-situ, the transition may be gradual.

Hammer Type: Automatic

Advancement Method:  
Hollow-stem auger

See Exhibit A-3 for description of field procedures.  
See Appendix B for description of laboratory procedures and additional data (if any).

Notes:

Abandonment Method:  
Boring backfilled with Auger Cuttings  
Surface capped with asphalt

See Appendix C for explanation of symbols and abbreviations.

**WATER LEVEL OBSERVATIONS**

Groundwater not encountered

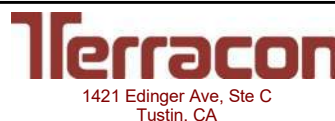

Boring Started: 02-12-2019

Boring Completed: 02-12-2019

Drill Rig: CME 75

Driller: Martini

Project No.: 60185184

Exhibit: A-6

THIS BORING LOG IS NOT VALID IF SEPARATED FROM ORIGINAL REPORT. GEO SMART LOG-NO WELL\_60185184 BORING LOGS.GPJ MODEL LAYER.GPJ 3/6/19

# BORING LOG NO. PA-1

**PROJECT:** SGVCOG ACE Rio Hondo Load Reduction Strategy Design Project

**CLIENT:** CWE Corp  
Fullerton, CA

**SITE:** Alhambra Wash, Eaton Wash, Rubio Wash  
San Gabriel Valley, Los Angeles County, CA

GRAPHIC LOG	LOCATION See Exhibit A-2 Latitude: 34.0513° Longitude: -118.0832°	DEPTH (Ft.)	WATER LEVEL OBSERVATIONS	SAMPLE TYPE	FIELD TEST RESULTS	STRENGTH TEST			WATER CONTENT (%)	DRY UNIT WEIGHT (pcf)	ATTERBERG LIMITS	PERCENT FINES
						TEST TYPE	COMPRESSIVE STRENGTH (tsf)	STRAIN (%)			LL-PL-PI	
DEPTH												
	Drilled to 20 feet and did not collect samples											
		5										
		10										
		15										
		20		X	0-2-3 N=5							47
		23.5										
		25		X	3-6-10 N=16							67
	<b>Boring Terminated at 25 Feet</b>											

Stratification lines are approximate. In-situ, the transition may be gradual.

Hammer Type: Automatic

Advancement Method:  
Hollow-stem auger

See Exhibit A-3 for description of field procedures.  
See Appendix B for description of laboratory procedures and additional data (if any).  
See Appendix C for explanation of symbols and abbreviations.

Notes:

Abandonment Method:  
Boring backfilled with cement-bentonite grout upon completion.

**WATER LEVEL OBSERVATIONS**

*Groundwater not encountered*

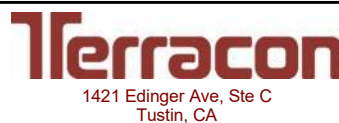

Boring Started: 02-12-2019

Boring Completed: 02-13-2019

Drill Rig: CME 75

Driller: Martini

Project No.: 60185184

Exhibit: A-7

THIS BORING LOG IS NOT VALID IF SEPARATED FROM ORIGINAL REPORT. GEO SMART LOG-NO WELL\_ 60185184 BORING LOGS.GPJ\_MODEL LAYER.GPJ 3/6/19

# BORING LOG NO. BE-1

**PROJECT:** SGVCOG ACE Rio Hondo Load Reduction Strategy Design Project

**CLIENT:** CWE Corp  
Fullerton, CA

**SITE:** Alhambra Wash, Eaton Wash, Rubio Wash  
San Gabriel Valley, Los Angeles County, CA

GRAPHIC LOG	LOCATION See Exhibit A-2 Latitude: 34.07319° Longitude: -118.05549°	DEPTH (Ft.)	WATER LEVEL OBSERVATIONS	SAMPLE TYPE	FIELD TEST RESULTS	STRENGTH TEST			WATER CONTENT (%)	DRY UNIT WEIGHT (pcf)	ATTERBERG LIMITS	
						TEST TYPE	COMPRESSIVE STRENGTH (tsf)	STRAIN (%)			LL-PL-PI	PERCENT FINES
DEPTH												
	<b>SILTY SAND (SM)</b> , brown, loose	5		X	1-4-3 N=7							
	<b>SILT WITH SAND (ML)</b> , olive brown, medium stiff	7.5		X	2-3-4 N=7							72
	stiff	10		X	3-4-6 N=10							
	medium stiff	15		X	0-4-5 N=9							71
		20		X	1-2-4 N=6							
		25		X	1-2-4 N=6							48
		25.0										
	<b>SILTY SAND (SM)</b> , brown, loose			X	1-2-4 N=6							

Stratification lines are approximate. In-situ, the transition may be gradual.

Hammer Type: Automatic

Advancement Method:  
Hollow-stem auger

See Exhibit A-3 for description of field procedures.  
See Appendix B for description of laboratory procedures and additional data (if any).  
See Appendix C for explanation of symbols and abbreviations.

Notes:

Abandonment Method:  
Boring backfilled with cement-bentonite grout upon completion.

**WATER LEVEL OBSERVATIONS**

*Groundwater not encountered*

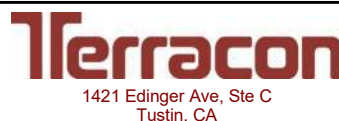

Boring Started: 02-13-2019

Boring Completed: 02-13-2019

Drill Rig: CME 75

Driller: Martini

Project No.: 60185184

Exhibit: A-8

THIS BORING LOG IS NOT VALID IF SEPARATED FROM ORIGINAL REPORT. GEO SMART LOG-NO WELL\_60185184 BORING LOGS.GPJ MODEL LAYER.GPJ 3/6/19

# BORING LOG NO. BE-1

**PROJECT:** SGVCOG ACE Rio Hondo Load Reduction Strategy Design Project

**CLIENT:** CWE Corp  
Fullerton, CA

**SITE:** Alhambra Wash, Eaton Wash, Rubio Wash  
San Gabriel Valley, Los Angeles County, CA

GRAPHIC LOG	LOCATION See Exhibit A-2 Latitude: 34.07319° Longitude: -118.05549°	DEPTH (Ft.)	WATER LEVEL OBSERVATIONS	SAMPLE TYPE	FIELD TEST RESULTS	STRENGTH TEST			WATER CONTENT (%)	DRY UNIT WEIGHT (pcf)	ATTERBERG LIMITS	PERCENT FINES
						TEST TYPE	COMPRESSIVE STRENGTH (tsf)	STRAIN (%)			LL-PL-PI	
DEPTH												
30	<b>SILTY SAND (SM)</b> , brown, loose <i>(continued)</i>	30		X	3-9-13 N=22							40
35	<b>POORLY GRADED SAND (SP)</b> , trace gravel, olive brown, dense, trace silt	35		X	9-13-16 N=29							5
40		40		X	9-16-17 N=33							
45	<b>SILTY SAND (SM)</b> , medium dense brown to black	45		X	10-12-9 N=21							32
50	dark brown to brown	50		X	8-14-12 N=26							
51.5	<b>Boring Terminated at 51.5 Feet</b>											

Stratification lines are approximate. In-situ, the transition may be gradual.

Hammer Type: Automatic

Advancement Method:  
Hollow-stem auger

See Exhibit A-3 for description of field procedures.  
See Appendix B for description of laboratory procedures and additional data (if any).

Notes:

Abandonment Method:  
Boring backfilled with cement-bentonite grout upon completion.

See Appendix C for explanation of symbols and abbreviations.

**WATER LEVEL OBSERVATIONS**

Groundwater not encountered

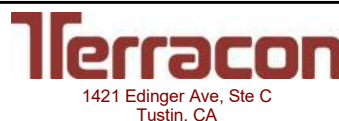

Boring Started: 02-13-2019

Boring Completed: 02-13-2019

Drill Rig: CME 75

Driller: Martini

Project No.: 60185184

Exhibit: A-8

THIS BORING LOG IS NOT VALID IF SEPARATED FROM ORIGINAL REPORT. GEO SMART LOG-NO WELL\_60185184 BORING LOGS.GPJ MODELAYER.GPJ 3/6/19

# BORING LOG NO. BE-2

**PROJECT:** SGVCOG ACE Rio Hondo Load Reduction Strategy Design Project

**CLIENT:** CWE Corp  
Fullerton, CA

**SITE:** Alhambra Wash, Eaton Wash, Rubio Wash  
San Gabriel Valley, Los Angeles County, CA

GRAPHIC LOG	LOCATION See Exhibit A-2 Latitude: 34.07297° Longitude: -118.05552°	DEPTH (Ft.)	WATER LEVEL OBSERVATIONS	SAMPLE TYPE	FIELD TEST RESULTS	STRENGTH TEST			WATER CONTENT (%)	DRY UNIT WEIGHT (pcf)	ATTERBERG LIMITS		PERCENT FINES
						TEST TYPE	COMPRESSIVE STRENGTH (tsf)	STRAIN (%)			LL-PL-PI		
DEPTH													
	<b>SILTY SAND (SM)</b> , brown, loose	5		X	3-3-6			8	82				
		10		X	1-2-3 N=5								
		15		X	4-5-7			6	102			21	
		20		X	3-8-14			19	137				
		25		X	1-2-4 N=6								
	<b>Boring Terminated at 26.5 Feet</b>												

Stratification lines are approximate. In-situ, the transition may be gradual.

Hammer Type: Automatic

Advancement Method:  
Hollow-stem auger

See Exhibit A-3 for description of field procedures.  
See Appendix B for description of laboratory procedures and additional data (if any).  
See Appendix C for explanation of symbols and abbreviations.

Notes:

Abandonment Method:  
Boring backfilled with cement-bentonite grout upon completion.

**WATER LEVEL OBSERVATIONS**

Groundwater not encountered

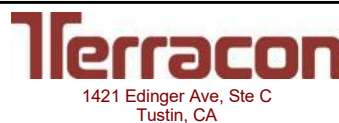

Boring Started: 02-13-2019

Boring Completed: 02-13-2019

Drill Rig: CME 75

Driller: Martini

Project No.: 60185184

Exhibit: A-9

THIS BORING LOG IS NOT VALID IF SEPARATED FROM ORIGINAL REPORT. GEO SMART LOG-NO WELL\_60185184 BORING LOGS.GPJ MODEL LAYER.GPJ 3/6/19

# BORING LOG NO. PE-1

**PROJECT: SGVCOG ACE Rio Hondo Load Reduction Strategy Design Project**

**CLIENT: CWE Corp  
Fullerton, CA**

**SITE: Alhambra Wash, Eaton Wash, Rubio Wash  
San Gabriel Valley, Los Angeles County, CA**

GRAPHIC LOG	LOCATION See Exhibit A-2 Latitude: 34.07322° Longitude: -118.05549°	DEPTH (Ft.)	WATER LEVEL OBSERVATIONS	SAMPLE TYPE	FIELD TEST RESULTS	STRENGTH TEST			WATER CONTENT (%)	DRY UNIT WEIGHT (pcf)	ATTERBERG LIMITS	PERCENT FINES
						TEST TYPE	COMPRESSIVE STRENGTH (tsf)	STRAIN (%)			LL-PL-PI	
DEPTH												
	Drilled to 20 feet and did not collect samples											
		5										
		10										
		15										
		20		X	1-2-4 N=6							69
		23.5										
		25		X	1-2-3 N=5							48
	<b>Boring Terminated at 25 Feet</b>	25										

Stratification lines are approximate. In-situ, the transition may be gradual.

Hammer Type: Automatic

Advancement Method:  
Hollow-stem auger

See Exhibit A-3 for description of field procedures.  
See Appendix B for description of laboratory procedures and additional data (if any).  
See Appendix C for explanation of symbols and abbreviations.

Notes:

Abandonment Method:  
Boring backfilled with cement-bentonite grout upon completion.

**WATER LEVEL OBSERVATIONS**

Groundwater not encountered

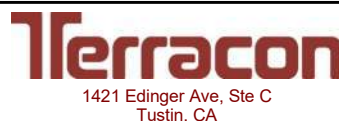

Boring Started: 02-13-2019

Boring Completed: 02-14-2019

Drill Rig: CME 75

Driller: Martini

Project No.: 60185184

Exhibit: A-10

THIS BORING LOG IS NOT VALID IF SEPARATED FROM ORIGINAL REPORT. GEO SMART LOG-NO WELL\_60185184 BORING LOGS.GPJ MODELLAYER.GPJ 3/6/19

# BORING LOG NO. BR-1

**PROJECT: SGVCOG ACE Rio Hondo Load Reduction Strategy Design Project**

**CLIENT: CWE Corp  
Fullerton, CA**

**SITE: Alhambra Wash, Eaton Wash, Rubio Wash  
San Gabriel Valley, Los Angeles County, CA**

GRAPHIC LOG	LOCATION See Exhibit A-2 Latitude: 34.065° Longitude: -118.0678°	DEPTH (Ft.)	WATER LEVEL OBSERVATIONS	SAMPLE TYPE	FIELD TEST RESULTS	STRENGTH TEST			WATER CONTENT (%)	DRY UNIT WEIGHT (pcf)	ATTERBERG LIMITS	
						TEST TYPE	COMPRESSIVE STRENGTH (tsf)	STRAIN (%)			LL-PL-PI	PERCENT FINES
DEPTH												
12.0	<b>FILL - SILTY SAND (SM)</b> , dark brown, very loose	5		X	2-2-1 N=3							
	loose	10		X	0-0-1 N=1							42
		12.0		X	0-2-5 N=7							29
25.0	<b>POORLY GRADED SAND WITH SILT (SP-SM)</b> , gray, loose	15		X	2-4-4 N=8							
	medium dense	20		X	3-6-6 N=12							6
25.0	<b>SILTY CLAY WITH SAND (CL-ML)</b> , dark brown, soft	25		X	0-0-2 N=2							82

Stratification lines are approximate. In-situ, the transition may be gradual.

Hammer Type: Automatic

Advancement Method:  
Hollow-stem auger

See Exhibit A-3 for description of field procedures.  
See Appendix B for description of laboratory procedures and additional data (if any).

Notes:

Abandonment Method:  
Boring backfilled with cement-bentonite grout upon completion.

See Appendix C for explanation of symbols and abbreviations.

**WATER LEVEL OBSERVATIONS**

Groundwater not encountered

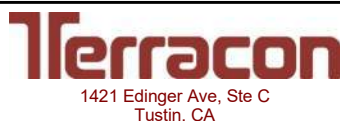

Boring Started: 02-12-2019

Boring Completed: 02-12-2019

Drill Rig: CME 75

Driller: Martini

Project No.: 60185184

Exhibit: A-11

THIS BORING LOG IS NOT VALID IF SEPARATED FROM ORIGINAL REPORT. GEO SMART LOG-NO WELL\_60185184 BORING LOGS.GPJ MODELAYER.GPJ 3/6/19

# BORING LOG NO. BR-1

**PROJECT:** SGVCOG ACE Rio Hondo Load Reduction Strategy Design Project

**CLIENT:** CWE Corp  
Fullerton, CA

**SITE:** Alhambra Wash, Eaton Wash, Rubio Wash  
San Gabriel Valley, Los Angeles County, CA

GRAPHIC LOG	LOCATION See Exhibit A-2 Latitude: 34.065° Longitude: -118.0678°	DEPTH (Ft.)	WATER LEVEL OBSERVATIONS	SAMPLE TYPE	FIELD TEST RESULTS	STRENGTH TEST			WATER CONTENT (%)	DRY UNIT WEIGHT (pcf)	ATTERBERG LIMITS	PERCENT FINES
						TEST TYPE	COMPRESSIVE STRENGTH (tsf)	STRAIN (%)			LL-PL-PI	
	<b>SILTY CLAY WITH SAND (CL-ML)</b> , dark brown, soft <i>(continued)</i>	30.0										
	<b>SANDY SILTY CLAY (CL-ML)</b> , brown, soft to medium stiff	30		X	1-1-3 N=4							
	<b>CLAYEY SAND (SC)</b> , brown, medium dense	35.0		X	3-6-9 N=15							34
	<b>SILTY SAND WITH GRAVEL (SM)</b> , olive brown, medium dense	40.0		X	7-10-9 N=19							26
	<b>SILTY SAND (SM)</b> , brown, medium dense	45.0		X	2-5-10 N=15							40
	<b>Boring Terminated at 51.5 Feet</b>	50		X	4-8-9 N=17							

Stratification lines are approximate. In-situ, the transition may be gradual.

Hammer Type: Automatic

Advancement Method:  
Hollow-stem auger

See Exhibit A-3 for description of field procedures.  
See Appendix B for description of laboratory procedures and additional data (if any).  
See Appendix C for explanation of symbols and abbreviations.

Notes:

Abandonment Method:  
Boring backfilled with cement-bentonite grout upon completion.

**WATER LEVEL OBSERVATIONS**

Groundwater not encountered

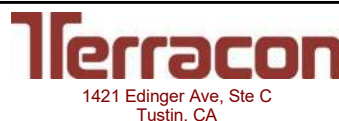

Boring Started: 02-12-2019

Boring Completed: 02-12-2019

Drill Rig: CME 75

Driller: Martini

Project No.: 60185184

Exhibit: A-11

THIS BORING LOG IS NOT VALID IF SEPARATED FROM ORIGINAL REPORT. GEO SMART LOG-NO WELL. 60185184 BORING LOGS.GPJ MODEL LAYER.GPJ 3/6/19



# BORING LOG NO. BR-2

**PROJECT: SGVCOG ACE Rio Hondo Load Reduction Strategy Design Project**

**CLIENT: CWE Corp  
Fullerton, CA**

**SITE: Alhambra Wash, Eaton Wash, Rubio Wash  
San Gabriel Valley, Los Angeles County, CA**

GRAPHIC LOG	LOCATION See Exhibit A-2 Latitude: 34.0646° Longitude: -118.0674°	DEPTH (Ft.)	WATER LEVEL OBSERVATIONS	SAMPLE TYPE	FIELD TEST RESULTS	STRENGTH TEST			WATER CONTENT (%)	DRY UNIT WEIGHT (pcf)	ATTERBERG LIMITS		PERCENT FINES
						TEST TYPE	COMPRESSIVE STRENGTH (tsf)	STRAIN (%)			LL-PL-PI		
DEPTH	<p><b>FILL - SILTY CLAYEY SAND (SC-SM)</b>, dark brown, medium dense</p> <p>samples placed in bag because of a piece of wood in sample, odor</p>	5		X	14-18-32								
		7.5		X	2-50/6"								
		10	<p><b>FILL - CLAYEY SAND WITH GRAVEL (SC)</b>, dark brown, very dense, asphalt chunks, odor</p> <p>medium dense</p>		X	10-8-12			16	98			26
		15.0	<p><b>SILTY SAND (SM)</b>, grayish brown, medium dense, mica</p>		X	5-6-5 N=11							
		20.0	<p><b>POORLY GRADED SAND (SP)</b>, light grey medium dense</p> <p>dense</p>	25		X	11-21-29			5	113		5
	<b>Boring Terminated at 26.5 Feet</b>												

Stratification lines are approximate. In-situ, the transition may be gradual.

Hammer Type: Automatic

Advancement Method:  
Hollow-stem auger

See Exhibit A-3 for description of field procedures.  
See Appendix B for description of laboratory procedures and additional data (if any).

Notes:

Abandonment Method:  
Boring backfilled with cement-bentonite grout upon completion.

See Appendix C for explanation of symbols and abbreviations.

**WATER LEVEL OBSERVATIONS**

Groundwater not encountered

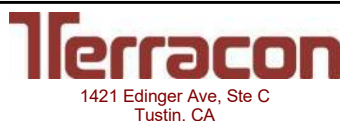

Boring Started: 02-12-2019

Boring Completed: 02-12-2019

Drill Rig: CME 75

Driller: Martini

Project No.: 60185184

Exhibit: A-12

THIS BORING LOG IS NOT VALID IF SEPARATED FROM ORIGINAL REPORT. GEO SMART LOG-NO WELL\_60185184 BORING LOGS.GPJ MODEL LAYER.GPJ 3/6/19

# BORING LOG NO. PR-1

**PROJECT: SGVCOG ACE Rio Hondo Load Reduction Strategy Design Project**

**CLIENT: CWE Corp  
Fullerton, CA**

**SITE: Alhambra Wash, Eaton Wash, Rubio Wash  
San Gabriel Valley, Los Angeles County, CA**

GRAPHIC LOG	LOCATION See Exhibit A-2 Latitude: 34.0651° Longitude: -118.0679°	DEPTH (Ft.)	WATER LEVEL OBSERVATIONS	SAMPLE TYPE	FIELD TEST RESULTS	STRENGTH TEST			WATER CONTENT (%)	DRY UNIT WEIGHT (pcf)	ATTERBERG LIMITS	PERCENT FINES
						TEST TYPE	COMPRESSIVE STRENGTH (tsf)	STRAIN (%)			LL-PL-PI	
DEPTH												
	Drilled to 20 feet and did not collect samples											
		5										
		10										
		15										
		20		X	2-3-2 N=5						26-20-6	16
		25		X	0-0-2 N=2							82
		26.5										

Stratification lines are approximate. In-situ, the transition may be gradual.

Hammer Type: Automatic

Advancement Method:  
Hollow-stem auger

See Exhibit A-3 for description of field procedures.  
See Appendix B for description of laboratory procedures and additional data (if any).

Notes:

Abandonment Method:  
Boring backfilled with cement-bentonite grout upon completion.

See Appendix C for explanation of symbols and abbreviations.

**WATER LEVEL OBSERVATIONS**  
*Groundwater not encountered*

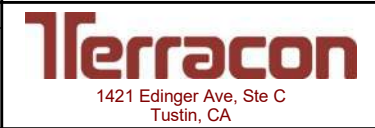

Boring Started: 02-12-2019  
Drill Rig: CME 75  
Project No.: 60185184

Boring Completed: 02-13-2019  
Driller: Martini  
Exhibit: A-13

THIS BORING LOG IS NOT VALID IF SEPARATED FROM ORIGINAL REPORT. GEO SMART LOG-NO WELL\_60185184 BORING LOGS.GPJ MODELLAYER.GPJ 3/6/19

**APPENDIX B**  
**LABORATORY TESTING**



## DIRECT SHEAR TEST ASTM D3080

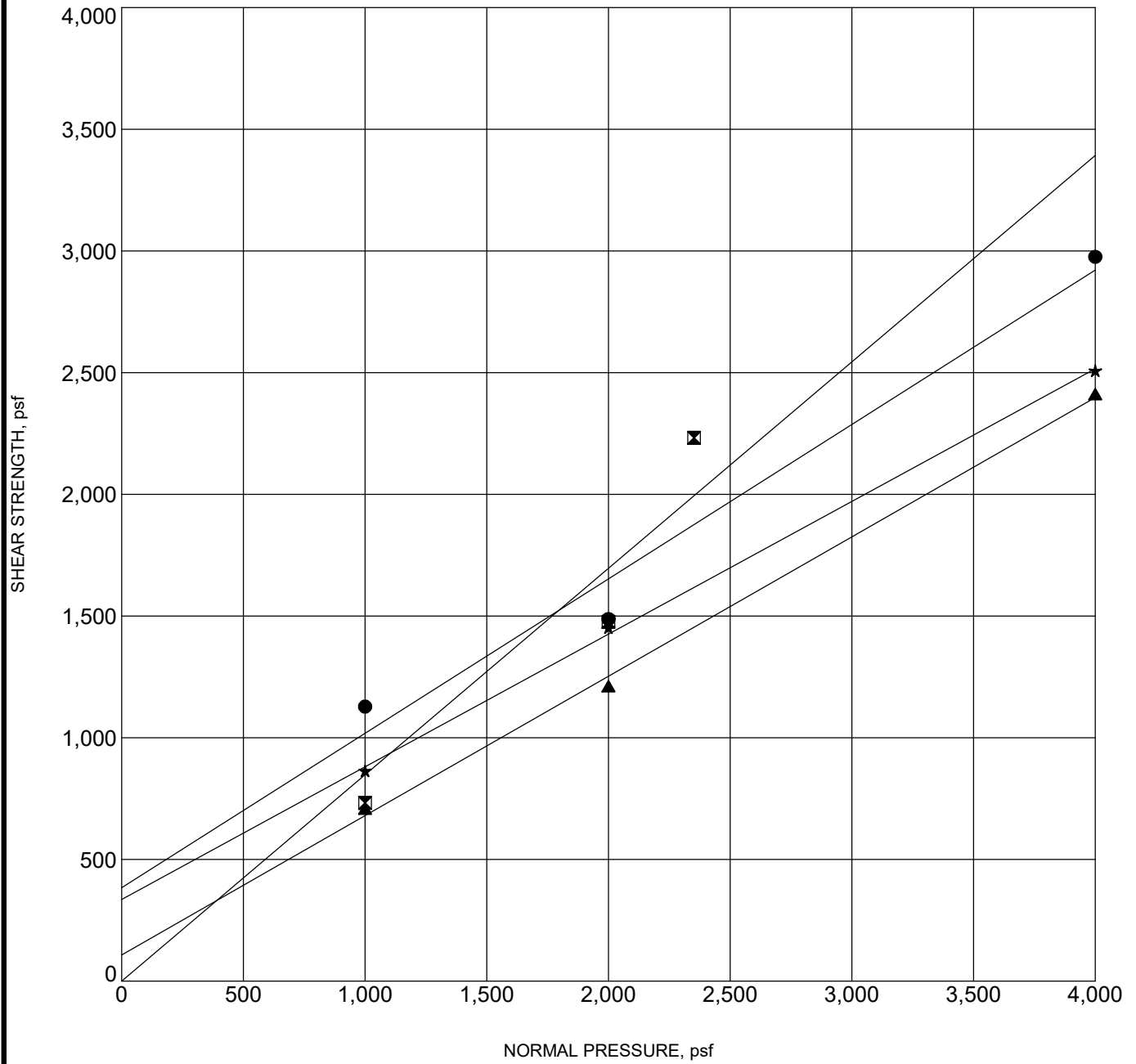

Specimen Identification	Classification	$\gamma_d$ , pcf	WC, %	c, psf	$\phi^\circ$
● BA-2 10 - 11.5	SILTY SAND (SM)	120	15	384	32
⊠ BA-3 8.5 - 10	CLAYEY SAND (SC)	108	10	0	40
▲ BE-2 10 - 11.5	SILTY SAND (SM)	102	6	108	30
★ BR-2 10 - 11.5	FILL: CLAYEY SAND WITH GRAVEL (SC)	98	16	336	29

PROJECT: SGVCOG ACE Rio Hondo Load Reduction Strategy Design  
 SITE: Alhambra Wash, Eaton Wash, Rubio Wash  
 San Gabriel Valley, Los Angeles County, CA



PROJECT NUMBER: 60185184

CLIENT: CWE Corp  
 Fullerton, CA

EXHIBIT: B-2

LABORATORY TESTS ARE NOT VALID IF SEPARATED FROM ORIGINAL REPORT. TC\_DIRECT\_SHEAR\_60185184 BORING LOGS.GPJ TERRACON\_DATATEMPLATE.GDT 3/4/19

# CHEMICAL LABORATORY TEST REPORT

**Project Number:** 60185184

**Service Date:** 02/28/19

**Report Date:** 03/04/19

**Task:**

# Terracon

750 Pilot Road, Suite F  
Las Vegas, Nevada 89119  
(702) 597-9393

---

## Client

CWE Corp

## Project

CWE: SGVCOG ACE Rio Hondo Load Reduction Strategy Design

**Sample Submitted By:** Terracon (60)

**Date Received:** 2/27/2019

**Lab No.:** 19-0234

## *Results of Corrosion Analysis*

<i>Sample Number</i>			
<i>Sample Location</i>	BA-1	BE-1	BR-1
<i>Sample Depth (ft.)</i>	0.0-5.0	0.0-5.0	0.0-5.0
pH Analysis, AWWA 4500 H	8.28	8.37	8.56
Water Soluble Sulfate (SO <sub>4</sub> ), AWWA 4500 E (percent %)	0.01	0.01	0.01
Sulfides, AWWA 4500-S D, (mg/kg)	Nil	Nil	Nil
Chlorides, ASTM D 512, (mg/kg)	42	43	53
Red-Ox, AWWA 2580, (mV)	+683	+677	+677
Total Salts, AWWA 2520 B, (mg/kg)	1238	657	577
Resistivity, ASTM G 57, (ohm-cm)	1455	3589	3783

---

**Analyzed By:**















Trisha Campo  
Chemist

The tests were performed in general accordance with applicable ASTM, AASHTO, or DOT test methods. This report is exclusively for the use of the client indicated above and shall not be reproduced except in full without the written consent of our company. Test results transmitted herein are only applicable to the actual samples tested at the location(s) referenced and are not necessarily indicative of the properties of other apparently similar or identical materials.

**APPENDIX C**  
**SUPPORTING DOCUMENTS**

# GENERAL NOTES

## DESCRIPTION OF SYMBOLS AND ABBREVIATIONS

<b>SAMPLING</b>				<b>WATER LEVEL</b>		Water Initially Encountered	<b>FIELD TESTS</b>	(HP) Hand Penetrometer
						Water Level After a Specified Period of Time		(T) Torvane
						Water Level After a Specified Period of Time		(b/f) Standard Penetration Test (blows per foot)
	<p>Water levels indicated on the soil boring logs are the levels measured in the borehole at the times indicated. Groundwater level variations will occur over time. In low permeability soils, accurate determination of groundwater levels is not possible with short term water level observations.</p>						N N value	
								(PID) Photo-Ionization Detector
								(OVA) Organic Vapor Analyzer

## DESCRIPTIVE SOIL CLASSIFICATION

Soil classification is based on the Unified Soil Classification System. Coarse Grained Soils have more than 50% of their dry weight retained on a #200 sieve; their principal descriptors are: boulders, cobbles, gravel or sand. Fine Grained Soils have less than 50% of their dry weight retained on a #200 sieve; they are principally described as clays if they are plastic, and silts if they are slightly plastic or non-plastic. Major constituents may be added as modifiers and minor constituents may be added according to the relative proportions based on grain size. In addition to gradation, coarse-grained soils are defined on the basis of their in-place relative density and fine-grained soils on the basis of their consistency.

## LOCATION AND ELEVATION NOTES

Unless otherwise noted, Latitude and Longitude are approximately determined using a hand-held GPS device. The accuracy of such devices is variable. Surface elevation data annotated with +/- indicates that no actual topographical survey was conducted to confirm the surface elevation. Instead, the surface elevation was approximately determined from topographic maps of the area.

<b>STRENGTH TERMS</b>	<b>RELATIVE DENSITY OF COARSE-GRAINED SOILS</b> (More than 50% retained on No. 200 sieve.) Density determined by Standard Penetration Resistance Includes gravels and sands.			<b>CONSISTENCY OF FINE-GRAINED SOILS</b> (50% or more passing the No. 200 sieve.) Consistency determined by laboratory shear strength testing, field visual-manual procedures or standard penetration resistance Includes silts and clays.			
	Descriptive Term (Density)	Standard Penetration or N-Value Blows/Ft.	Ring Sampler Blows/Ft.	Descriptive Term (Consistency)	Unconfined Compressive Strength, Qu, psf	Standard Penetration or N-Value Blows/Ft.	Ring Sampler Blows/Ft.
Very Loose	0 - 3	0 - 6	Very Soft	less than 500	0 - 1	< 3	
Loose	4 - 9	7 - 18	Soft	500 to 1,000	2 - 4	3 - 4	
Medium Dense	10 - 29	19 - 58	Medium-Stiff	1,000 to 2,000	4 - 8	5 - 9	
Dense	30 - 50	59 - 98	Stiff	2,000 to 4,000	8 - 15	10 - 18	
Very Dense	> 50	≥ 99	Very Stiff	4,000 to 8,000	15 - 30	19 - 42	
			Hard	> 8,000	> 30	> 42	

## RELATIVE PROPORTIONS OF SAND AND GRAVEL

<u>Descriptive Term(s) of other constituents</u>	<u>Percent of Dry Weight</u>
Trace	< 15
With	15 - 29
Modifier	> 30

## RELATIVE PROPORTIONS OF FINES

<u>Descriptive Term(s) of other constituents</u>	<u>Percent of Dry Weight</u>
Trace	< 5
With	5 - 12
Modifier	> 12

## GRAIN SIZE TERMINOLOGY

<u>Major Component of Sample</u>	<u>Particle Size</u>
Boulders	Over 12 in. (300 mm)
Cobbles	12 in. to 3 in. (300mm to 75mm)
Gravel	3 in. to #4 sieve (75mm to 4.75 mm)
Sand	#4 to #200 sieve (4.75mm to 0.075mm)
Silt or Clay	Passing #200 sieve (0.075mm)

## PLASTICITY DESCRIPTION

<u>Term</u>	<u>Plasticity Index</u>
Non-plastic	0
Low	1 - 10
Medium	11 - 30
High	> 30



# UNIFIED SOIL CLASSIFICATION SYSTEM

Criteria for Assigning Group Symbols and Group Names Using Laboratory Tests <sup>A</sup>				Soil Classification		
				Group Symbol	Group Name <sup>B</sup>	
<b>Coarse Grained Soils:</b> More than 50% retained on No. 200 sieve	<b>Gravels:</b> More than 50% of coarse fraction retained on No. 4 sieve	<b>Clean Gravels:</b> Less than 5% fines <sup>C</sup>	$Cu \geq 4$ and $1 \leq Cc \leq 3$ <sup>E</sup>	GW	Well-graded gravel <sup>F</sup>	
			$Cu < 4$ and/or $1 > Cc > 3$ <sup>E</sup>	GP	Poorly graded gravel <sup>F</sup>	
		<b>Gravels with Fines:</b> More than 12% fines <sup>C</sup>	Fines classify as ML or MH	GM	Silty gravel <sup>F,G,H</sup>	
			Fines classify as CL or CH	GC	Clayey gravel <sup>F,G,H</sup>	
	<b>Sands:</b> 50% or more of coarse fraction passes No. 4 sieve	<b>Clean Sands:</b> Less than 5% fines <sup>D</sup>	$Cu \geq 6$ and $1 \leq Cc \leq 3$ <sup>E</sup>	SW	Well-graded sand <sup>I</sup>	
			$Cu < 6$ and/or $1 > Cc > 3$ <sup>E</sup>	SP	Poorly graded sand <sup>I</sup>	
		<b>Sands with Fines:</b> More than 12% fines <sup>D</sup>	Fines classify as ML or MH	SM	Silty sand <sup>G,H,I</sup>	
			Fines classify as CL or CH	SC	Clayey sand <sup>G,H,I</sup>	
<b>Fine-Grained Soils:</b> 50% or more passes the No. 200 sieve	<b>Silts and Clays:</b> Liquid limit less than 50	<b>Inorganic:</b>	$PI > 7$ and plots on or above "A" line <sup>J</sup>	CL	Lean clay <sup>K,L,M</sup>	
			$PI < 4$ or plots below "A" line <sup>J</sup>	ML	Silt <sup>K,L,M</sup>	
		<b>Organic:</b>	Liquid limit - oven dried	< 0.75	OL	Organic clay <sup>K,L,M,N</sup>
			Liquid limit - not dried		OH	Organic silt <sup>K,L,M,O</sup>
	<b>Silts and Clays:</b> Liquid limit 50 or more	<b>Inorganic:</b>	$PI$ plots on or above "A" line	CH	Fat clay <sup>K,L,M</sup>	
			$PI$ plots below "A" line	MH	Elastic Silt <sup>K,L,M</sup>	
		<b>Organic:</b>	Liquid limit - oven dried	< 0.75	OH	Organic clay <sup>K,L,M,P</sup>
			Liquid limit - not dried		OH	Organic silt <sup>K,L,M,Q</sup>
	<b>Highly organic soils:</b>	Primarily organic matter, dark in color, and organic odor			PT	Peat

<sup>A</sup> Based on the material passing the 3-inch (75-mm) sieve

<sup>B</sup> If field sample contained cobbles or boulders, or both, add "with cobbles or boulders, or both" to group name.

<sup>C</sup> Gravels with 5 to 12% fines require dual symbols: GW-GM well-graded gravel with silt, GW-GC well-graded gravel with clay, GP-GM poorly graded gravel with silt, GP-GC poorly graded gravel with clay.

<sup>D</sup> Sands with 5 to 12% fines require dual symbols: SW-SM well-graded sand with silt, SW-SC well-graded sand with clay, SP-SM poorly graded sand with silt, SP-SC poorly graded sand with clay

$$E \quad Cu = D_{60}/D_{10} \quad Cc = \frac{(D_{30})^2}{D_{10} \times D_{60}}$$

<sup>F</sup> If soil contains  $\geq 15\%$  sand, add "with sand" to group name.

<sup>G</sup> If fines classify as CL-ML, use dual symbol GC-GM, or SC-SM.

<sup>H</sup> If fines are organic, add "with organic fines" to group name.

<sup>I</sup> If soil contains  $\geq 15\%$  gravel, add "with gravel" to group name.

<sup>J</sup> If Atterberg limits plot in shaded area, soil is a CL-ML, silty clay.

<sup>K</sup> If soil contains 15 to 29% plus No. 200, add "with sand" or "with gravel," whichever is predominant.

<sup>L</sup> If soil contains  $\geq 30\%$  plus No. 200 predominantly sand, add "sandy" to group name.

<sup>M</sup> If soil contains  $\geq 30\%$  plus No. 200, predominantly gravel, add "gravelly" to group name.

<sup>N</sup>  $PI \geq 4$  and plots on or above "A" line.

<sup>O</sup>  $PI < 4$  or plots below "A" line.

<sup>P</sup>  $PI$  plots on or above "A" line.

<sup>Q</sup>  $PI$  plots below "A" line.

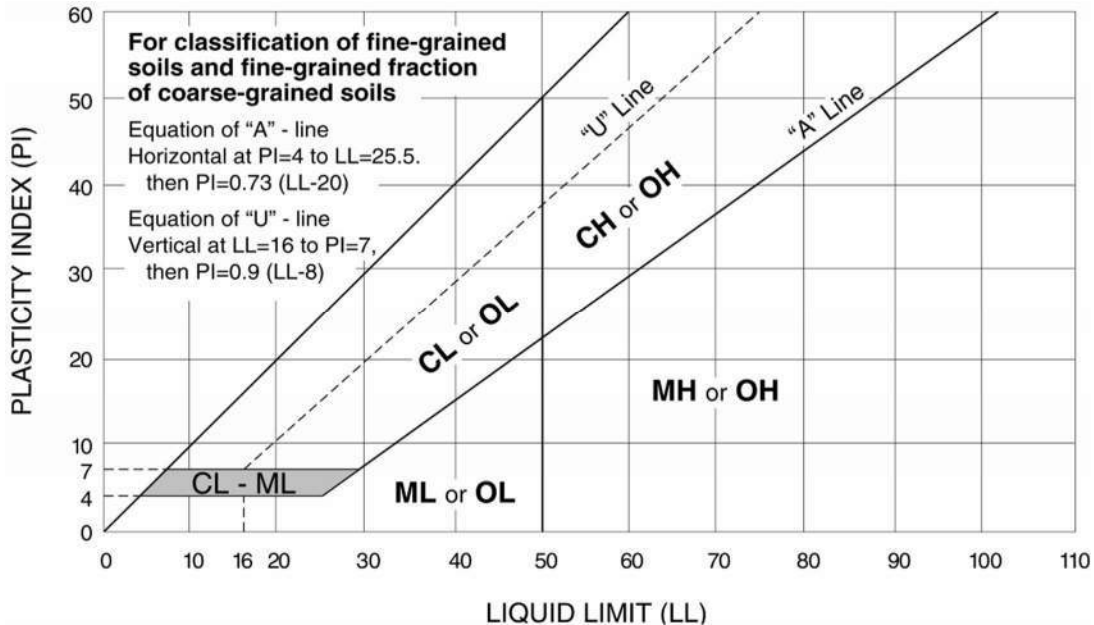

**APPENDIX D**  
**LIQUEFACTION ANALYSIS**

# LIQUEFACTION ANALYSIS

## Alhambra Wash

Hole No.=BA-1 Water Depth=50 ft

Magnitude=6.87  
Acceleration=0.93g

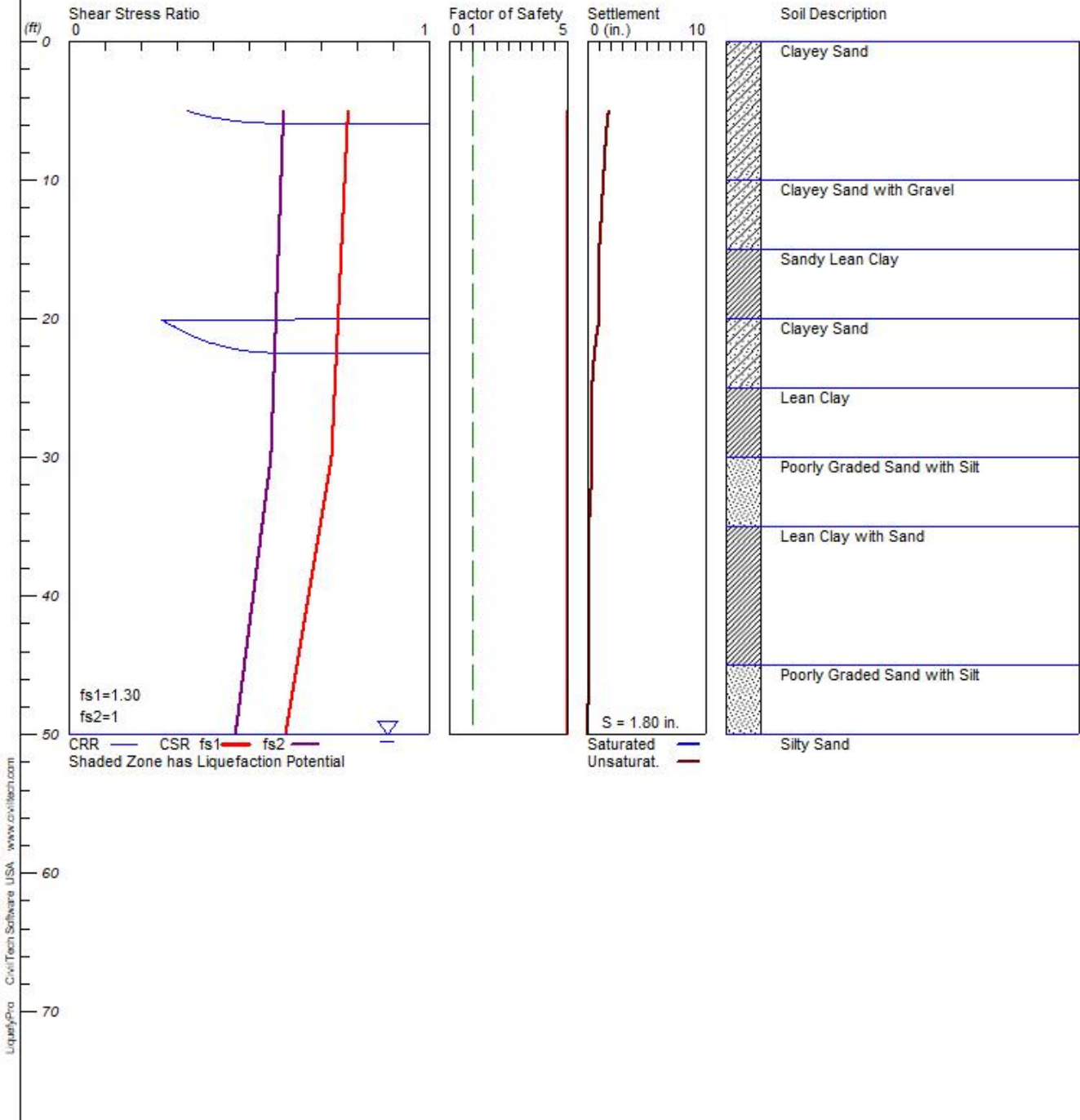

\*\*\*\*\*  
\*\*\*\*\*

LIQUEFACTION ANALYSIS SUMMARY

Copyright by CivilTech Software  
www.civilttechsoftware.com

\*\*\*\*\*  
\*\*\*\*\*

Font: Courier New, Regular, Size 8 is recommended for this report.  
Licensed to , 3/5/2019 2:44:54 PM

Input File Name: N:\Projects\2018\60185184\Working  
Files\Calculations-Analyses\BA-1. liq  
Title: Alhambra Wash  
Subtitle: SGVCOG ACE Rio Hondo Load Reduction Strategy Design Project

Surface Elev. =  
Hole No. =BA-1  
Depth of Hole= 50.00 ft  
Water Table during Earthquake= 50.00 ft  
Water Table during In-Situ Testing= 50.00 ft  
Max. Acceleration= 0.93 g  
Earthquake Magnitude= 6.87

Input Data:

Surface Elev. =  
Hole No. =BA-1  
Depth of Hole=50.00 ft  
Water Table during Earthquake= 50.00 ft  
Water Table during In-Situ Testing= 50.00 ft  
Max. Acceleration=0.93 g  
Earthquake Magnitude=6.87  
No-Liquefiable Soils: CL, OL are Non-Liq. Soil

1. SPT or BPT Calculation.
  2. Settlement Analysis Method: Tokimatsu, M-correction
  3. Fines Correction for Liquefaction: Modify Stark/Olson
  4. Fine Correction for Settlement: During Liquefaction\*
  5. Settlement Calculation in: All zones\*
  6. Hammer Energy Ratio, Ce = 1.4
  7. Borehole Diameter, Cb= 1.15
  8. Sampling Method, Cs= 1.2
  9. User request factor of safety (apply to CSR) , User= 1.3  
Plot two CSR (fs1=User, fs2=1)
  10. Use Curve Smoothing: Yes\*
- \* Recommended Options

BA-1. sum

In-Situ Test Data:

Depth ft	SPT	gamma pcf	Fines %
5.00	8.00	100.00	22.00
7.50	15.00	100.00	22.00
10.00	16.00	100.00	22.00
15.00	7.00	120.00	NoLi q
20.00	5.00	100.00	45.00
25.00	11.00	120.00	NoLi q
30.00	43.00	100.00	7.00
35.00	12.00	120.00	NoLi q
40.00	9.00	120.00	NoLi q
45.00	37.00	100.00	7.00
50.00	35.00	100.00	22.00

Output Results:

Settlement of Saturated Sands=0.00 in.  
 Settlement of Unsaturated Sands=1.80 in.  
 Total Settlement of Saturated and Unsaturated Sands=1.80 in.  
 Differential Settlement=0.902 to 1.190 in.

Depth ft	CRRm	CSRfs	F. S.	S_sat. in.	S_dry in.	S_all in.
5.00	0.33	0.78	5.00	0.00	1.80	1.80
6.00	2.50	0.77	5.00	0.00	1.66	1.66
7.00	2.50	0.77	5.00	0.00	1.56	1.56
8.00	2.50	0.77	5.00	0.00	1.49	1.49
9.00	2.50	0.77	5.00	0.00	1.42	1.42
10.00	2.50	0.77	5.00	0.00	1.36	1.36
11.00	2.50	0.77	5.00	0.00	1.29	1.29
12.00	2.50	0.76	5.00	0.00	1.23	1.23
13.00	2.50	0.76	5.00	0.00	1.17	1.17
14.00	2.50	0.76	5.00	0.00	1.09	1.09
15.00	2.00	0.76	5.00	0.00	1.01	1.01
16.00	2.00	0.76	5.00	0.00	1.01	1.01
17.00	2.00	0.75	5.00	0.00	1.01	1.01
18.00	2.00	0.75	5.00	0.00	1.01	1.01
19.00	2.00	0.75	5.00	0.00	1.01	1.01
20.00	2.00	0.75	5.00	0.00	1.01	1.01
21.00	0.32	0.75	5.00	0.00	0.82	0.82
22.00	0.43	0.75	5.00	0.00	0.67	0.67
23.00	2.50	0.74	5.00	0.00	0.55	0.55
24.00	2.50	0.74	5.00	0.00	0.46	0.46
25.00	2.50	0.74	5.00	0.00	0.40	0.40
26.00	2.00	0.74	5.00	0.00	0.40	0.40

BA-1. sum						
27.00	2.00	0.74	5.00	0.00	0.40	0.40
28.00	2.00	0.73	5.00	0.00	0.40	0.40
29.00	2.00	0.73	5.00	0.00	0.40	0.40
30.00	2.00	0.73	5.00	0.00	0.40	0.40
31.00	2.51	0.72	5.00	0.00	0.36	0.36
32.00	2.50	0.72	5.00	0.00	0.32	0.32
33.00	2.49	0.71	5.00	0.00	0.26	0.26
34.00	2.47	0.71	5.00	0.00	0.20	0.20
35.00	2.46	0.70	5.00	0.00	0.13	0.13
36.00	2.00	0.69	5.00	0.00	0.13	0.13
37.00	2.00	0.69	5.00	0.00	0.13	0.13
38.00	2.00	0.68	5.00	0.00	0.13	0.13
39.00	2.00	0.67	5.00	0.00	0.13	0.13
40.00	2.00	0.67	5.00	0.00	0.13	0.13
41.00	2.00	0.66	5.00	0.00	0.13	0.13
42.00	2.00	0.65	5.00	0.00	0.13	0.13
43.00	2.00	0.65	5.00	0.00	0.13	0.13
44.00	2.00	0.64	5.00	0.00	0.13	0.13
45.00	2.00	0.63	5.00	0.00	0.13	0.13
46.00	2.32	0.63	5.00	0.00	0.11	0.11
47.00	2.31	0.62	5.00	0.00	0.08	0.08
48.00	2.30	0.62	5.00	0.00	0.05	0.05
49.00	2.29	0.61	5.00	0.00	0.03	0.03
50.00	2.28	0.60	5.00	0.00	0.00	0.00

---

\* F. S. <1, Liquefaction Potential Zone  
(F. S. is limited to 5, CRR is limited to 2, CSR is limited to 2)

Units: Unit: qc, fs, Stress or Pressure = atm (1.0581tsf); Unit Weight = pcf; Depth = ft; Settlement = in.

---

1 atm (atmosphere)	= 1 tsf (ton/ft <sup>2</sup> )
CRRm	Cyclic resistance ratio from soils
CSRsf	Cyclic stress ratio induced by a given earthquake (with user request factor of safety)
F. S.	Factor of Safety against Liquefaction, F. S. =CRRm/CSRsf
S_sat	Settlement from saturated sands
S_dry	Settlement from Unsaturated Sands
S_all	Total Settlement from Saturated and Unsaturated Sands
NoLi q	No-Liquefy Soils

# LIQUEFACTION ANALYSIS

## Eaton Wash

Hole No.=BE-1 Water Depth=28 ft

Magnitude=6.92  
Acceleration=0.909g

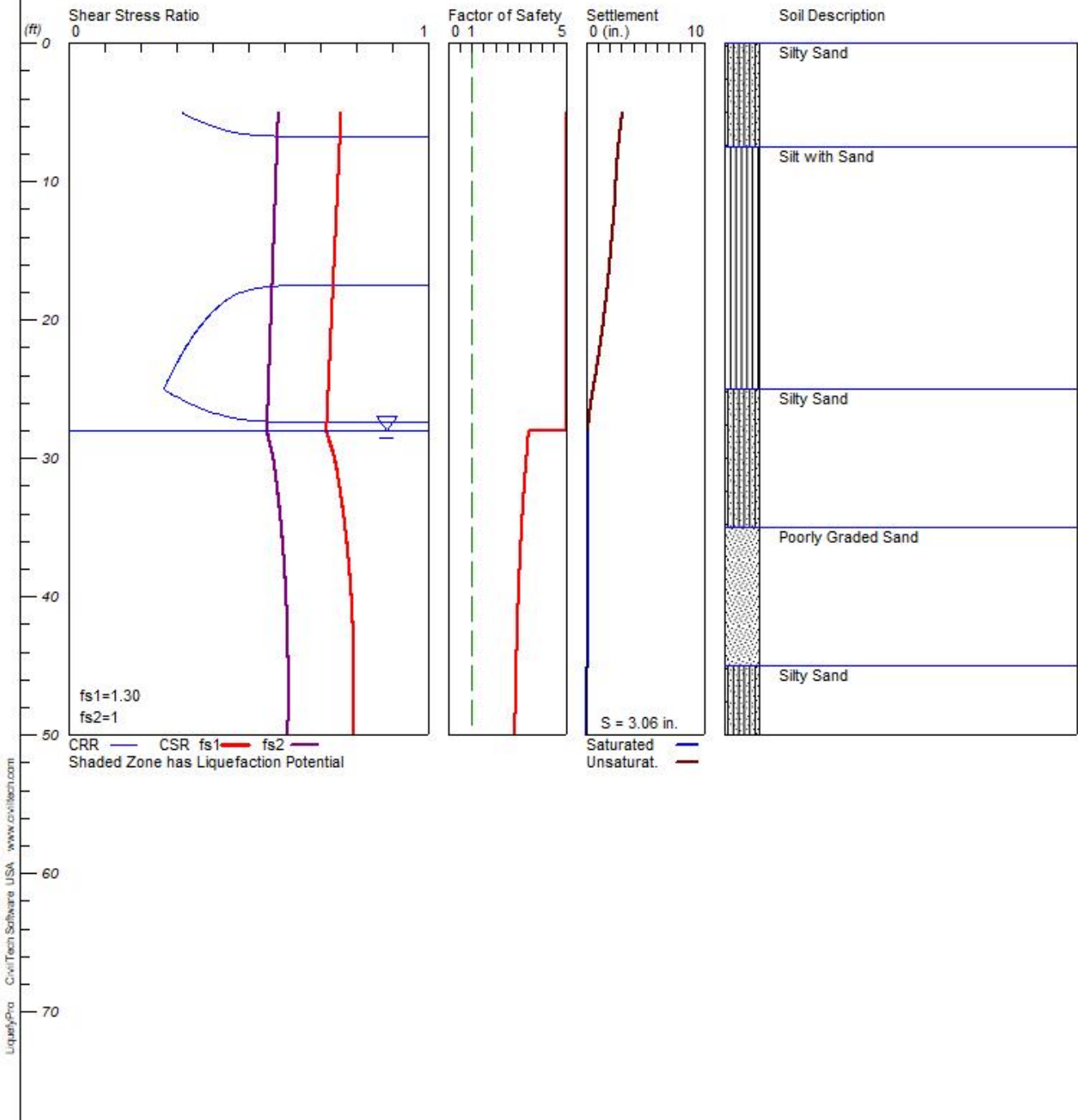

\*\*\*\*\*  
\*\*\*\*\*

LIQUEFACTION ANALYSIS SUMMARY

Copyright by CivilTech Software  
www.civilttechsoftware.com

\*\*\*\*\*  
\*\*\*\*\*

Font: Courier New, Regular, Size 8 is recommended for this report.  
Licensed to , 3/5/2019 2:41:42 PM

Input File Name: N:\Projects\2018\60185184\Working  
Files\Calculations-Analyses\BE-1.liq  
Title: Eaton Wash  
Subtitle: SGVCOG ACE Rio Hondo Load Reduction Strategy Design Project

Surface Elev. =  
Hole No. =BE-1  
Depth of Hole= 50.00 ft  
Water Table during Earthquake= 28.00 ft  
Water Table during In-Situ Testing= 50.00 ft  
Max. Acceleration= 0.91 g  
Earthquake Magnitude= 6.92

Input Data:

Surface Elev. =  
Hole No. =BE-1  
Depth of Hole=50.00 ft  
Water Table during Earthquake= 28.00 ft  
Water Table during In-Situ Testing= 50.00 ft  
Max. Acceleration=0.91 g  
Earthquake Magnitude=6.92  
No-Liquefiable Soils: CL, OL are Non-Liq. Soil

1. SPT or BPT Calculation.
  2. Settlement Analysis Method: Tokimatsu, M-correction
  3. Fines Correction for Liquefaction: Modify Stark/Olson
  4. Fine Correction for Settlement: During Liquefaction\*
  5. Settlement Calculation in: All zones\*
  6. Hammer Energy Ratio, Ce = 1.4
  7. Borehole Diameter, Cb= 1.15
  8. Sampling Method, Cs= 1.2
  9. User request factor of safety (apply to CSR) , User= 1.3  
Plot two CSR (fs1=User, fs2=1)
  10. Use Curve Smoothing: Yes\*
- \* Recommended Options



BE-1. sum

In-Situ Test Data:

Depth ft	SPT	gamma pcf	Fines %
5.00	7.00	100.00	30.00
7.50	7.00	120.00	72.00
10.00	10.00	120.00	72.00
15.00	9.00	120.00	71.00
20.00	6.00	120.00	71.00
25.00	6.00	100.00	48.00
30.00	22.00	100.00	40.00
35.00	29.00	100.00	5.00
40.00	33.00	100.00	5.00
45.00	21.00	100.00	32.00
50.00	26.00	100.00	32.00

Output Results:

Settlement of Saturated Sands=0.10 in.  
 Settlement of Unsaturated Sands=2.96 in.  
 Total Settlement of Saturated and Unsaturated Sands=3.06 in.  
 Differential Settlement=1.530 to 2.020 in.

Depth ft	CRRm	CSRfs	F. S.	S_sat. in.	S_dry in.	S_all in.
5.00	0.32	0.76	5.00	0.10	2.96	3.06
6.00	0.40	0.76	5.00	0.10	2.80	2.90
7.00	2.46	0.76	5.00	0.10	2.67	2.77
8.00	2.46	0.75	5.00	0.10	2.56	2.66
9.00	2.46	0.75	5.00	0.10	2.48	2.58
10.00	2.46	0.75	5.00	0.10	2.40	2.50
11.00	2.46	0.75	5.00	0.10	2.34	2.44
12.00	2.46	0.75	5.00	0.10	2.27	2.37
13.00	2.46	0.74	5.00	0.10	2.18	2.27
14.00	2.46	0.74	5.00	0.10	2.08	2.17
15.00	2.46	0.74	5.00	0.10	1.97	2.07
16.00	2.46	0.74	5.00	0.10	1.87	1.97
17.00	2.46	0.74	5.00	0.10	1.76	1.86
18.00	0.48	0.74	5.00	0.10	1.63	1.73
19.00	0.42	0.73	5.00	0.10	1.50	1.60
20.00	0.38	0.73	5.00	0.10	1.36	1.46
21.00	0.35	0.73	5.00	0.10	1.20	1.30
22.00	0.32	0.73	5.00	0.10	1.04	1.14
23.00	0.30	0.73	5.00	0.10	0.86	0.96
24.00	0.28	0.73	5.00	0.10	0.67	0.77
25.00	0.26	0.72	5.00	0.10	0.46	0.56
26.00	0.33	0.72	5.00	0.10	0.27	0.37

BE-1. sum						
27.00	0.44	0.72	5.00	0.10	0.12	0.22
28.00	2.46	0.72	5.00	0.10	0.01	0.10
29.00	2.46	0.73	3.37	0.09	0.00	0.09
30.00	2.46	0.74	3.32	0.09	0.00	0.09
31.00	2.45	0.75	3.28	0.09	0.00	0.09
32.00	2.44	0.75	3.23	0.09	0.00	0.09
33.00	2.43	0.76	3.19	0.09	0.00	0.09
34.00	2.42	0.77	3.16	0.09	0.00	0.09
35.00	2.41	0.77	3.12	0.09	0.00	0.09
36.00	2.39	0.77	3.09	0.09	0.00	0.09
37.00	2.38	0.78	3.06	0.09	0.00	0.09
38.00	2.37	0.78	3.03	0.09	0.00	0.09
39.00	2.36	0.78	3.01	0.09	0.00	0.09
40.00	2.35	0.79	2.98	0.09	0.00	0.09
41.00	2.34	0.79	2.96	0.09	0.00	0.09
42.00	2.33	0.79	2.94	0.09	0.00	0.09
43.00	2.32	0.79	2.92	0.09	0.00	0.09
44.00	2.31	0.79	2.91	0.08	0.00	0.08
45.00	2.30	0.79	2.89	0.06	0.00	0.06
46.00	2.29	0.80	2.88	0.04	0.00	0.04
47.00	2.28	0.80	2.86	0.02	0.00	0.02
48.00	2.27	0.79	2.85	0.00	0.00	0.00
49.00	2.26	0.79	2.84	0.00	0.00	0.00
50.00	2.25	0.79	2.83	0.00	0.00	0.00

---

\* F. S. <1, Liquefaction Potential Zone  
(F. S. is limited to 5, CRR is limited to 2, CSR is limited to 2)

Units: Unit: qc, fs, Stress or Pressure = atm (1.0581tsf); Unit Weight = pcf; Depth = ft; Settlement = in.

---

1 atm (atmosphere)	= 1 tsf (ton/ft <sup>2</sup> )
CRRm	Cyclic resistance ratio from soils
CSRsf	Cyclic stress ratio induced by a given earthquake (with user request factor of safety)
F. S.	Factor of Safety against Liquefaction, F. S. =CRRm/CSRsf
S_sat	Settlement from saturated sands
S_dry	Settlement from Unsaturated Sands
S_all	Total Settlement from Saturated and Unsaturated Sands
NoLi q	No-Liquefy Soils

# LIQUEFACTION ANALYSIS

## Rio Hondo BR-1

Hole No.=BR-1 Water Depth=25 ft

Magnitude=6.89  
Acceleration=0.925g

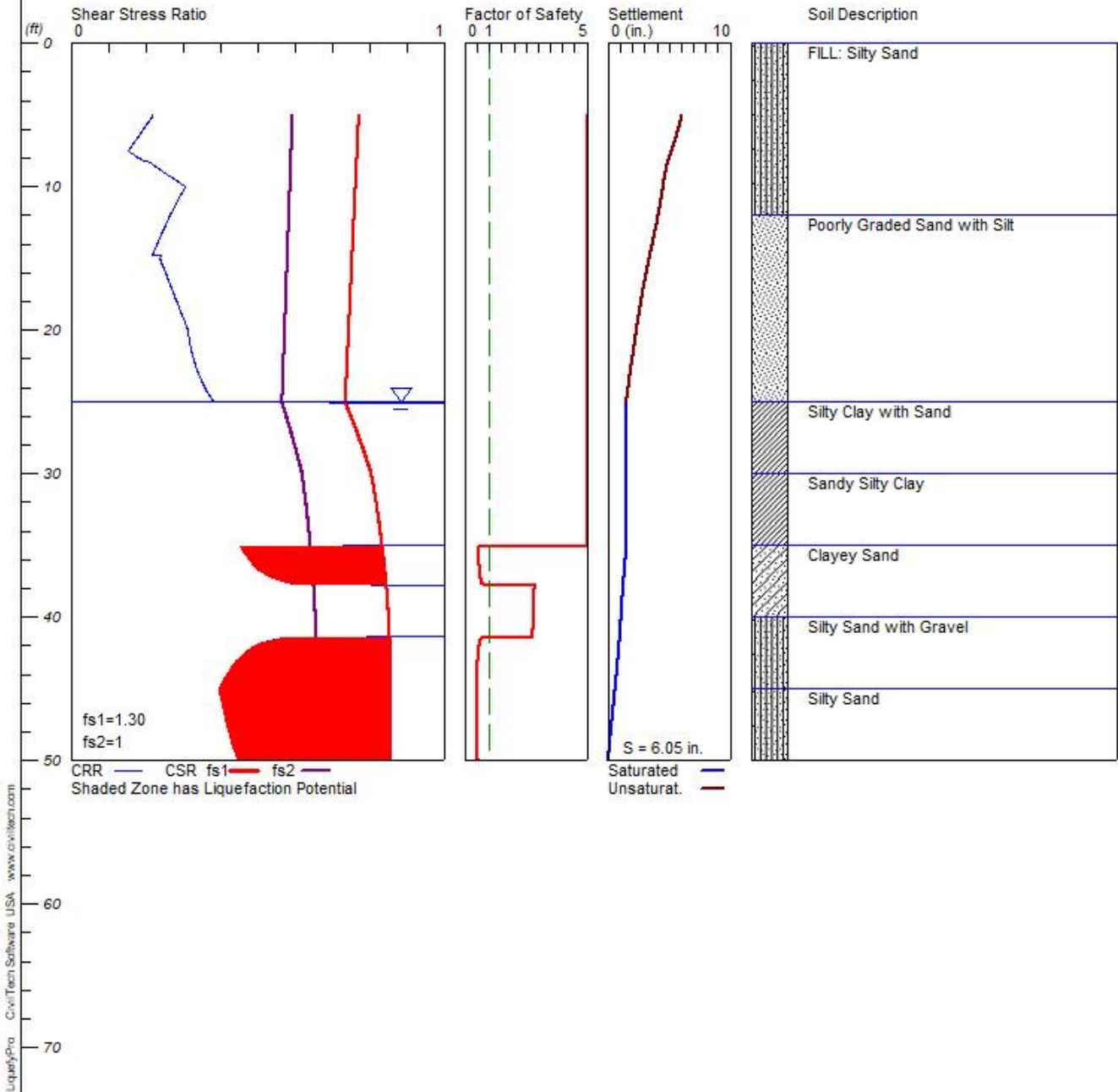

LiquifyPro CivilTech Software USA www.civiltect.com

\*\*\*\*\*  
\*\*\*\*\*

LIQUEFACTION ANALYSIS SUMMARY

Copyright by CivilTech Software  
www.civilttechsoftware.com

\*\*\*\*\*  
\*\*\*\*\*

Font: Courier New, Regular, Size 8 is recommended for this report.  
Licensed to , 3/5/2019 2: 42: 56 PM

Input File Name: N:\Projects\2018\60185184\Working  
Files\Calculations-Analyses\BR-1. liq  
Title: Rio Hondo BR-1  
Subtitle:

Surface Elev. =  
Hole No. =BR-1  
Depth of Hole= 50.00 ft  
Water Table during Earthquake= 25.00 ft  
Water Table during In-Situ Testing= 50.00 ft  
Max. Acceleration= 0.93 g  
Earthquake Magnitude= 6.89

Input Data:

Surface Elev. =  
Hole No. =BR-1  
Depth of Hole=50.00 ft  
Water Table during Earthquake= 25.00 ft  
Water Table during In-Situ Testing= 50.00 ft  
Max. Acceleration=0.93 g  
Earthquake Magnitude=6.89  
No-Liquefiable Soils: CL, OL are Non-Liq. Soil

1. SPT or BPT Calculation.
  2. Settlement Analysis Method: Tokimatsu, M-correction
  3. Fines Correction for Liquefaction: Modify Stark/Olson
  4. Fine Correction for Settlement: During Liquefaction\*
  5. Settlement Calculation in: All zones\*
  6. Hammer Energy Ratio, Ce = 1.4
  7. Borehole Diameter, Cb= 1.15
  8. Sampling Method, Cs= 1.2
  9. User request factor of safety (apply to CSR) , User= 1.3  
Plot two CSR (fs1=User, fs2=1)
  10. Use Curve Smoothing: Yes\*
- \* Recommended Options

BR-1. sum

In-Situ Test Data:

Depth ft	SPT	gamma pcf	Fines %
5.00	3.00	100.00	42.00
7.50	1.00	100.00	42.00
10.00	7.00	100.00	29.00
15.00	8.00	100.00	6.00
20.00	12.00	100.00	6.00
25.00	2.00	120.00	NoLi q
30.00	4.00	120.00	NoLi q
35.00	15.00	100.00	34.00
40.00	19.00	100.00	26.00
45.00	15.00	100.00	40.00
50.00	17.00	100.00	40.00

Output Results:

Settlement of Saturated Sands=1.49 in.  
 Settlement of Unsaturated Sands=4.55 in.  
 Total Settlement of Saturated and Unsaturated Sands=6.05 in.  
 Differential Settlement=3.023 to 3.990 in.

Depth ft	CRRm	CSRfs	F. S.	S_sat. in.	S_dry in.	S_all in.
5.00	0.22	0.77	5.00	1.49	4.55	6.05
6.00	0.19	0.77	5.00	1.49	4.25	5.75
7.00	0.17	0.77	5.00	1.49	3.89	5.39
8.00	0.18	0.77	5.00	1.49	3.49	4.98
9.00	0.25	0.77	5.00	1.49	3.20	4.70
10.00	0.31	0.76	5.00	1.49	3.00	4.49
11.00	0.28	0.76	5.00	1.49	2.81	4.30
12.00	0.26	0.76	5.00	1.49	2.60	4.10
13.00	0.25	0.76	5.00	1.49	2.38	3.87
14.00	0.23	0.76	5.00	1.49	2.13	3.62
15.00	0.24	0.75	5.00	1.49	1.86	3.36
16.00	0.25	0.75	5.00	1.49	1.62	3.12
17.00	0.27	0.75	5.00	1.49	1.40	2.90
18.00	0.28	0.75	5.00	1.49	1.20	2.69
19.00	0.30	0.75	5.00	1.49	1.00	2.50
20.00	0.31	0.75	5.00	1.49	0.82	2.31
21.00	0.32	0.74	5.00	1.49	0.64	2.14
22.00	0.33	0.74	5.00	1.49	0.47	1.96
23.00	0.34	0.74	5.00	1.49	0.30	1.80
24.00	0.36	0.74	5.00	1.49	0.14	1.64
25.00	0.38	0.74	5.00	1.49	0.00	1.49
26.00	2.00	0.75	5.00	1.49	0.00	1.49

							BR-1. sum
27.00	2.00	0.77	5.00	1.49	0.00	1.49	
28.00	2.00	0.78	5.00	1.49	0.00	1.49	
29.00	2.00	0.79	5.00	1.49	0.00	1.49	
30.00	2.00	0.81	5.00	1.49	0.00	1.49	
31.00	2.00	0.81	5.00	1.49	0.00	1.49	
32.00	2.00	0.82	5.00	1.49	0.00	1.49	
33.00	2.00	0.82	5.00	1.49	0.00	1.49	
34.00	2.00	0.83	5.00	1.49	0.00	1.49	
35.00	2.00	0.84	5.00	1.49	0.00	1.49	
36.00	0.48	0.84	0.57*	1.40	0.00	1.40	
37.00	0.52	0.84	0.62*	1.30	0.00	1.30	
38.00	2.41	0.85	2.85	1.21	0.00	1.21	
39.00	2.40	0.85	2.82	1.13	0.00	1.13	
40.00	2.39	0.85	2.80	1.05	0.00	1.05	
41.00	2.38	0.85	2.78	0.97	0.00	0.97	
42.00	0.49	0.86	0.57*	0.88	0.00	0.88	
43.00	0.44	0.86	0.52*	0.78	0.00	0.78	
44.00	0.42	0.86	0.49*	0.67	0.00	0.67	
45.00	0.40	0.86	0.46*	0.56	0.00	0.56	
46.00	0.40	0.86	0.47*	0.44	0.00	0.44	
47.00	0.41	0.86	0.48*	0.32	0.00	0.32	
48.00	0.42	0.86	0.49*	0.21	0.00	0.21	
49.00	0.43	0.86	0.51*	0.10	0.00	0.10	
50.00	0.45	0.86	0.52*	0.00	0.00	0.00	

---

\* F. S. <1, Liquefaction Potential Zone  
(F. S. is limited to 5, CRR is limited to 2, CSR is limited to 2)

Units: Unit: qc, fs, Stress or Pressure = atm (1.0581tsf); Unit Weight = pcf; Depth = ft; Settlement = in.

---

1 atm (atmosphere) = 1 tsf (ton/ft2)
CRRm                      Cyclic resistance ratio from soils
CSRsf                     Cyclic stress ratio induced by a given earthquake (with user request factor of safety)
F. S.                      Factor of Safety against Liquefaction, F. S. =CRRm/CSRsf
S_sat                     Settlement from saturated sands
S_dry                     Settlement from Unsaturated Sands
S_all                     Total Settlement from Saturated and Unsaturated Sands
NoLi q                    No-Liquefy Soils



---

**ATTACHMENTS FOR SECTION 8.7:**

**OTHER**

---

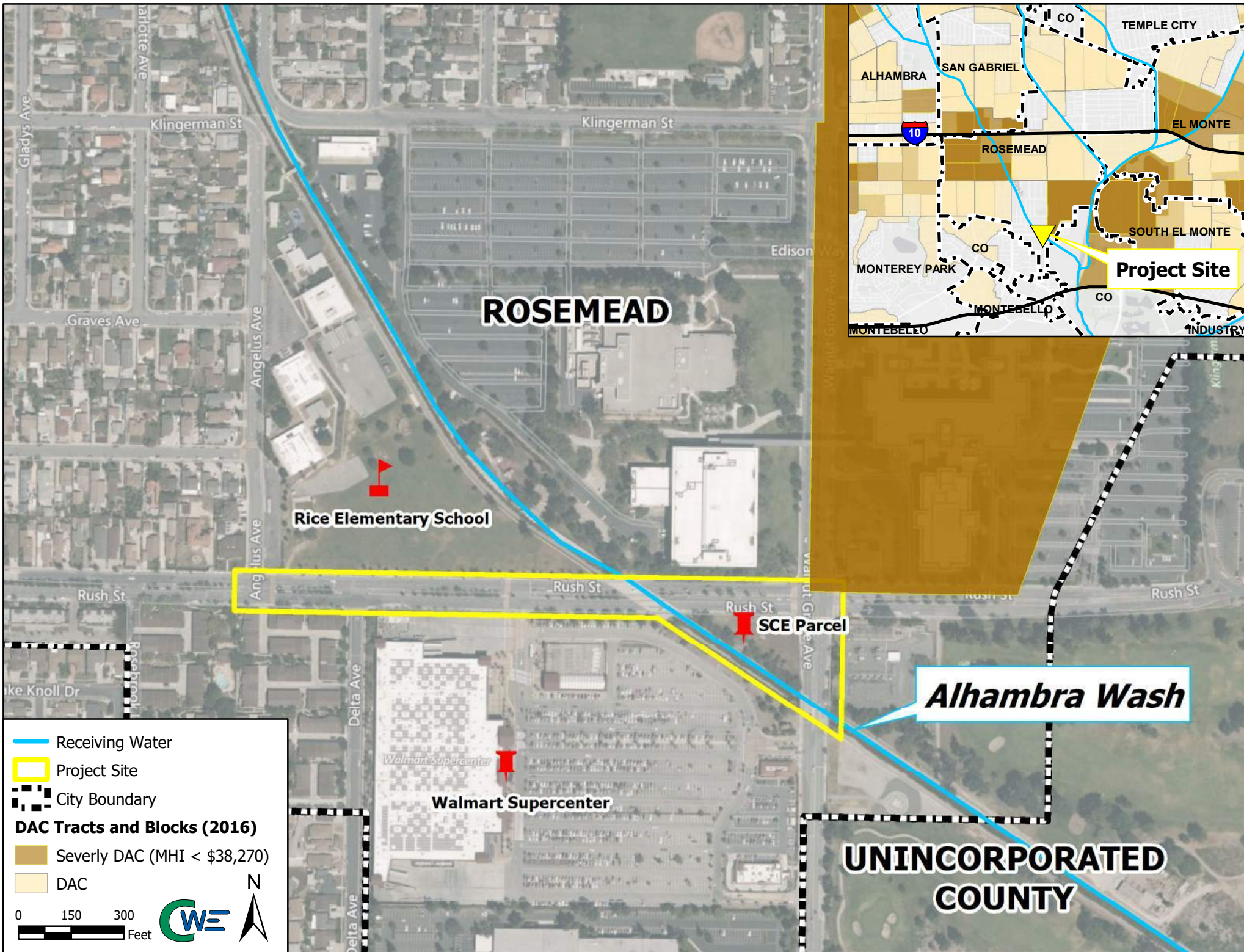

- Receiving Water
- Project Site
- City Boundary

**DAC Tracts and Blocks (2016)**

- Severly DAC (MHI < \$38,270)
- DAC

0 150 300 Feet

**CWE**

N





## SAFE, CLEAN WATER PROGRAM

---

# TECHNICAL RESOURCES SUMMARY

---

### *Regional Program Projects Module*

PROJECT CONCEPT NAME	Camino Verde Pocket Park Regional Stormwater Capture Demonstration Project
PROJECT CONCEPT LEAD(S)	City of South Pasadena
SCW WATERSHED AREA	Upper Los Angeles River
TOTAL SCW FUNDING REQUESTED FLAT RATE	\$ 300k

**Submitted On: Friday, July 30, 2021**

**Created By: H. Ted Gerber, Deputy Public Works Director, City of South Pasadena (H. Ted Gerber)**

## OVERVIEW

The Technical Resources Program is a part of the Safe, Clean Water Regional Program providing resources to community groups, municipalities, and individuals who need technical assistance to develop their Project concepts. Each Watershed Area Steering Committee will determine how to appropriate funds for the Technical Resources Program.

The Technical Resources Program funds the development of Project Feasibility Studies. Technical Assistance Teams will work with the necessary parties to add Projects for which there are completed Feasibility Studies to an eligible water quality plan, assist in acquiring a letter of support for non-Municipal Infrastructure Program Project Applicants, and address other prerequisites to apply to the Infrastructure Program. Upon completion, Feasibility Studies shall be submitted to the Watershed Area Steering Committees for consideration.

The Watershed Area Steering Committees will decide which Project concepts will be forwarded to the Technical Assistance Teams for development. The District will provide Technical Assistance Teams comprised of subject matter experts in Stormwater and/or Urban Runoff infrastructure design, hydrology, soils, Nature-Based Solutions, green infrastructure, Stormwater and/or Urban Runoff quality, water supply, recreation, open space, community needs, and other areas. The Technical Assistance Teams will complete Feasibility Studies in partnership with and on behalf of Municipalities, CBOs, NGOs, and others who may not have the technical resources or capabilities to develop Feasibility Studies.

This document summarizes a Project concept that is being proposed for Feasibility Study funding under the Technical Resources Program. This document is based upon inputs to and outputs from the web-based tool called the 'SCW Regional Program Projects Module' (<https://portal.safecleanwaterla.org/projects-module/>).

## **ORGANIZATIONAL OVERVIEW:**

### **1 GENERAL INFORMATION**

- 1.1 Overview
- 1.2 Project Location
- 1.3 Summary
- 1.4 Additional Information

### **2 DESIGN ELEMENTS**

- 2.1 Configuration
- 2.2 Capture Area
- 2.3 Site Conditions & Constraints
- 2.4 Cost
- 2.5 Operations & Maintenance
- 2.6 Additional Information

### **3 WATER QUALITY & WATER SUPPLY**

- 4.1 Water Quality
- 4.2 Water Supply
- 4.3 Additional Information

### **4 COMMUNITY**

- 5.1 Community Investment
- 5.2 Community Engagement
- 5.3 Additional Information

### **5 NATURE-BASED SOLUTIONS**

### **6 ATTACHMENTS**

# 1 GENERAL INFORMATION

This section provides general information on the Project concept including location and a brief description.

## 1.1 Overview

The following table provides an overview of the Project concept and the proposed Lead(s):

Project concept Name:	Camino Verde Pocket Park Regional Stormwater Capture Demonstration Project
Brief Project concept description:	We are requesting a feasibility study for the diversion, capture, and infiltration of regional stormwater flows at Camino Verde Pocket Park.
Call for Projects year:	FY22-23
SCW Watershed Area:	Upper Los Angeles River
Total Funding SCW Requested Flat Rate:	\$ 300k
Target Date of Completion:	7/31/2022
Project Concept Lead(s):	City of South Pasadena
Additional Project concept Collaborators:	N/A
Additional Project concept Collaborators:	N/A
Additional Project concept Collaborators:	N/A
LACFCD assistance for maintenance of the Project concept?	No
Is this a non-municipal project?	No
Primary Contact (if differs from submitter):	N/A
Primary Contact Email (if differs from submitter):	tgerber@southpasadenaca.gov
Secondary Contact (if differs from submitter):	N/A
Secondary Contact Email (if differs from submitter):	N/A

## 1.2 Project Location

The following table details the Project location:

Latitude:	34.099104
Longitude:	-118.169461
Street Address:	Camino Verde & Via Del Rey
City:	South Pasadena
State:	CA
Zip Code:	91030
Municipality:	South Pasadena

**Is the project located within or providing a benefit to a Disadvantaged Community (DAC)?**

Yes

**The following is a summary of how the Project concept will benefit its DAC with a discussion of measures on displacement avoidance:**

According to the California Department of Water Resources' DAC Mapping Tool (2018 Census Data), there is a DAC block group to the immediate south of the project area. (GEOID 060372011103.) The block group is illustrated on the map attached to this application, and also at <https://gis.water.ca.gov/app/dacs>. DAC benefits include potential improvements to the pocket park as described in the Design Elements section of this application.

**Please see attached letter of non-objection from the municipality in which the project concept is being proposed:**

Attachments for this Section	
Attachment Name	Description
Location map	Location map

## 1.3 Summary

Attachments for this Section	
Attachment Name	Description
SP1 Camino Verde Pocket Park Regional Stormwater Capture Demonstration Project Illustrative Summary.pdf	Camino Verde Pocket Park Regional Stormwater Capture Demonstration Project Illustrative Summary

**Please describe the historical background of the Project concept, including but not limited to: a**

**background of the level of community engagement conducted so far; a summary of who has been involved in the concept to date, and a summary of the work done by these project partners and collaborators (consultants, municipalities, NGOs, CBOs, etc); as well as other important historical project background that may be important for your WASC to know about the project. Please also state which regional water management plan includes the proposed project (SWRP, E/WMP, IRWMP or other, if applicable):**

The main driver for this project is to meet the City's water quality/stormwater capture targets identified in the Upper LA River EWMP. Table 7A-39 of Appendix 7 of the EWMP identifies twelve subwatersheds that require specific volumes of stormwater capture by 2028 and 2037. Three of these subwatersheds are part of the Rio Hondo watershed. The City has marginal drainage to Rio Hondo and so has little available space for an infrastructure project. The City's plan for this area is to support a project led by a neighboring, downstream jurisdiction. Six subwatersheds drain to the Arroyo Seco. These subwatersheds are being addressed by a separate project that received SCW TRP funding in 2020-21. The three remaining subwatersheds drain directly to the LA River. One of these subwatersheds is being addressed by a separate project that received SCW TRP funding in 2021-22. This project addresses one of the remaining two subwatersheds (ID 636280). Additional water quality information is included in the Water Quality section of this application.

A secondary driver for this project is the City's interest in improving its parks. The City has set several policies and goals in its General Plan and Downtown Specific Plan Update & 2021–2029 Housing Element to develop distributed parks throughout the city, ensuring close proximity and easy access from residences. City parks are an essential resource in preserving the sustainability and long-term health of the City's tree canopy. As such, the City is actively pursuing these pocket park improvements in its Parks & Recreation Commission (PRC), having acquired several small properties over the last five years. The City's Natural Resources & Environmental Commission (NREC) is charged with implementing the goals of the City's Green Action Plan and Climate Action Plan, which include expanding the City's tree canopy to increase local carbon sequestration and mitigate detrimental heat island effects. The PRC and NREC hold monthly public meetings engaging the community on potential projects and programs, including this and other pocket parks, to meet these goals. In addition to regional stormwater capture, community benefits under consideration for the City's pocket parks include incorporating benches, café/picnic tables, fitness stations, small play courts, public art pieces, or a highly concentrated Miyawaki urban forest. Camino Verde Pocket Park was identified as a candidate for stormwater capture due to the identification of a 72-inch storm drain pipe and a 15-inch sanitary sewer pipe directly beneath the park. Should this project proceed, some of these additional community benefits will also be incorporated. (The current location currently has mature trees, so any addition of trees would be within the remaining open space.)

The current concept places most of the project footprint within Van Horn Avenue at the southern end of the pocket park. This specific area is listed in the EMWP as a project location for stormwater capture or treatment in Appendix 6, Table 6.E-18, page 6.E.323.

# 1.4 Additional Information

Additional general information regarding Project concept is provided as the following attachments:

Attachments for this Section	
Attachment Name	Description
Pocket Park DAC 2018 map	Pocket Park DAC 2018 map

## 2 DESIGN ELEMENTS

This section provides an overview of the anticipated design elements for the Project concept.

### 2.1 Configuration

**The following is a description of the Project concept layout including its anticipated footprint and key components:**

The project concept is to divert wet and dry weather flow from an underground 72 inch storm drain pipe to an underground retention system. The storm drain pipe drains a residential area of about 280 acres, and runs beneath a City-owned pocket park known as Camino Verde Pocket Park. The diversion point and retention system will be located at the southern end of the pocket park (34.09873, -118.16947). The current concept for capturing wet and dry weather flows is through a proprietary system called WaterSilo. WaterSilo are vertical cisterns that store stormwater and are also equipped with infiltration dry wells. This design is useful for this project as it addresses the need to capture regional flows within a small footprint. The concept includes a cluster of up to seven 30,000 gallon WaterSilo cisterns. (Seven cisterns would capture the 85th percentile, 24 hour storm event.) Alternative designs will be considered through the requested feasibility study.

The project was selected in part due to the following promising features:

- The storm drain diversion point passes through the footprint of the project. This feature removes the cost and construction impact of installing a long underground diversion pipe.
- A 15 inch sanitary sewer line also passes through the footprint of the project. Should infiltration be deemed infeasible, this allows for an alternative approach to water supply where detained stormwater could be released to the sanitary sewer system.
- The City is interested in improving pocket parks. Improvements under consideration include benches, café/picnic tables, fitness stations, small play court, a public art piece, or a highly concentrated Miyawaki urban forest. (The location of this pocket park currently has mature trees, so any addition of trees would be within the remaining open space.)
- The opportunity to educate the public. The Camino Verde Pocket Park serves as a pedestrian connection between the Cities of South Pasadena and Los Angeles. South Pasadena residents use this route in part to access the Elephant Hill Open Space, which is about 1,000 feet to the southwest. This presents the Pocket Park as an ideal location to include an interpretive sign to educate residents on the purpose and function of this project.

The project was also selected to demonstrate the feasibility of capturing regional wet weather flows in an area of limited space (i.e., a pocket park). The potential benefits to a successful demonstration include:

- Minimizing the impact of construction: The construction timeframe for this project is four months, and a WaterSilo cistern can be installed in one day. Also, the construction footprint is not used for recreation or as a vehicle crossing. (The footprint is currently used for street parking and as a pedestrian right of way connecting Van Horne Avenue in the City of LA to Camino Verde in South Pasadena via Camino Verde Pocket Park.)
- Minimizing cost: The preliminary cost estimate for the construction element of this regional project is \$1.5 million.
- Increasing project location opportunities: If the project is successful, it demonstrates that city-owned property that may be overlooked due to size constraints can in fact be used for regional stormwater capture. This would help reduce the need to acquire private property to install these systems, and so



decrease cities' overall cost to meet surface water quality targets.

Illustrations of the concept layout are included as an attachment.

**Specify whether the project is Wet or Dry:**

Wet

**Estimated Capacity for the Project concept:**

4.8 ac-ft

## 2.2 Capture Area

The size and land uses of the capture area upstream of a project plays an important role in its water quality and water supply benefits.

**The following table details the capture area and its imperviousness:**

Capture Area Summary	
Capture Area:	283.6 ac
Impervious Area:	60.78 ac
Pervious Area:	222.82000000000002 ac

**The following table is a summary of the land use breakdown for the impervious area that drains to the project:**

Breakdown of Impervious Acreage in Capture Area		
Land Use Type	Percent Impervious	Acres
Institutional	7.6 %	4.62
Secondary Roads and Alleys	26.2 %	15.92
Single Family Residential	65.7 %	39.93
Vacant	0.5 %	0.3

## 2.3 Site Conditions & Constraints

**The following is a summary of engineering analyses performed to date, and a description of existing and / or potential constraints or limitations due to existing conditions.**

This project concept is planning-level and subject to review and revision during project design. A variety of confounding factors, including geotechnical and environmental considerations, will need to be further investigated to inform project design. Factors to be considered include but are not limited to the following:

- Drainage delineation: the drainage was delineated using best available data in GIS analysis. A site visit and grading analysis should be performed before design to refine the capture areas and ensure maximum capture of runoff.
- Groundwater levels: the distance between the bottom of the infiltrating surface and the seasonal high groundwater level should be at least 5 feet apart to allow for adequate infiltration. This should be confirmed prior to construction.

- Infiltration rates: Infiltration rates can vary from site to site. Infiltration tests should be performed prior to construction to ensure the structure is sized appropriately.
- Tree removal: It is not anticipated that tree removal will be necessary. However, tree removal could disturb active nests or destroy protected trees, which may increase time for site-specific CEQA compliance.
- Utilities: a utilities survey should be performed during design to ensure no utilities will be disrupted during construction.
- Jurisdictional access closure: The temporary closing of access of the pedestrian path through the pocket park from South Pasadena to Los Angeles (and vice-versa) during the construction phase of the project.
- Environmental factors: additional investigation should be performed at project sites to assess the possibility of interference of existing contamination with stormwater infiltration.

## 2.4 Cost

**The following tables provide details on the anticipated capital and annualized costs for the Project concept:**

Capital Cost Breakdown	
Construction Cost:	\$ 1,500,000.00
Planning and Design Cost*	\$ 450,000.00

\*Includes early concept design, pre-project monitoring, feasibility study development, site investigations, formal project design, intermediate and project completion audits, CEQA and other environmental impact studies and permitting.

Annual Cost Breakdown	
Annual Maintenance Cost:	\$ 14,000.00
Annual Operation Cost:	\$ 5,000.00
Annual Monitoring Cost:	\$ 5,000.00
Project Life Span:	50 years

## 2.5 Operations & Maintenance

**The following is a description of the operations and maintenance needs for the Project:**

Maintenance activities include annual inspection and maintenance to verify proper operation of the facility. This includes cleaning to remove accumulated trash, grit, sediments, and other debris. Pumps also require replacement after 15 years. Operation activities include pump power consumption for drawdown.

Detailed operations and maintenance needs will be determined through the feasibility study process.

**The following is the agency and contact person that will be responsible for operations and maintenance of the Project:**

City of South Pasadena, Ted Gerber, Deputy Public Works Director

**The following expertise or technical training is necessary to perform basic operation and maintenance of the Project:**

The expertise or technical training necessary to perform basic operation and maintenance of the Project may include vector truck operators and mechanical laborers. Specific technical training required will be determined through the feasibility study process.

## 2.6 Additional Information

**Additional information regarding design elements for the Project concept is provided as the following attachments:**

Attachments for this Section	
Attachment Name	Description
Project preliminary concept design	Project preliminary concept design
Drainage system maps for project and upstream area	Drainage system maps for project and upstream area

### 3 WATER QUALITY & WATER SUPPLY

This section provides an overview of project elements that will provide water quality and water supply benefits.

#### 3.1 Water Quality

**The following describes how the Project concept will address primary pollutants of concern:**

This project will capture stormwater and urban runoff from a large drainage area, prior to discharge to surface waters. This will in turn capture pollutants in the stormwater and urban runoff and prevent the pollutants' release to the LA River (and upstream Laguna Channel). The primary pollutants that will be captured and prevented from being released to these downstream waterbodies include bacteria, metals, toxics, and trash. For more information on these primary pollutants, see the following application response.

**The following describes the water quality concerns in the vicinity and downstream of the proposed Project concept area:**

The LA River is impaired and is under TMDLs for dry and wet weather bacteria, metals including zinc and copper, and trash. The harbor at the LA River estuary is impaired for toxic chemicals. This project will support the Upper LA River EWMP Group's effort to attain its dry weather bacteria targets, as well as its 2028 and 2037 final TMDL/EWMP stormwater compliance targets for the LA River. Specifically, the project will help achieve the EWMP's predicted stormwater capture capacity for the subwatershed that it is within: Subwatershed ID# 636280 requires 3.4 acre-feet of stormwater capture capacity by 2028 and 5.1 acre-feet by 2037. (See EWMP Appendix 7, Table 7A-40.)

#### 3.2 Water Supply

**The following describes and justifies the nexus between water supply and the stormwater and/or urban runoff that will be captured/infiltrated/diverted by the Project:**

If feasible, stormwater captured will be infiltrated and used to recharge groundwater supplies. If infiltration is not feasible, captured runoff could be detained, then released to an existing 15-inch sanitary sewer trunk line that, similar to the storm drain pipe, passes the intersection of Camino Verde and Via Del Rey. Captured water could also be used to supplement irrigation of the pocket park. This would be determined through the feasibility study requested through this application.

**Will this Project capture water for onsite irrigation use?**

Yes

**The following describes onsite use by the Project:**

Captured water could be used to supplement irrigation of the pocket park. This would be determined through the feasibility study requested through this application.

**Will this Project capture water used for water recycling by a wastewater treatment facility?**

No

**The following describes water recycling by the project:**

If infiltration is not feasible, captured flows would be detained, then released to an existing sanitary sewer trunk line located below Camino Verde.

**Will the Project be connected to a managed water supply aquifer?**

Yes

**If Yes, managed Aquifer Name:**

Main San Gabriel Basin

**3.3 Additional Information**

**Additional information regarding water quality and water supply benefits of the Project concept is provided as the following attachments:**

Attachments for this Section	
Attachment Name	Description
Project location within LA River	Project location within LA River

## 4 COMMUNITY

This section provides an overview of project elements related to community investment benefits and community engagement performed to date.

### 4.1 Community Investment

The following table details the Project’s anticipated community investment benefits:

Community Investment		
Investment Type	Applicable?	Detailed Description
Does this project improve flood management, flood conveyance, or flood risk mitigation?	Yes	The project will increase flood protection through reduced peak flow rates from peak flow attenuation in the existing storm drain system.
Does this project create, enhance, or restore park space, habitat, or wetland space?	Yes	Park enhancements under consideration include benches, café/picnic tables, fitness stations, small play court, or a public art piece.
Does this project improve public access to waterways?	No	N/A
Does this project create or enhance new recreational opportunities?	Yes	Park enhancements under consideration include benches, café/picnic tables, fitness stations, small play court, or a public art piece.
Does this project create or enhance green spaces at school?	No	N/A
Does this project reduce heat local island effect and increase shade?	Yes	A park enhancement under consideration is a small, concentrated urban forest.
Does this project increase shade or the number of trees or other vegetation at the site location?	Yes	A park enhancement under consideration is a small, concentrated urban forest.

### 4.2 Community Engagement

The following describes the effort of outreach and engagement that has occurred to date and identify (if any) agencies / municipalities / stakeholders that were involved in the development of the Project concept:

The City is actively pursuing pocket park improvements in its Parks & Recreation Commission (PRC), having acquired several small properties over the last five years. The City’s Natural Resources & Environmental Commission (NREC) is charged with implementing the goals of the City’s Green Action Plan and Climate Action Plan, which include expanding the City’s tree canopy to increase local carbon sequestration and mitigate detrimental heat island effects. The PRC and NREC hold monthly public meetings engaging the community on potential projects and programs, including this and other pocket parks, to meet these goals.

The following describes the plan to outreach and engage the community during the early development phase of the Project:

Through the feasibility study process, the City will hold community-based workshops with the general public and other stakeholders, such as local environmental groups. The workshops will inform stakeholders on the City's project approach, and allow them to participate in project development.

### **4.3 Additional Information**

**Additional information regarding community benefits and engagement for the Project concept is provided as the following attachments:**

## 5 NATURE-BASED SOLUTIONS

This section provides an overview of Project elements that will leverage nature-based solutions.

### **Will this Project implement natural processes?**

Yes

### **The following is a description of natural processes that will be implemented:**

The underground stormwater capture system will mimic natural processes to slow, detain, capture, and (potentially) infiltrate water, which will help protect and enhance downstream surface waters.

### **Will this project utilize natural materials?**

No

### **The following is a description of natural materials that will be utilized:**

N/A

**The following describes how nature-based solutions are utilized to the maximum extent feasible. If nature-based solutions are not used, a description of what options have been considered and why they were not included is provided.**

N/A



## 6 ATTACHMENTS

Attachments are bundled and organized in the following pages, with cover pages between each subsection.



---

## **ATTACHMENTS FOR SECTION 1.3:**

### **Illustrative Overview**

---

# Camino Verde Pocket Park Regional Stormwater Capture Demonstration Project

Safe, Clean Water Technical Resources Program



## Project Overview

**Project Type:** Regional stormwater capture system

**Location:** Camino Verde Pocket Park in the City of South Pasadena. The project footprint is at the park's southern end (34.09873, -118.16947).



**Key Benefits:**

- Water quality (regional stormwater capture)
- Water supply (aquifer recharge or reclamation)
- Community (improvements to pocket park)

**Demonstration:** Demonstrating the feasibility of capturing regional stormwater flows at a small property

**TRP Request:** The preparation of a Feasibility Study following SCWP guidelines

## Water Quality & Supply

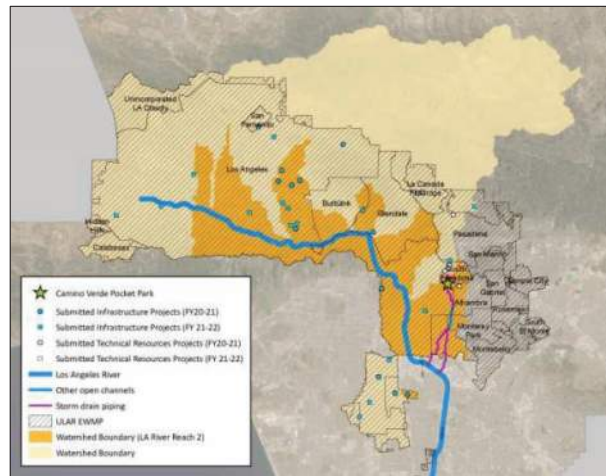

**Watershed and Receiving Waters**

The project is located within the eastern limits of the urbanized Upper LA River watershed management area. The project will capture wet and dry weather flows from a regional drainage area. This volume capture will in turn capture pollutants, thus preventing their discharge to the LA River (and upstream Laguna Channel). The primary pollutants captured include bacteria, metals, toxics, and trash. The LA River is impaired for bacteria, metals, and trash, and the harbor at the LA River estuary is impaired for toxic chemicals. As such this project will support the Upper LA River Watershed Management Group in its effort to attain its surface water quality targets.

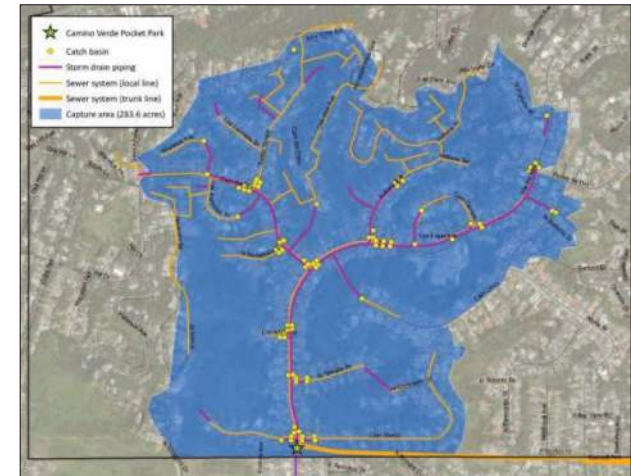

**Drainage Area and Drainage Systems Layout**

The project diverts and captures wet and dry weather flows from a 72 inch underground storm drain pipe that passes beneath the pocket park. The upstream drainage area of the storm drain pipe is about 280 acres. The estimated 85<sup>th</sup> percentile storm event volume is 4.8 acre-feet.

There is also a 15 inch sewer line that passes through part of the pocket park. This provides an opportunity to reclaim detained stormwater, should infiltration be deemed infeasible.

# Camino Verde Pocket Park Regional Stormwater Capture Demonstration Project

## Safe, Clean Water Technical Resources Program



### Water Quality & Supply (continued)

### Community Benefits



#### Project Area

The pocket park is located north of ≈0.07 acres of city-owned right-of-way. The public right-of-way is the end of a small residential road that is currently used for street parking and accessing easements. This space could be used to both divert runoff from the adjacent underground storm drain pipe and to install the stormwater capture system. For the purposes of this application, the maximum capture capacity within this space is estimated at 4.8 acre-feet.

Achieving the maximum storage capacity may involve adding a small portion of the southern end of the park to the construction footprint.

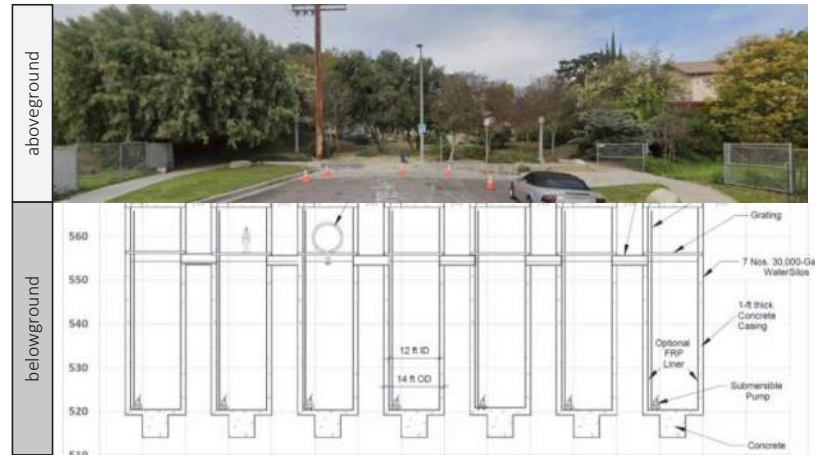

#### Stormwater Capture System

The current concept for capturing wet and dry weather flows is through a proprietary system called WaterSilo. WaterSilo are vertical cisterns that store stormwater and are also equipped with infiltration dry wells. This design is useful for this project as it addresses the need to capture regional flows within a small footprint. The concept includes a cluster of up to seven 30,000 gallon WaterSilo cisterns. (Seven cisterns would capture the 85th percentile, 24 hour storm event.) The cisterns would be installed within the Project Area described in this Illustrative Summary.

Alternative designs will be considered through the requested feasibility study.

- **Improved flood management.** The project will increase flood protection through reduced peak flow rates from peak flow attenuation in the existing storm drain system.
- **Pocket park improvements.** Improvements under consideration include benches, café/picnic tables, fitness stations, small play court, a public art piece, or a highly concentrated Miyawaki urban forest. (The current location currently has mature trees, so any addition of trees would be within the remaining open space.)
- **Public education.** The Camino Verde Pocket Park serves as a pedestrian connection between the Cities of South Pasadena and Los Angeles. South Pasadena residents use this route in part to access the Elephant Hill Open Space, which is about 1,000 feet to the southwest. This presents the Pocket Park as an ideal location to include an interpretive sign to educate residents on the purpose and function of this project.





---

## **ATTACHMENTS FOR SECTION 1.2:**

**Location**

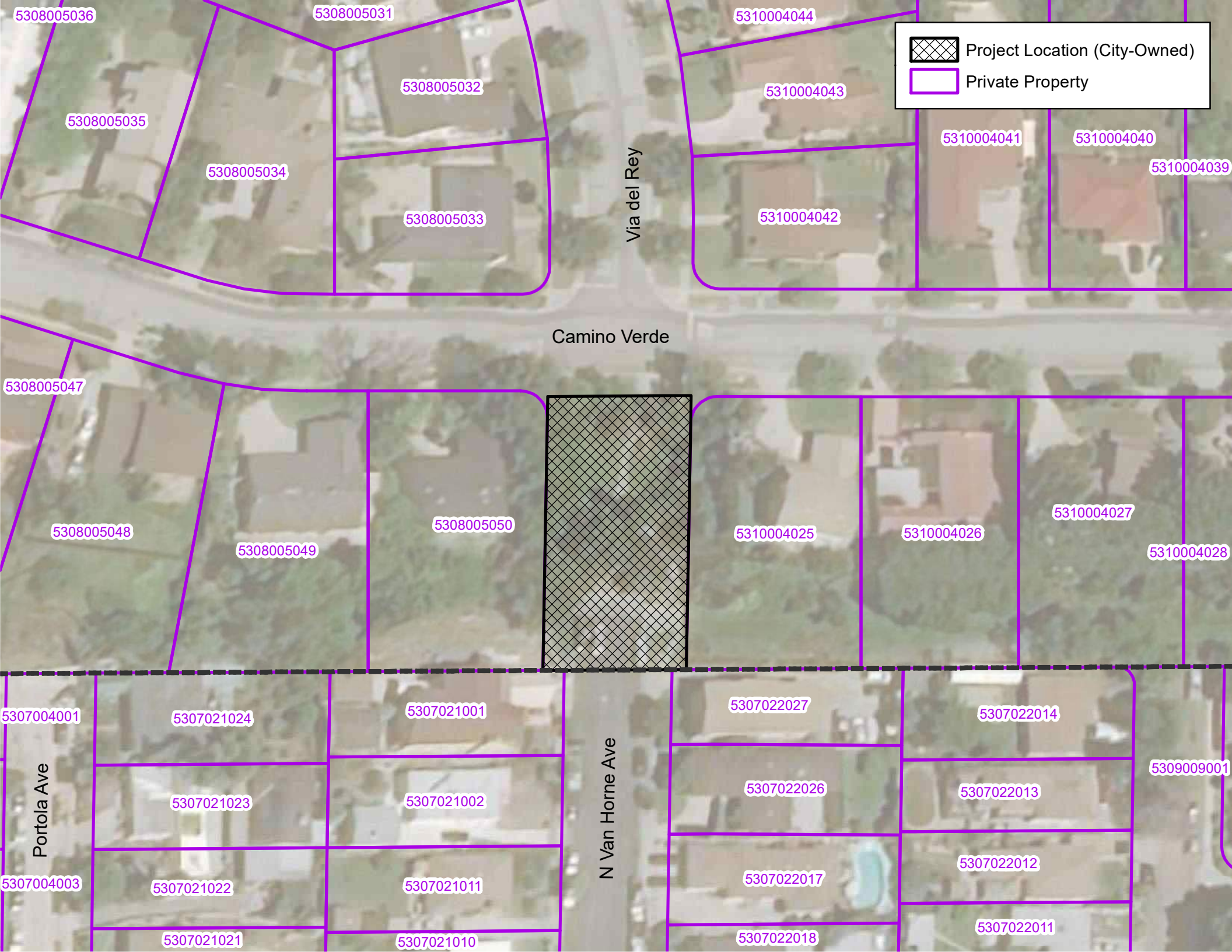
---



 Project Location (City-Owned)  
 Private Property

Via del Rey

Camino Verde

N Van Horne Ave

Portola Ave

5308005036

5308005031

5310004044

5308005035

5308005032

5310004043

5308005034

5308005033

5310004042

5310004041

5310004040

5310004039

5308005047

5308005048

5308005049

5308005050

5310004025

5310004026

5310004027

5310004028

5307004001

5307021024

5307021001

5307022027

5307022014

5309009001

5307021023

5307021002

5307022026

5307022013

5307004003

5307021022

5307021011

5307022017

5307022012

5307021021

5307021010

5307022018

5307022011



---

## **ATTACHMENTS FOR SECTION 1.4:**

### **General Information**

---



Camino Verde Pocket Park



Capture area (283.6 acres)



Disadvantaged Community Census Block Group

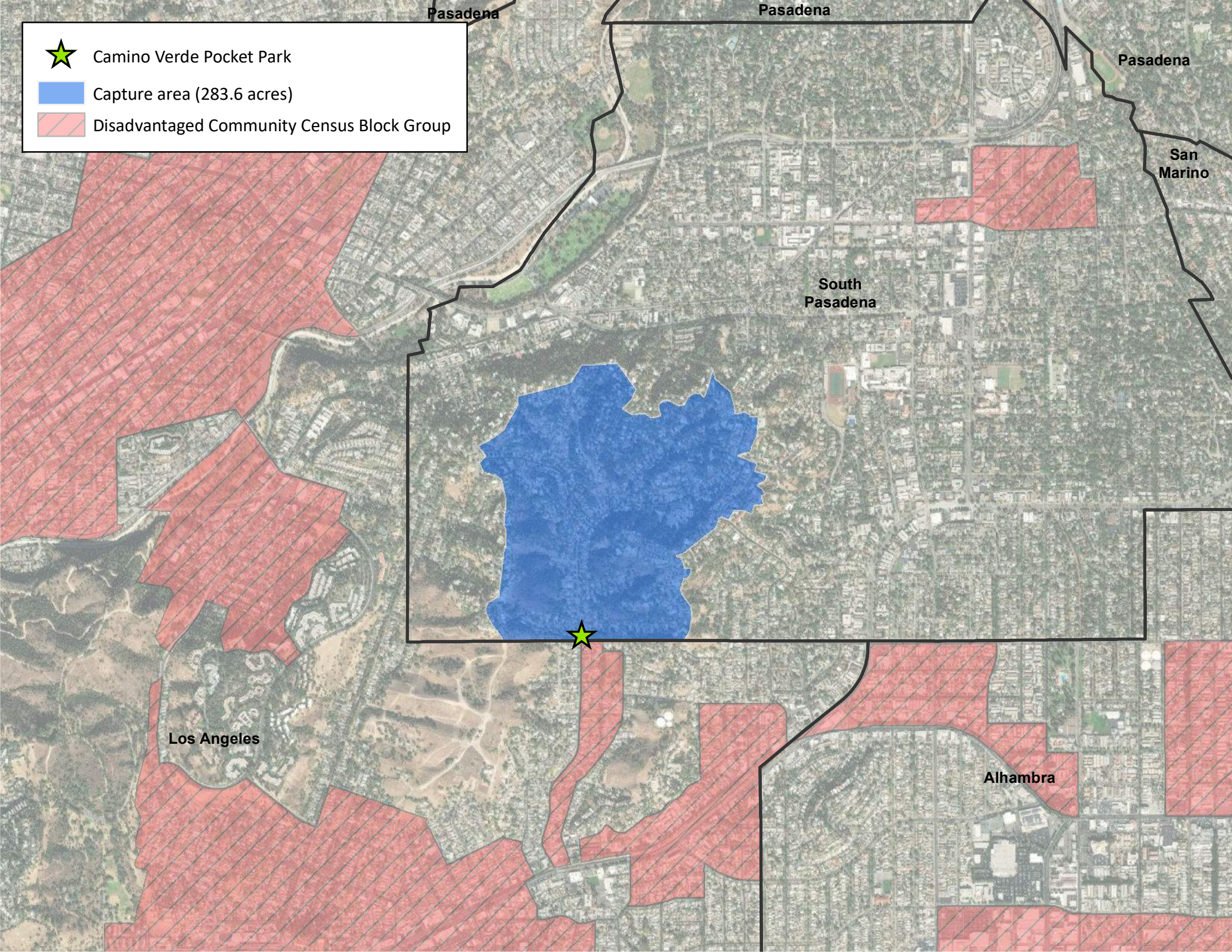





---

## **ATTACHMENTS FOR SECTION 2**

### **Design Elements**

---

NavigateLA Map

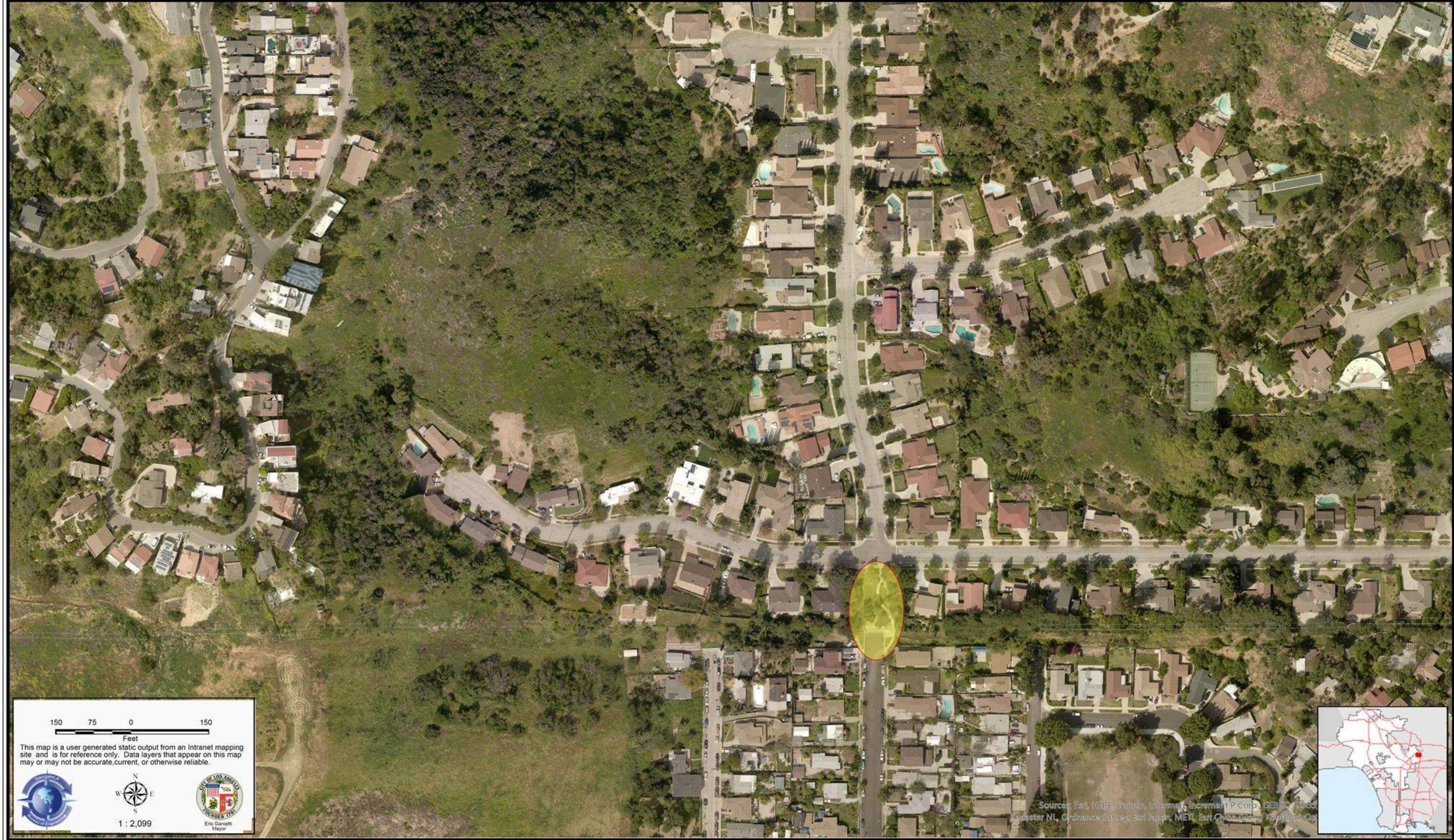

Project Site

July 26, 2021



Safe, Clean Water Program  
S. Pasadena Van Horne Ave Pocket Park  
Stormwater Capture Project



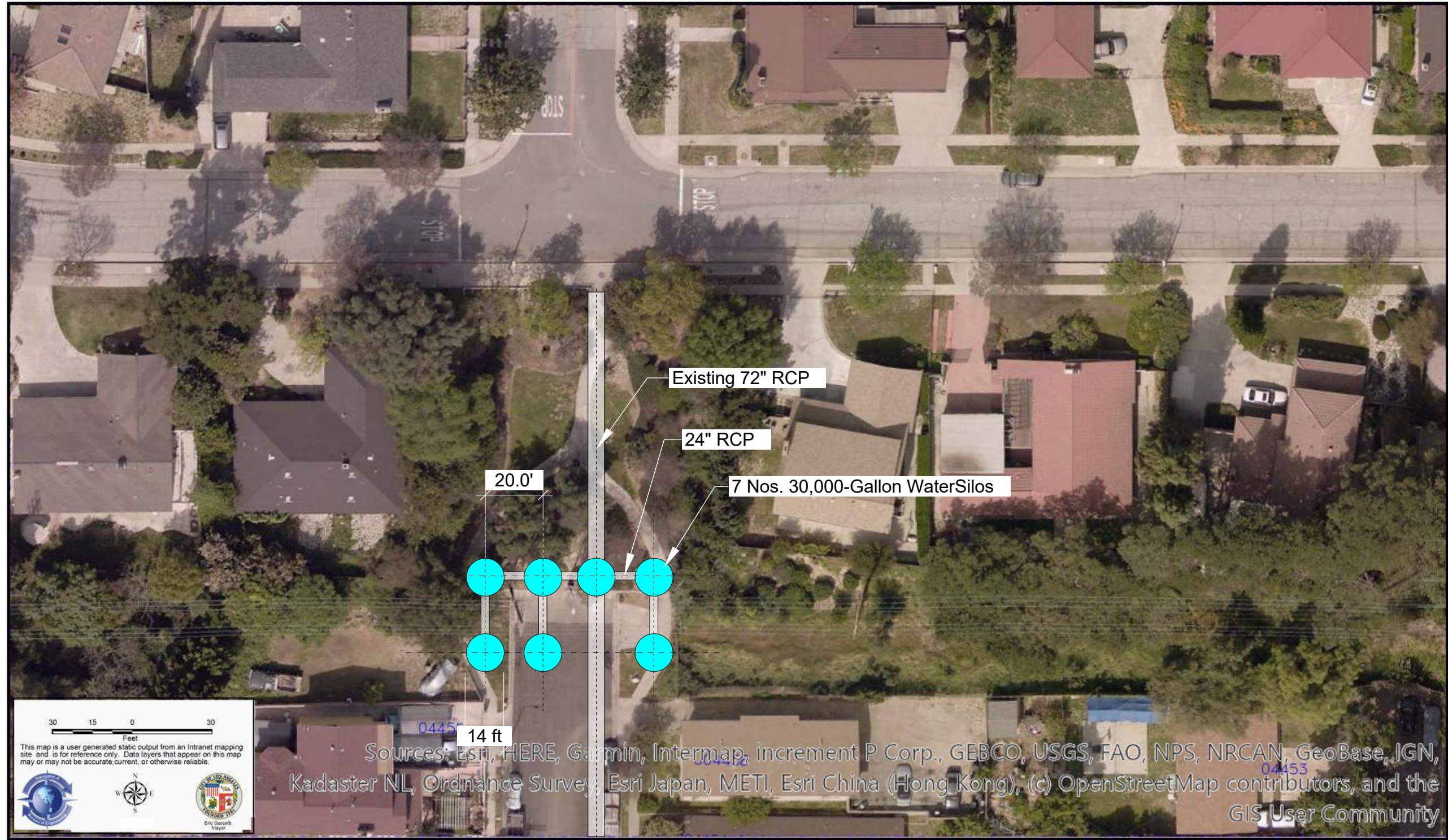

30 15 0 30  
Feet

This map is a user generated static output from an Intranet mapping site and is for reference only. Data layers that appear on this map may or may not be accurate, current, or otherwise reliable.

Sources: Esri, HERE, Garmin, Intermap, increment P Corp., GEBCO, USGS, FAO, NPS, NRCAN, GeoBase, IGN, Kadaster NL, Ordnance Survey, Esri Japan, METI, Esri China (Hong Kong), (c) OpenStreetMap contributors, and the GIS User Community

Plan



S. Pasadena Van Horne Ave Pocket Park  
Stormwater Capture Project

MM/DD/YY	REMARKS
1	...
2	...
3	...
4	...
5	...

02

A



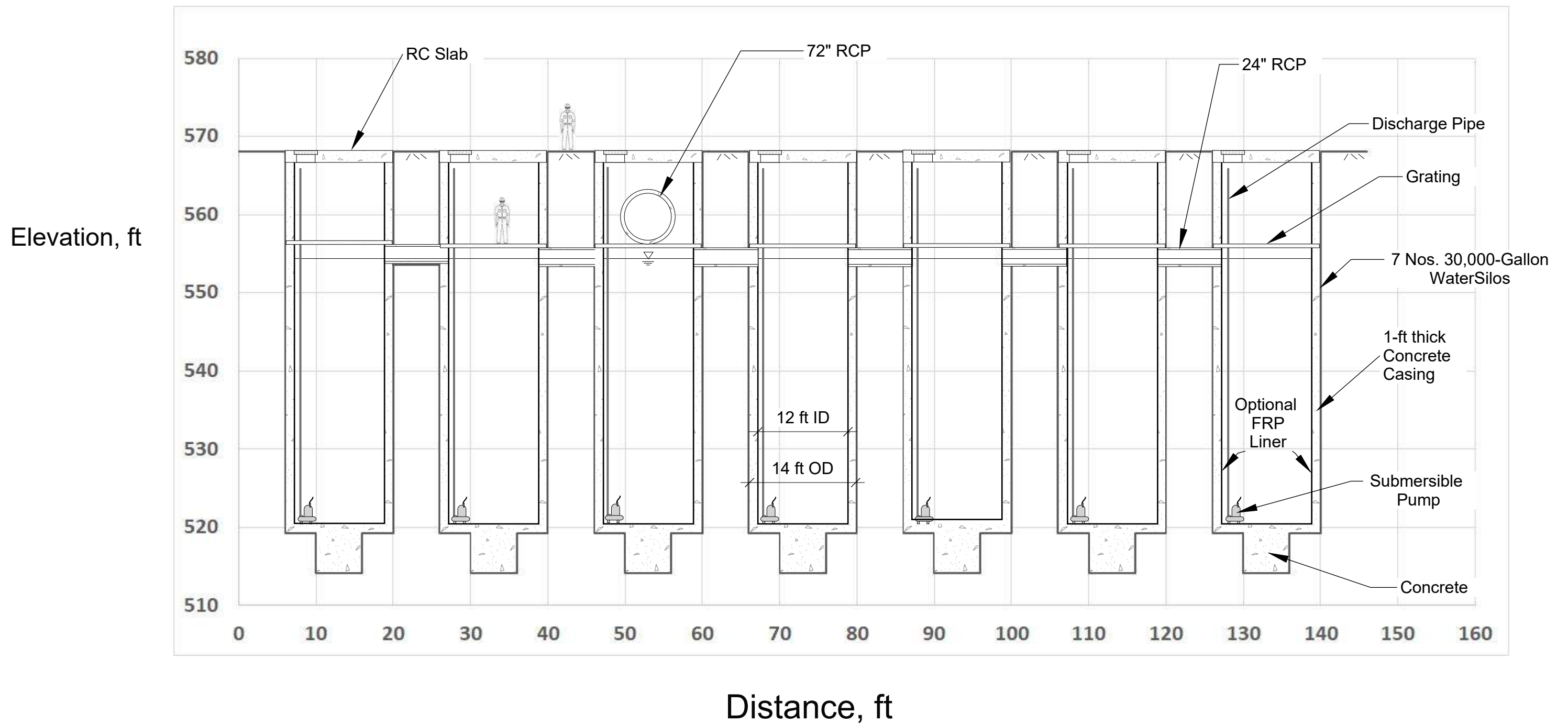

Section A-A, Sheet A1



S. Pasadena Van Horne Ave Pocket Park  
Stormwater Capture Project

MM/DD/YY	REMARKS
1	...
2	...
3	...
4	...
5	...

03

A



VESSEL CONTENT:	STORMWATER
VESSEL MATERIAL:	FIBER REINFORCED PLASTIC
STRUCTURE TYPE:	FILAMENT WIND/CHOP
STRUCTURE RESIN:	GP
CATALYST SYSTEM:	MEKP
DESIGN CODE:	ASTM-D-3299, ASTM-D-3753
DESIGN PRESSURE:	ATMOSPHERIC
DESIGN TEMPERATURE:	AMBIENT
SPECIFIC GRAVITY:	1
VISUAL DEFECTS:	ASTM-D-2563
BARCOL HARDNESS:	ASTM-D-2583
BURN TEST:	ASTM-D-2584
LINER VEIL:	C-VEIL
LINER RESIN:	GP
MIN. LINER THICKNESS:	120 MIL
LIFTING LUG MATERIAL:	STEEL
EXTERNAL SURFACE COLOR:	NATURAL (WHITE)
SEISMIC LOADING:	NONE
WIND LOADING:	NONE



Optional WaterSilo Liner Specifications



S. Pasadena Van Horne Ave Pocket Park  
Stormwater Capture Project

	MM/DD/YY	REMARKS
1	___/___/___	...
2	___/___/___	...
3	___/___/___	...
4	___/___/___	...
5	___/___/___	...





Sub Basin		Wooded Area - ac (100% Pervious)	Low D. SF A, ac (% Imp. = 21%)		Total Imp. A, ac	Total Pervious A, ac	% Imp
ID	DA, ac		Total	Pervious			
810116	34.89	9.1	25.8	20.3	5.4	29.5	15.5%
810114	20.66	11.4	9.3	7.3	1.9	18.7	9.4%
810113	36.56	19.8	16.8	13.3	3.5	33.0	9.6%
810106	45.22	10.7	34.5	27.3	7.3	38.0	16.0%
810112	12.13	1.7	10.5	8.3	2.2	9.9	18.1%
810102	23.01	5.5	17.5	13.8	3.7	19.3	16.0%
810111	46.11	13.8	32.3	25.5	6.8	39.3	14.7%
810101	40.76	7.2	33.6	26.5	7.0	33.7	17.3%
<b>Total</b>	<b>259.3</b>	<b>79.2</b>	<b>180.2</b>	<b>142.3</b>	<b>37.8</b>	<b>221.5</b>	<b>14.6%</b>

Hydrologic Soli Group	002, 013
Elev. Drop, ft	272
Longest Flow Path, ft	5,292
Drop, v ft/h ft	0.0514

85th P. Rain, in	1.04
85th P. Peak, cfs	6.1
Vm, cu-ft	210,600
Vm, ac-ft	4.8347

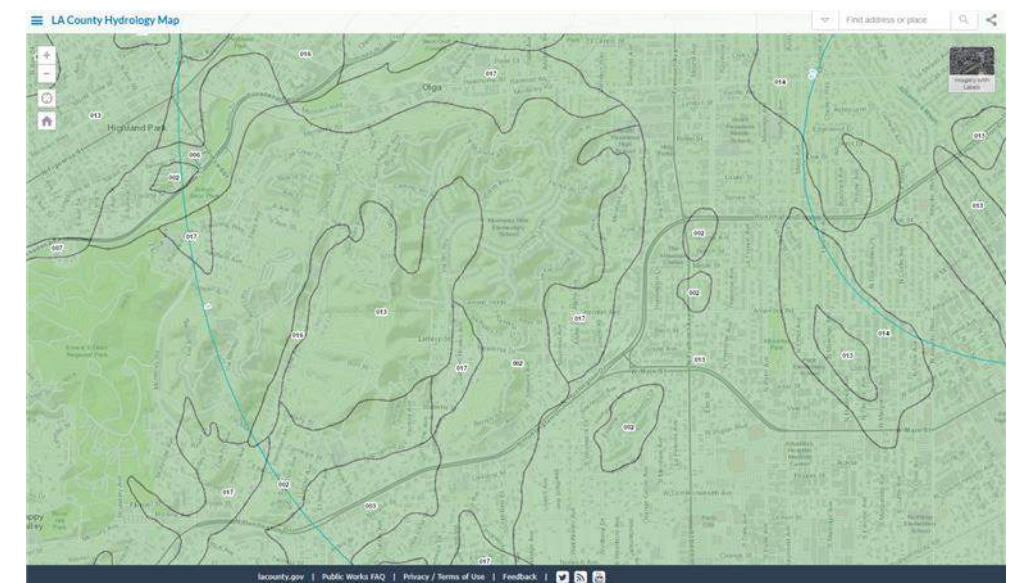
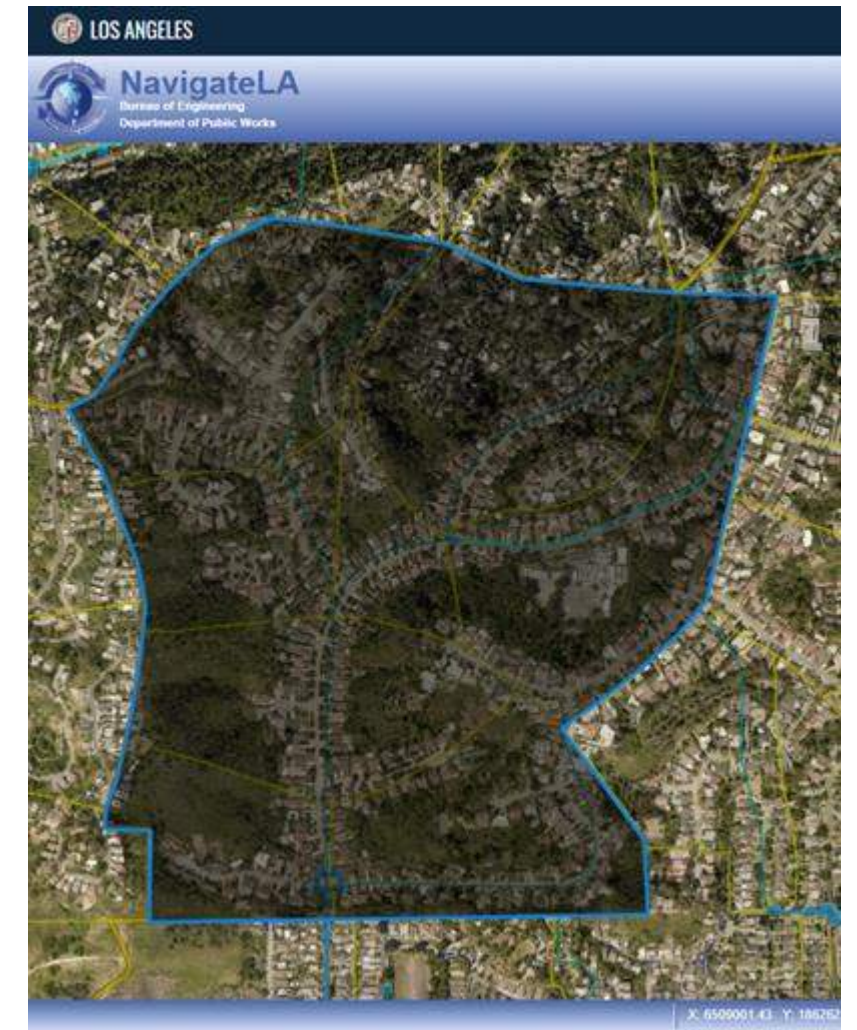
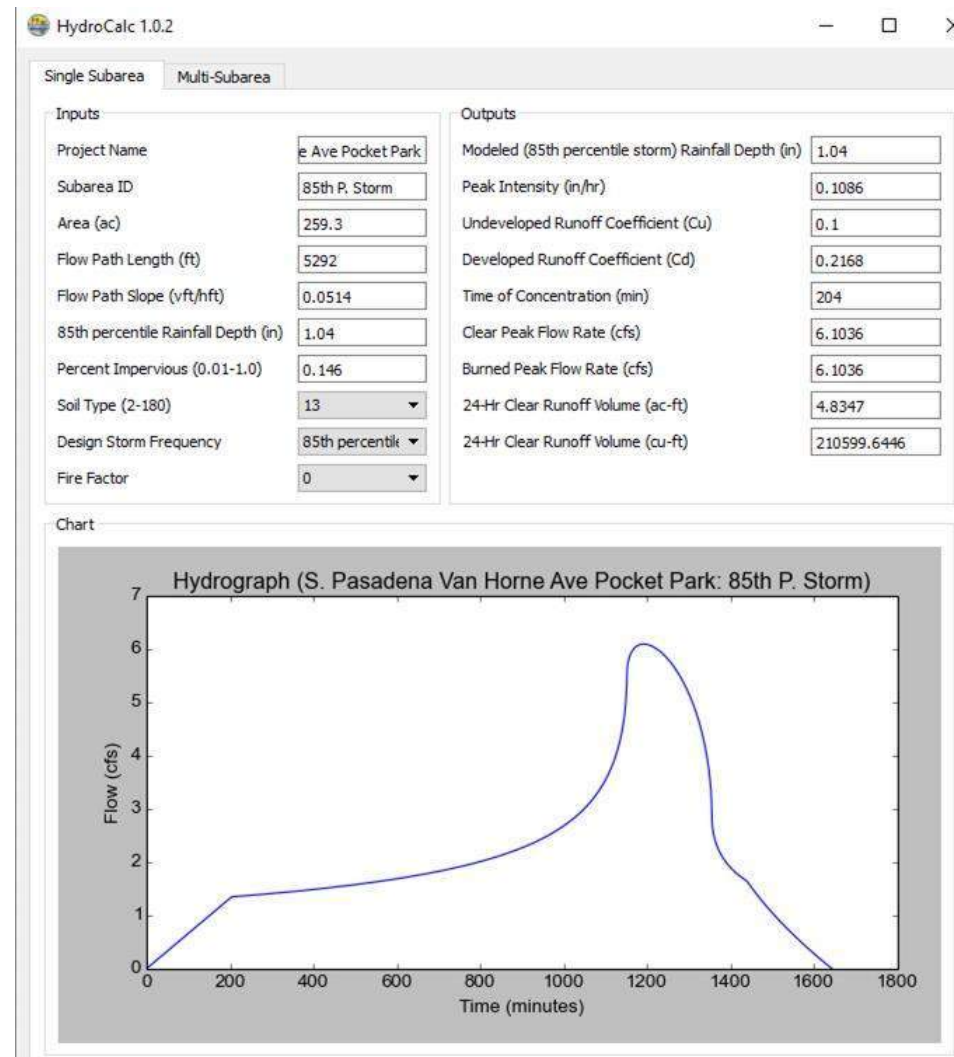

Hydrology

**SEITec**

S. Pasadena Van Horne Ave Pocket Park  
Stormwater Capture Project

MM/DD/YY	REMARKS
1	...
2	...
3	...
4	...
5	...

05

A



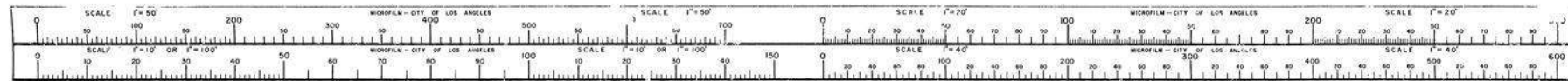

D-17599

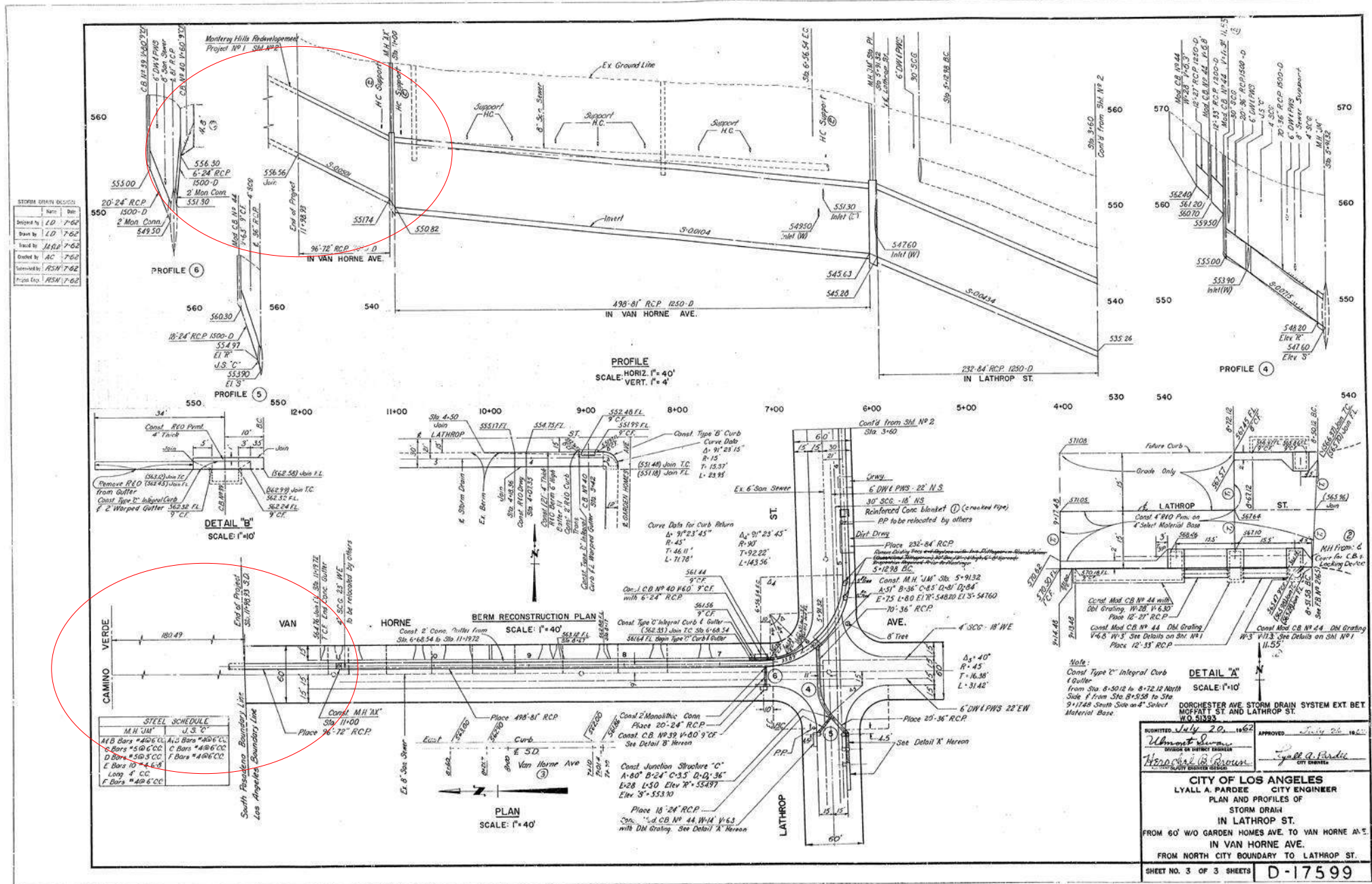

D 17599

Record Drawing

**SEITec**  
S. Pasadena Van Horne Ave Pocket Park  
Stormwater Capture Project

MM/DD/YY	REMARKS
1	
2	
3	
4	
5	

06  
A





Camino Verde Pocket Park



Catch basin



Storm drain piping



Capture area (283.6 acres)

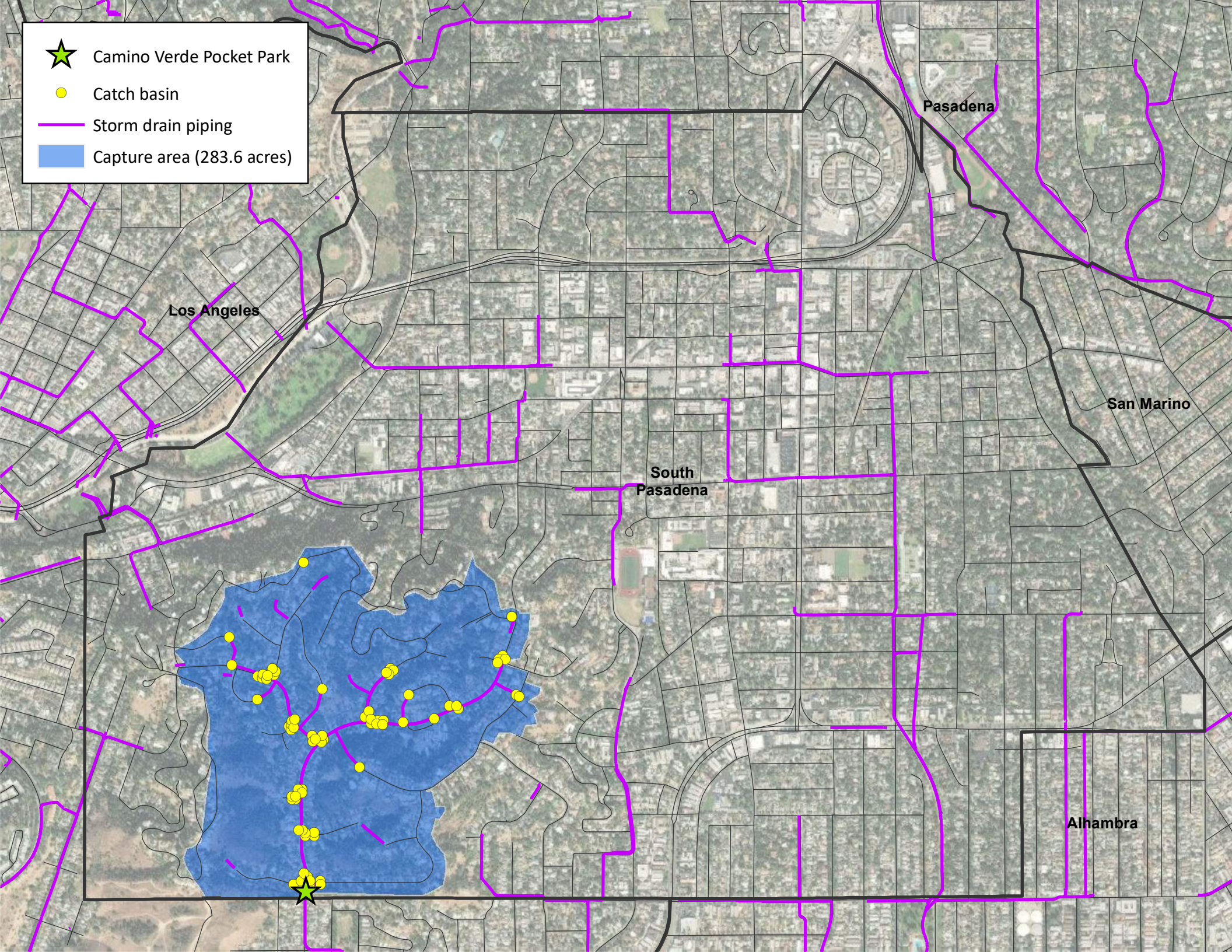

Los Angeles

Pasadena

San Marino

South  
Pasadena

Alhambra



Camino Verde Pocket Park



Sewer system (local line)



Sewer system (trunk line)



Capture area (283.6 acres)

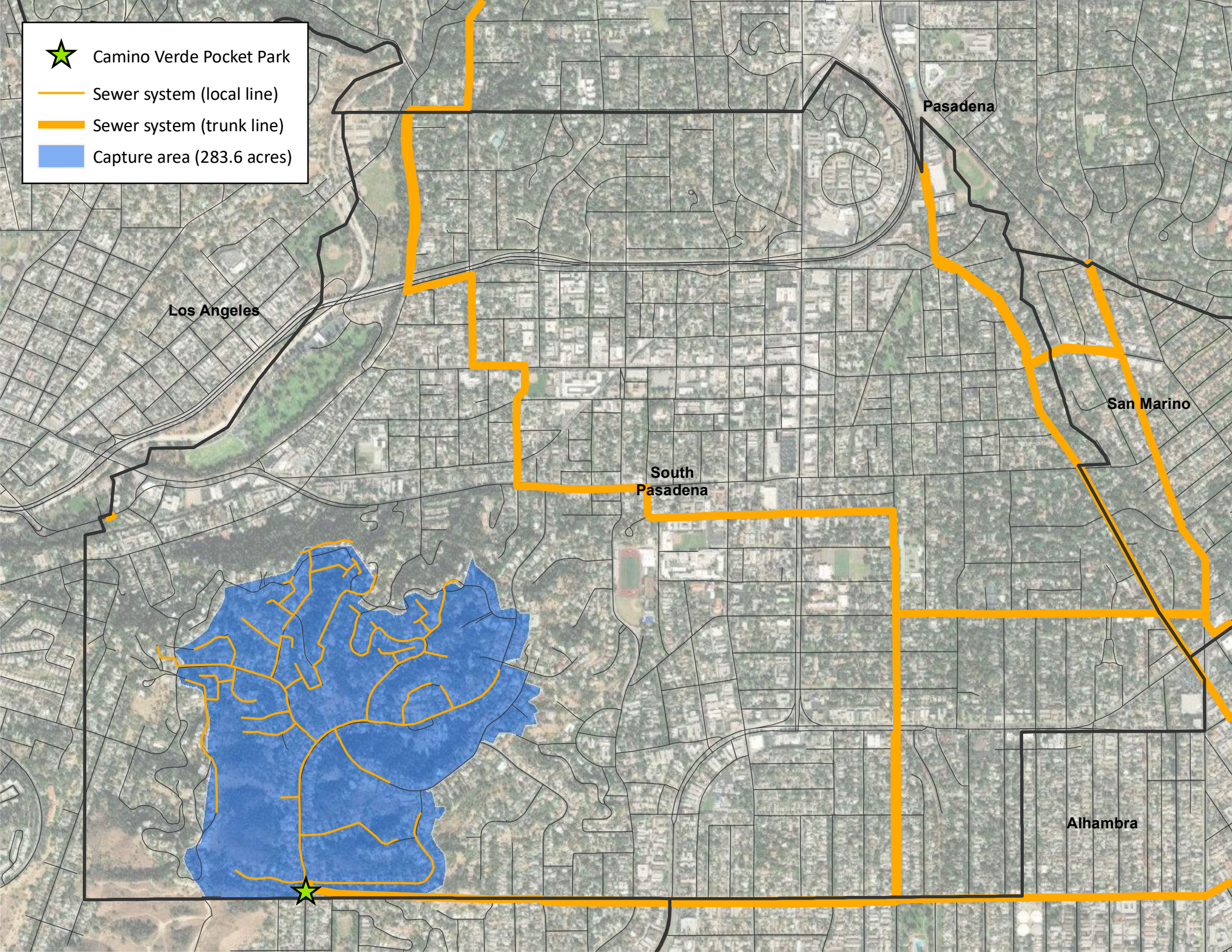

Los Angeles

Pasadena

San Marino

South  
Pasadena

Alhambra

★ Camino Verde Pocket Park

● Catch basin

— Storm drain piping



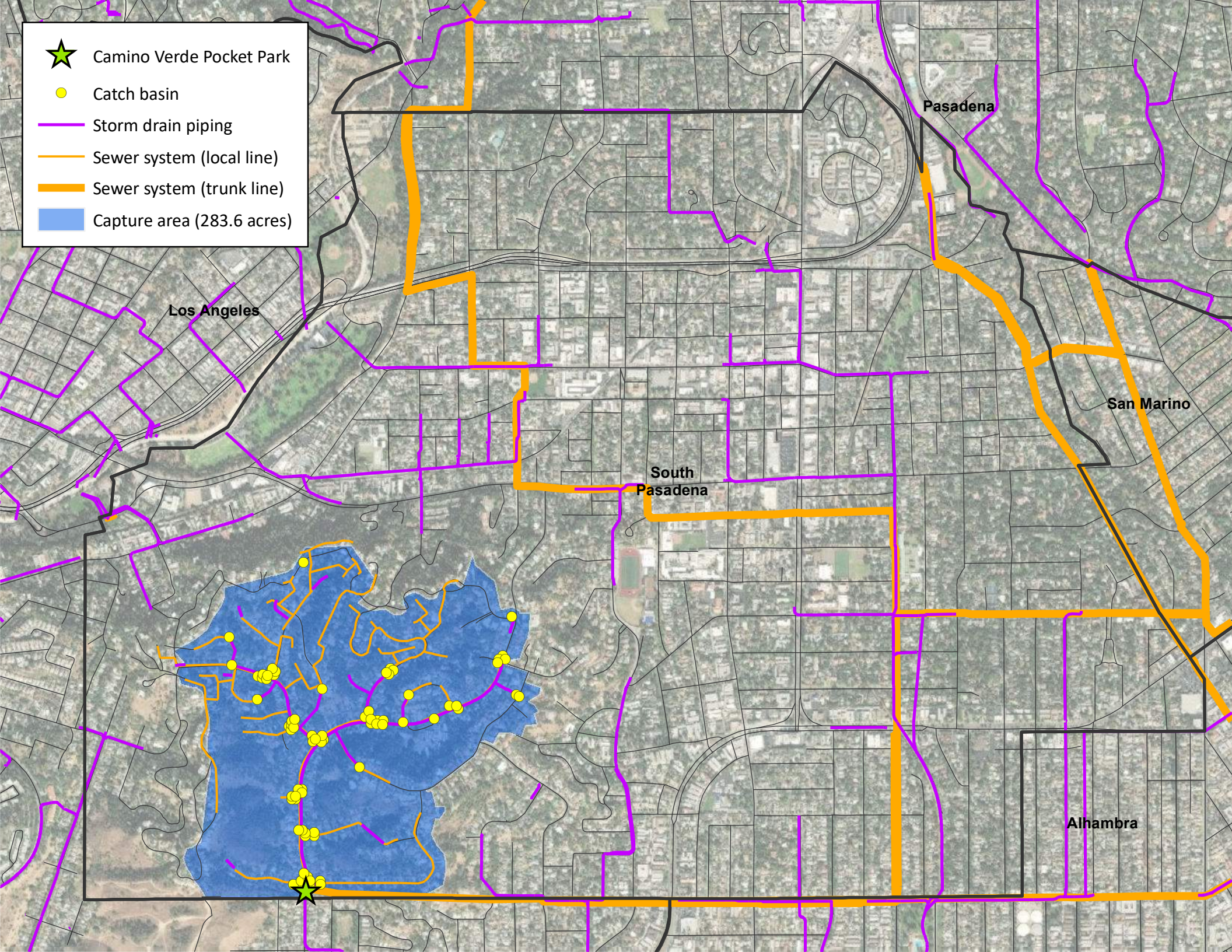

— Sewer system (local line)

— Sewer system (trunk line)

— Capture area (283.6 acres)





-  Camino Verde Pocket Park
-  Catch basin
-  Storm drain piping
-  Capture area (283.6 acres)

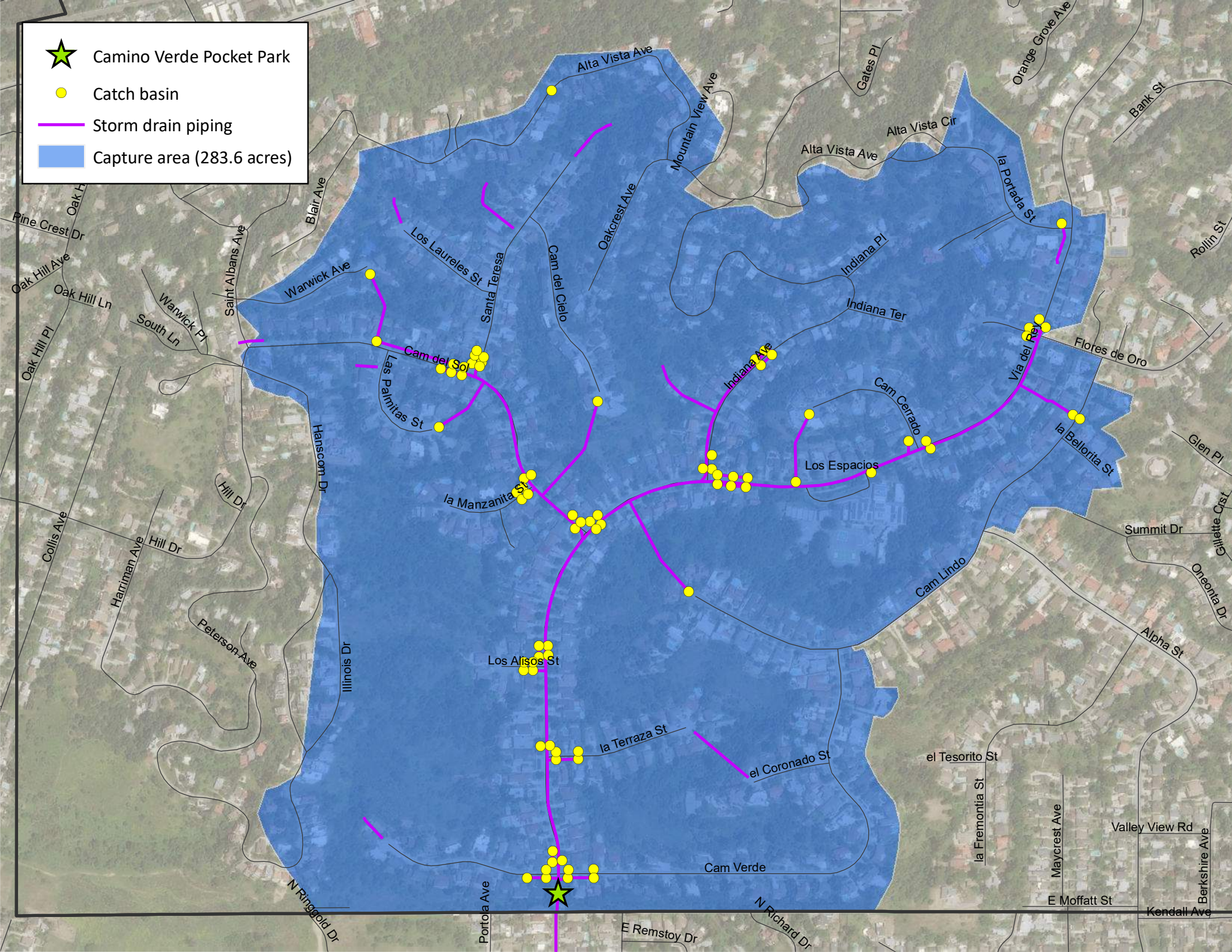





Camino Verde Pocket Park



Catch basin

Storm drain piping

Sewer system (local line)

Sewer system (trunk line)

Capture area (283.6 acres)

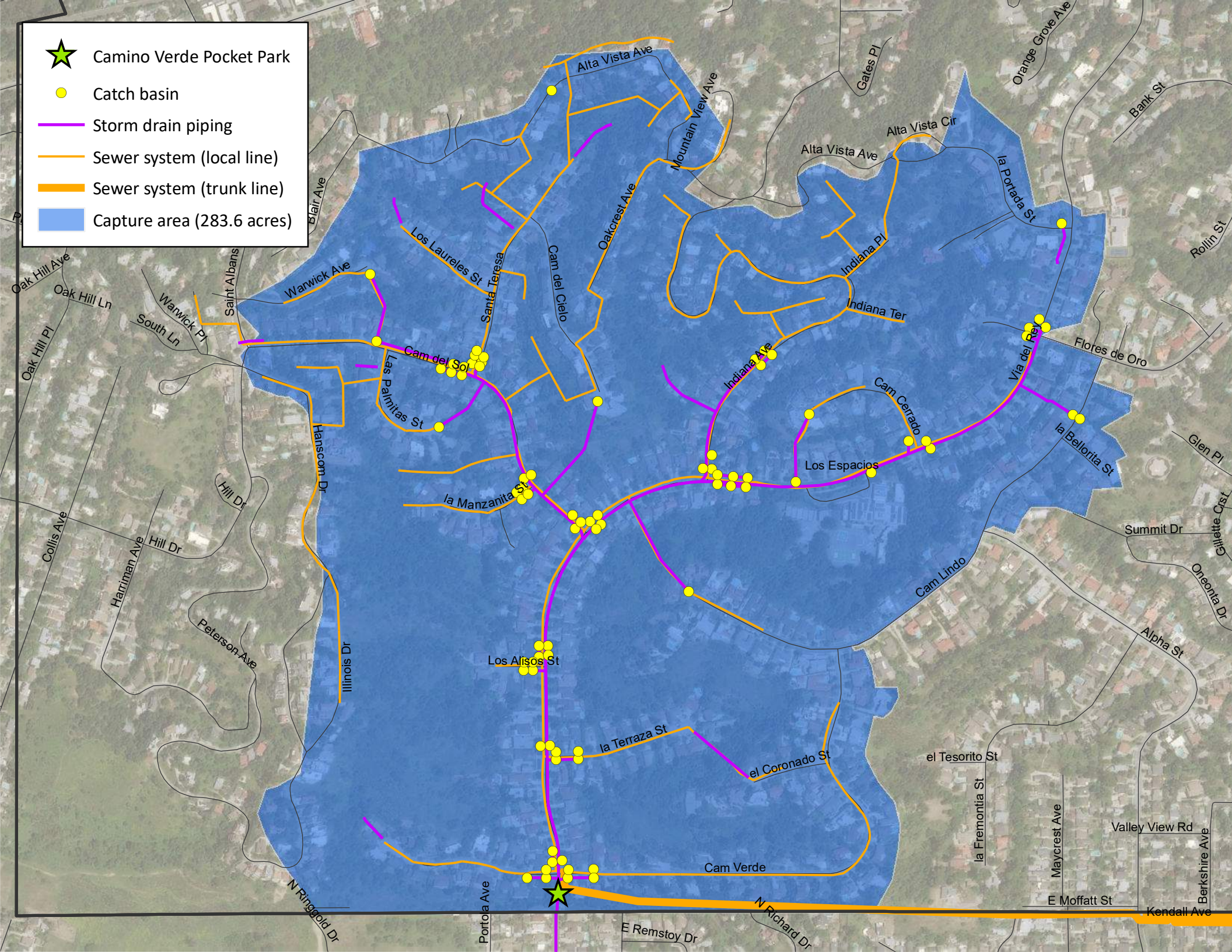

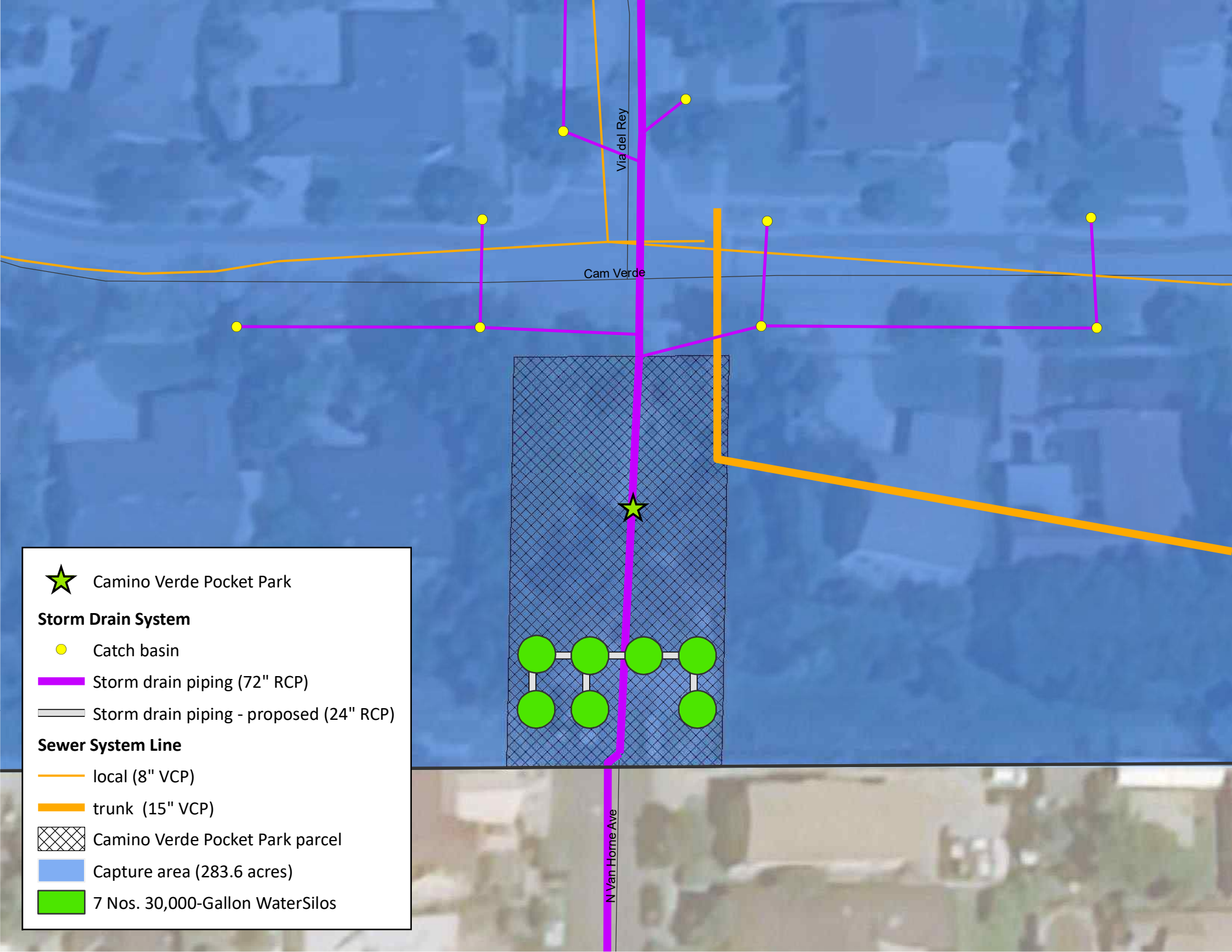

★ Camino Verde Pocket Park

**Storm Drain System**

● Catch basin

— Storm drain piping (72" RCP)

— Storm drain piping - proposed (24" RCP)

**Sewer System Line**

— local (8" VCP)

— trunk (15" VCP)

▨ Camino Verde Pocket Park parcel

■ Capture area (283.6 acres)

■ 7 Nos. 30,000-Gallon WaterSilos

Via del Rey

Cam Verde

N Van Home Ave













---

## **ATTACHMENTS FOR SECTION 3:**

### **Water Quality & Water Supply**

---

-  Camino Verde Pocket Park
-  Submitted Infrastructure Projects (FY20-21)
-  Submitted Infrastructure Projects (FY 21-22)
-  Submitted Technical Resources Projects (FY20-21)
-  Submitted Technical Resources Projects (FY 21-22)
-  Los Angeles River
-  Other open channels
-  Storm drain piping
-  ULAR EWMP
-  Watershed Boundary (LA River Reach 2)
-  Watershed Boundary

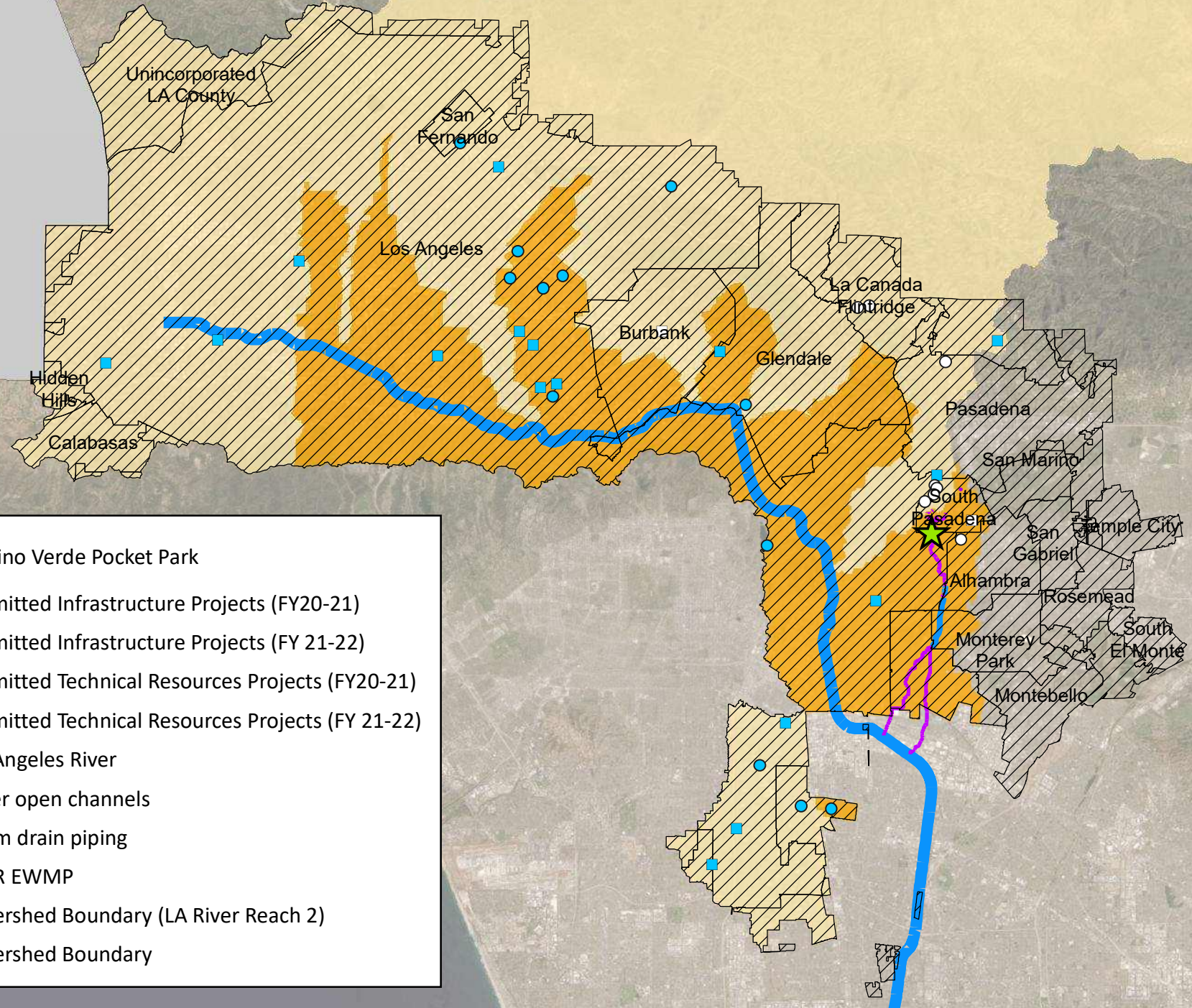



---

## **ATTACHMENTS FOR SECTION 4:**

**Community**

---







 **carollo**<sup>®</sup>